

# RADIO & TELEVISION NEWS

MAY  
1951  
35¢  
In Canada 40¢

ANC



SHOOTING A CLOSE-UP  
AT THE CBS VAUGHN MONROE SHOW

PAGE 39

THE QUALITY OF RCA TUBES IS UNQUESTIONED



# *Profit Twice...*

**with RCA picture tubes**



**PROFIT ONCE**—The largest and most profitable replacement business in television picture tubes comes from the types used in most television receivers . . . the fast-moving RCA types. That's true today . . . and it will be true tomorrow. Because they are high-volume types, RCA picture tubes simplify your inventory and stocking problems.

**PROFIT TWICE**—In addition, when you sell RCA picture tubes, you gain from customer confidence in the RCA brand . . . solidly established by the proved performance of RCA picture tubes in millions of television receivers. Their quality and dependability mean fewer service failures and fewer costly call-backs.

*Keep informed...stay in touch with your RCA Tube Distributor*



**RADIO CORPORATION of AMERICA**  
ELECTRON TUBES HARRISON, N. J.

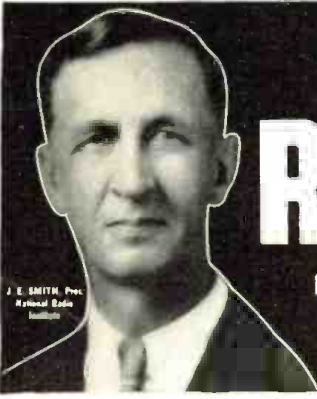

# BE A SUCCESS AS A RADIO-TELEVISION TECHNICIAN

**2 FREE BOOKS SHOW HOW MAIL COUPON**

**America's Fast Growing Industry Offers You**

**VETERANS**  
Get this training under G.I. Bill  
**MAIL COUPON!**

**I TRAINED THESE MEN**

**Chief Engineer, Police Radio**  
"Soon after finishing the N.R.I. course worked for servicing shop. Now I am Chief Engineer of WCUM Police Radio Installations. S.W. DINWIDDIE, Jacksonville, Ill.

**Shop Specialist in Television**  
"Have my own shop. Am authorized serviceman for 5 large manufacturers and do servicing for 7 dealers. N.R.I. has enabled me to build an enviable reputation in Television. P. MILLER, Maumee, O.

**Over 100 Month Spare Time**  
"When I enrolled, had no idea it would be so easy to learn. Have equipped my shop out of spare time earnings. I am clearing about \$40 to \$60 a month. Full credit to N.R.I. — J. D. KNIGHT, Denison, Texas.

**WBI Graduate Doubles Salary**  
"Am with Station WKBO as transmitter operator. Have more than doubled salary since starting in Radio. Future looks bright. N. R. I. has been constant help to me. — A. HERR, New Cumberland Pa.

**100 Week in Spare Time**  
"Before finishing your course, I earned as much as \$10 a week in Radio servicing, at home in my spare time. I recommend N.R.I. to everyone who shows interest in Radio. — S. J. PETRIFF, Nissim, Pa.

**Years of Success with Shop**  
"I operate my own shop and have over 500 customers. My profits average about \$120 a month. Have had years of successful experience and I still praise N.R.I. training. — J. H. ANDERSON, Atlanta, Ga.

**Gets Job Through N.R.I.**  
"My first job was operator with KDLR, obtained for me by your Graduate Service Dept. I am now Chief Engineer of Police Radio Station "QOX." T. S. NORTON, Hamilton, Ohio.

**Regret Not Cavalier Before**  
"Am proud of my diploma. I cannot say enough for the N.R.I. course. Regret I didn't take it years ago when I used to see your ads. Now I have a spare time shop. — FRANK S. TUCKER, Hilton Village, Va.

**1. EXTRA MONEY IN SPARE TIME**

Many students make \$5, \$10 a week extra fixing neighbors' Radios in spare time while learning. The day you enroll I start sending you SPECIAL BOOKLETS to show you how to do this. Tester you build with parts I send helps you service sets. All equipment is yours to keep.

**2. GOOD PAY JOB**

Your next step is a good job installing and servicing Radio-Television sets or becoming boss of your own Radio-Television sales and service shop or getting a good job in a Broadcasting Station. Today there are over 90,000,000 home and auto Radios. 3100 Broadcasting Stations are on the air. Aviation and Police Radio, Micro-Wave Relay, Two-Way Radio are all expanding, making more and better opportunities for servicing and communication technicians and FCC licensed operators.

**3. BRIGHT FUTURE**

And think of the opportunities in Television! In 1950 over 5,000,000 Television sets were sold. By 1954 authorities estimate 25,000,000 Television sets will be in use. Over 100 Television Stations are now operating, with experts predicting 1,000. Now is the time to get in line for success and a bright future in America's fast-growing industry. Be a Radio-Television Technician. Mail coupon for Lesson and Book—FREE.



**I Will Train You at Home**  
Read How You Practice Servicing or Communications with Many Kits of Parts You Get!

**YOU BUILD** this modern Radio (above) as part of my Servicing Course. Build this complete, powerful Radio Receiver that brings in local and distant stations. N.R.I. gives you ALL the Radio parts... speakers, tubes, chassis, transformer, sockets, loop antenna. EVERYTHING you need. You use material to get practical Radio experience. Make EXTRA money fixing neighbors' Radios in spare time while training.

**YOU MEASURE** current, voltage (AC, DC and RF), resistance and impedance in circuits with Electronic Multi-meter (above right) you build as part of my Servicing or Communications Course.

**YOU BUILD** this Transmitter (right). As part of my Communications Course, I SEND YOU parts to build this low-power broadcasting transmitter. You learn how to put a station "on the air," perform procedures demanded of Broadcast Station operators, make many practical tests.

**YOU BUILD** this Wavemeter (below) in my Communications Course with parts I send you. Use it to determine frequency of operation and make other tests on transmitter currents. You conduct many interesting experiments.

**Now! Advanced Television Practice**  
New, special TV kits furnished to build high-definition SCOPE... RF OSCILLATOR with flyback power supply... complete TV set... many other units. You use pulse, trapezoidal, saw-tooth wave forms. Get valuable PRACTICAL EXPERIENCE locating and correcting TV troubles. Mail coupon for facts, pictures and price list.

Keep your job while training at home. Hundreds I've trained are successful RADIO-TELEVISION TECHNICIANS. Most had no previous experience; many no more than grammar school education. Learn Radio-Television principles from illustrated lessons. Get PRACTICAL EXPERIENCE—build valuable Electronic Multi-meter for conducting tests; also practice servicing Radios or operating Transmitters—experiment with circuits common to Radio and Television. At left is just part of the equipment my students build with many kits of parts I furnish. All equipment is yours to keep. Many students make \$5, \$10 a week extra fixing neighbors' Radios in spare time.

**Mail Coupon For 2 Books FREE**  
Act Now! Send for my FREE DOUBLE OFFER. Coupon entitles you to actual lesson on Servicing; shows how you learn Radio-Television at home. You'll also receive my 64-page book, "How to Be a Success in Radio-Television." You'll read what my graduates are doing, earning; see photos of equipment you practice with at home. Send coupon in envelope or paste on postal. J. E. SMITH, Pres., Dept. 1EE, National Radio Institute, Washington 9, D. C. Our 38th year.

**Good for Both—FREE**

Mr. J. E. SMITH, President, Dept. 1EE  
National Radio Institute, Washington 9, D. C.  
Mail me Sample Lesson and 64-page Book about How to Win Success in Radio-Television. Both FREE. (No salesman will call. Please write plainly.)

Name \_\_\_\_\_ Age \_\_\_\_\_

Address \_\_\_\_\_

City \_\_\_\_\_ Zone \_\_\_\_\_ State \_\_\_\_\_

Check if Veteran  Approved Under G. I. Bill

**The AEC's of SERVICING**  
**How to Be a Success in RADIO-TELEVISION**

Editor

**OLIVER READ, D.Sc., D.Litt., W9ETI**

Managing Editor

**WM. A. STOCKLIN, B.S.**

Technical Editor

**H. S. RENNE, M.S.**

Associate Editor

**RAY FRANK, W9JU**

Eastern Editor

**HAROLD BECKER**

Television Consultant

**MILTON S. KIVER**

Short-Wave Editor

**KENNETH R. BOORD**

Editorial Assistants

**I. M. CARROLL**  
**E. V. HITZEL**  
**P. B. HOEFER**

Staff Artist

**R. S. KUPJACK**

Chief Draftsman

**B. L. NEWMAN, W9ROB**

Associate Advertising Director

**M. J. CULLIGAN**

Advertising Manager

**L. L. OSTEN**

Midwest Adv. Manager

**JOHN A. RONAN, JR.**

Art Director

**HERMAN R. BOLLIN**

# RADIO & TELEVISION NEWS

Reg. U.S. Pat. Off.

Radio News Trademark Reg. U. S. Pat. Office • Television News Trademark Reg. U.S. Pat. Office.

*First in*  
**radio-television-electronics**  
Average Paid Circulation over 200,000

## CONTENTS

## MAY, 1951

Naval Reserve Offers New Electronic Training Opportunities.....	35
.....Commander E. L. Battey	
Shooting a Close-up.....	39
.....William L. Stuart	
Converting the G-E Model 811.....	40
.....Roland Kempton	
A Civilian Defense Station.....	42
.....Frank Heubner	
Quality Amplifier for TV Sound.....	44
.....Lawrence Fleming	
Emergency Test Instrument.....	46
.....Fred A. Orth	
How Do You Figure Your Service Charges?.....	48
.....Harold J. Ashe	
A Mobile Low-Power 10 Meter Rig.....	49
.....Hardin G. Stratman	
Resistance Welding.....	52
.....Ed Bukstein	
Cabinets for High-Quality Direct Radiator Loudspeakers.....	53
.....Harry F. Olson	
A Novel Unit for Voice Controlled Operation.....	57
.....E. A. Anderson, VE6OD	
A Small Rig with Plenty of Power.....	58
.....Leon A. Wortman, W2LJU	
Practical Sound Engineering (Part 3).....	60
.....H. M. Tremaine	
Adapt Your Amplifier for Magnetic Recording.....	64
.....Lloyd B. Hust	
Mac's Radio Service Shop.....	66
.....John T. Frye	
Square-Wave Testing Speeds TV Servicing.....	67
.....Louis E. Garner, Jr.	
Radio-TV Service Industry News.....	104



COVER PHOTO: Scene from the CBS "Vaughn Monroe TV Show". Elaborate variety shows such as this require close coordination by artists, cameramen, directors, monitors, etc. (Ektakrome by Stahman & Warnecke)

Chairman of the Board and Publisher  
**WILLIAM B. ZIFF**

President  
**B. G. DAVIS**

Secretary-Treasurer  
**ARTHUR T. PULLEN**

Vice-Presidents  
**MICHAEL H. FROELICH**  
Dir. Eastern Div.

**H. J. MORGANROTH**  
Production Director

**LYNN PHILLIPS, Jr.**  
Advertising Director

**H. G. STRONG**  
Circulation Director

**BRANCH OFFICES**  
NEW YORK (17)  
366 Madison Ave., MUrray Hill 7-8080

LOS ANGELES (14)  
815 S. Hill St., TUcker 9213  
Manager, WILLIAM L. PINNEY

### DEPARTMENTS

For the Record.....	8	What's New in Radio.....	76
Spot Radio News.....	14	Manufacturers' Literature.....	94
Within the Industry.....	26	New TV Products.....	138
Short-Wave.....	63	Technical Books.....	148
<b>MARS</b> .....	<b>164</b>		



COPYRIGHT 1951  
ZIFF-DAVIS PUBLISHING COMPANY  
185 North Wabash Ave., Chicago 1, Ill.  
VOLUME 45 • NUMBER 5



Member  
Audit Bureau of  
Circulations

RADIO & TELEVISION NEWS is published monthly by the Ziff-Davis Publishing Company at 185 N. Wabash Ave., Chicago 1, Ill. Copyright under international copyright convention. All rights reserved. Entered as second-class matter July 21, 1948, at the Post Office, Chicago, Ill., under the act of March 3, 1879. Entered as second-class matter at the Post Office Department, Ottawa, Canada. SUBSCRIPTION RATES: in U. S., Canada, Mexico, South and Central America and U. S. Possessions, \$4.00 for twelve issues; in British Empire, \$5.00; all other foreign countries, \$5.00 for twelve issues. RADIO-ELECTRONIC ENGINEERING EDITION SUBSCRIPTION RATES: in U. S., Canada, Mexico, South and Central America and U. S. Possessions, \$6.00 for twelve issues; in British Empire, \$7.00; all other foreign countries, \$7.00 for twelve issues. Subscribers should allow at least two weeks for change of address. All communications about subscriptions should be addressed to the Director of Circulation, 185 N. Wabash Ave., Chicago 1, Ill. CONTRIBUTIONS: Contributors are advised to retain a copy of their manuscripts and illustrations. Contributions must be accompanied by return postage and they will be handled with reasonable care, but this magazine assumes no responsibility for their safety. Any copy accepted is subject to whatever adaptations and revisions are necessary to meet the requirements of this publication. Payment covers all author's, contributor's and contentant's rights, title, and interest in and to the material accepted and will be made at our current rates upon acceptance. All photos and drawings will be considered as part of the material purchased.

**RADIO & TELEVISION NEWS**

**GET IT! READ IT YOURSELF!**  
**FREE Opportunity News Bulletin**  
 shows you **89 WAYS** to earn money in  
**TELEVISION**  
**RADIO, ELECTRONICS**

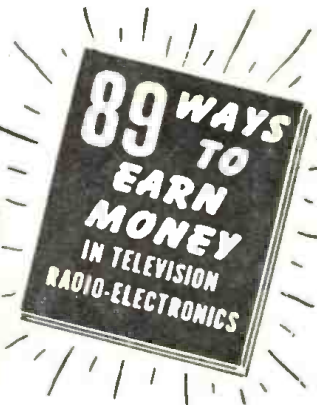

**OPTIONAL FEATURE**  
 ABOVE: Build and keep a real 16 INCH commercial TV receiver — a wonderful instructional project. Optional at slight additional cost after completing regular training.

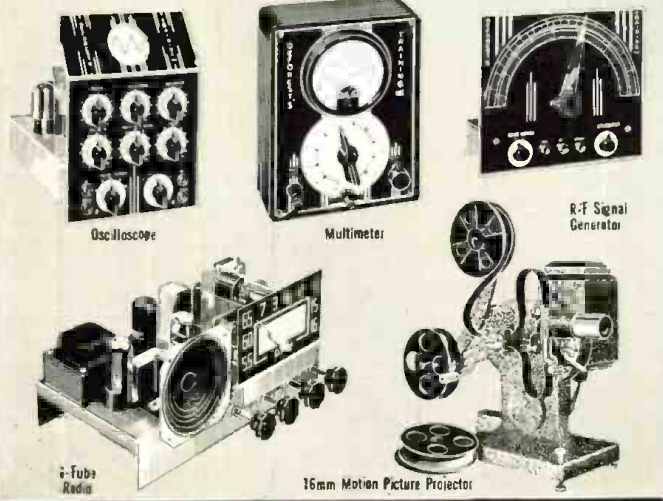

**Let us show you how readily you may prepare to enter this highly profitable field.**

Mail coupon today for YOUR FREE COPY of one of the most interesting, opportunity-packed News Bulletins we have seen. It shows you SCORES OF WAYS to make money in today's amazing, billion dollar field of Television, Radio, Electronics.

**NOW—GET THE ANSWERS!**

See HOW you can get the start you need toward a real job or your own profitable business . . . HOW you may get into work that pays real money, that's so interesting . . . HOW to build toward a grand future in one of America's most rapidly growing, promising, newer fields of opportunity.

**NO PREVIOUS EXPERIENCE OR KNOWLEDGE NEEDED:** You'll see WHY DeForest's Training, Inc. offers one of the most complete combinations of practical, home training advantages available today . . . HOW you can get and keep the same type of basic electronic equipment used in our Chicago training laboratories, one of the nation's finest . . . HOW you set up your own HOME LABORATORY and work over 300 experiments — including building and keeping the commercial-type test equipment shown at lower left.

**HOME MOVIES:** You'll even see HOW you can get the wonderful advantages of "learn-by-seeing" movies on the wall of your own room. See hidden actions that can help you tremendously to understand and remember certain points.

**EMPLOYMENT SERVICE:** And by all means, see HOW you can get training that also combines an Employment Service for that all-important starting help after you complete the program.

**MILITARY SERVICE!**  
 If subject to military service, the information we have for you should prove doubly interesting. Mail coupon today.

**MODERN LABORATORIES:** If preferred, you can get all your preparation in our new Chicago training laboratories—one of the finest of its kind.

**Here is YOUR big chance!**

DeFOREST'S TRAINING, INC., Dept. RN-5-H  
 2533 N. Ashland Ave., Chicago 14, Ill.

Without obligation, I would like that new Opportunity News Bulletin showing 89 ways to earn money in Television-Radio-Electronics . . . and how I may prepare to get started in this thrilling field.

Name..... Age.....  
 Street..... Apt.....  
 City..... Zone..... State.....

**MAIL COUPON TODAY!**

**DeFOREST'S TRAINING, INC.**  
 CHICAGO 14, ILLINOIS  
 A De VRY INSTITUTION

# NEW INDICATOR ION TRAP

*A  
Rauland  
"Exclusive"*



## Speeds Service — Builds Profits

Rauland's new Indicator Ion Trap is winning the cheers of more service men and dealers every day — because of the time and trouble it saves in Ion Trap Magnet adjustment, and because it eliminates mirrors and guesswork.

Now it's a matter of seconds to adjust the ion trap magnet with absolute precision. The service man simply moves the magnet until the signal glow is reduced to minimum.

This important new Rauland development is incorporated in all Rauland tubes produced today — as a feature of Rauland's new Tilted Offset Gun. This gun offers the additional advantages of giving only a single Ion Trap Magnet and of maximum sharpness of focus.

Only Rauland offers this advanced feature — one of half a dozen post-war developments from Rauland.

For further information, write to ...

### **RAULAND**

The first to introduce commercially these popular features:

Tilted Offset Gun

Indicator Ion Trap

Luxide (Black) Screen

Reflection-Proof Screen

Aluminized Tube

## **THE RAULAND CORPORATION**



*Perfection Through Research*

4245 N. KNOX AVENUE • CHICAGO 41, ILLINOIS



**YOUR OPPORTUNITY IS HERE NOW! LEARN**

# TELEVISION

**RIGHT AT HOME!**

By the new method of

## TRANSPONDENCE

training on film and tape recordings

Now the De Forest-Sanabria Corporation—a division of the world's largest television training school—brings class-room instruction to you right in your own home! You actually hear your instructor's recorded voice. At the same time you watch "blackboard" size projected pictures, diagrams and illustrations. It's the quick, easy way to equip yourself for the big earnings in television—today!

**LOOK . . . You get the tape recorder and projector right at the start of your course!**



### HEAR your instructor

It's even better than the classroom, because you can repeat the instructor's lectures until they're thoroughly understood.

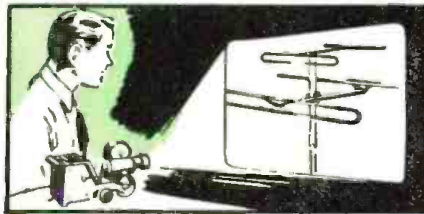

### SEE 2000 illustrations

You learn quicker when you see diagrams and illustrations in black-board size.

APPROVED FOR VOCATIONAL REHABILITATION

You get the famous "TRANSPONDER" precision built, high fidelity tape recording machine with your very first lesson—and a powerful projector with which you can view diagrams and illustrations enlarged to a size that makes them easy to see and understand.

**APPROVED FOR VETERANS UNDER G.I. BILL**

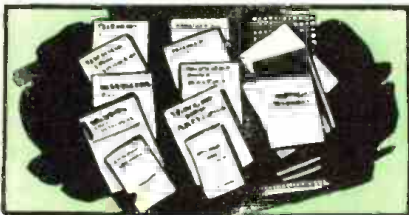

### READ from reference library

You receive complete books, pamphlets and manuals to supplement your instructor's lessons.



### ASK your questions on tape

Tell your instructor about anything that puzzles you and get his answers back pronto.



## BE A SUCCESS . . . ACT NOW!

Millions of television set owners are demanding qualified television technicians to service their sets. There is a tremendous shortage of such qualified men today and will be for many years to come. Get in on the ground floor of this booming industry and be prepared to accept a steady, big pay job for life. We can qualify you quickly, easily, surely—and help get you a job when you complete your course. Send for illustrated booklet that gives the complete details.

## MAIL COUPON TODAY!

De Forest-Sanabria Corporation **FREE BOOK**  
Dept. RN-5  
5050 Broadway, Chicago 40, Ill. **TELLS HOW**

Dear Sirs:

Please send me copy of your free illustrated booklet which describes the new TRANSPONDENCE method of learning television at home under the direction of Dr. Lee de Forest and U. A. Sanabria.

NAME \_\_\_\_\_ AGE \_\_\_\_\_

ADDRESS \_\_\_\_\_

CITY \_\_\_\_\_ STATE \_\_\_\_\_

Check here  IF VETERAN  NON-VETERAN

**The De Forest-Sanabria Corp.**

An affiliate of American Television, Inc.

5050 North Broadway, Chicago 40, Illinois

**NO SHADOWS**

with new  
**DUAL SPOTLIGHT**  
**Soldering Gun**

Pull the trigger of your new light-duty Weller Soldering Gun, and instantly twin spotlights focus on the job—banish every shadow. Five seconds later the tip is at soldering heat! No waiting. No wasted current. This streamlined 135-watt—newest of the famous Weller line—is fast! Built compactly for working in crowded chassis, too. And the time and power you save pays for your Weller Gun in a few months.

**New**  
**135-Watt**  
**Weller**  
**Soldering**  
**Gun**

**Specially Designed**  
**for TV and Radio Work**

- **DUAL SOLDERLITE**—Two prefocused spotlights completely eliminate shadows.
- **OVER/UNDER DESIGN**—Tube construction braces tip and improves visibility.
- **5-SECOND HEATING**—Pull the trigger and you solder!
- **LONGER REACH**—Slides easily into deep chassis; reaches the tightest corners.
- **GREATER CAPACITY**—Smaller, lighter, with greater soldering capacity.
- **TRIGGER-SWITCH CONTROL**—Adjusts heat to the job. No need to unplug gun between jobs.
- **DUAL HEAT**—Single heat 100 watts; dual heat 100/135 watts; 120 volts; 60 cycles. Handles all light-duty soldering.

See new Models WS-100 and WD-135 at your distributor, or write for bulletin direct.

• **SOLDERING GUIDE**—Get your new copy of "Soldering Tips"—revised, up-to-date, fully illustrated 20-page booklet of practical soldering suggestions. Price 10¢ at your distributor, or order direct.

**WELLER**  
**ELECTRIC CORP.**

810 Packer Street, Easton, Pa.



*For the* **RECORD.**

BY THE EDITOR

## RADIO & TELEVISION'S MORALE VALUE

IT IS estimated that over 30,000,000 people, through the medium of television, and countless millions of radio listeners, either saw or heard our Government in action during the Senate crime hearings. The reactions to these broadcasts and telecasts clearly indicate that we, in this country, are the best informed citizens in the entire world. Here in the United States we have long had the privilege of enjoying, or should we say have been blessed with, such things as "freedom of the press." We have learned to tolerate many stupid commercials as part of our radio and television programs, knowing that without them it would be impossible to enjoy such excellent program material unless such entertainment were sponsored by the "free enterprise" system of our country.

The public has had a very real opportunity to witness the tremendous educational value of television, as well as radio. Our GI's too, through the facilities of radio, are constantly in touch with home and with Federal action through the medium of the Armed Forces Radio Service.

We had the opportunity, but a few weeks ago, to travel with personnel of the AFRS on assignment to Travis Air Base in California. Our mission was to take color cover shots of the remote recording crew in action, and to observe the techniques used by the AFRS in the recording of programs for subsequent dubbing, pressing, and distribution to our GI's throughout the world. But that is a story in itself and will be told in a later issue. The point we would like to stress is that the morale of the American GI, and we were able to interview many, is maintained at a high level through news from home and from "de-commercialized" entertainment broadcast through the AFRS channels comprising the largest radio network in the world. AFRS overseas outlets now total 60 standard wave broadcasting stations. In the zone of the interior, its bedside network consists of 46 carrier stations in the Army, Navy, and Air Force hospitals.

In its overseas transcription activities, AFRS writes and broadcasts about 16 hours of programs. About 40 hours of programs are taken from the major networks and de-commercialized. Approximately 60 musical numbers are recorded weekly for the basic music library and distributed to Army, Navy, and Air Force Stations. All overseas transcriptions are shipped by high priority air. At present the AFRS moves about 40,000 sixteen-inch, 33 1/3 r.p.m. vinylite transcriptions

monthly. Its short-wave operations are maintained from both Los Angeles and New York. AFRS is on the air 510 broadcast hours per month over 11 powerful transmitters on both coasts. The west coast transmissions total 1777 transmitter hours per month over seven of these transmitters and the east coast 450 hours over the other four.

We also had the opportunity of visiting the home plant of AFRS in Hollywood, which is equipped with three recording studios, a recording room or control center, a master control room for short-wave broadcasting, and 12 sound-proofed audition tanks (used for editing and de-commercializing), a modern and well-equipped maintenance shop staffed by expert audio men, a tape assembly studio, a remote recording section, and office space occupied by the technical production branch.

The majority of original recordings are made on magnetic tape, using *Ampex* and *Stancil-Hoffman* units. Each machine is checked daily for frequency response, distortion, and mechanical difficulties. The recorded tape master is later transferred to acetate by dubbing and subsequent processing and pressing.

The Remote Recording Section completes about 30 remotes a month and recordings are made under wide and varied conditions. The recording crew is called upon to "take" everything from an interview to a concert.

Under the capable direction of Col. W. M. Wright, Jr. and his staff, the facilities of AFRS have expanded into what is perhaps the largest single radio network in the world. The American GI will tell you that the AFRS has, and is, keeping him in close touch with news, sports, and other happenings back in the states.

AFRS today has, according to a State Department estimate, a worldwide listening public of over 90,000,000 persons. Although its primary function is to serve servicemen overseas, it recognizes its responsibility to give its large non-service audience an undistorted picture of America and Americans, while it attempts to make a spokesman for democratic good-will of every United States serviceman stationed abroad.

Our Industry, meeting *en masse* at its annual convention in Chicago this month, may point with pride to the educational and morale building contributions made possible by our mass production of radio and television products for the GI and the American people. . . . O.R.

RADIO & TELEVISION NEWS



**GET IT!**

**1951 ALLIED catalog**

**free!**

the only complete  
up-to-date catalog for  
Everything in Radio, Television  
and Industrial Electronics

212 value-packed pages

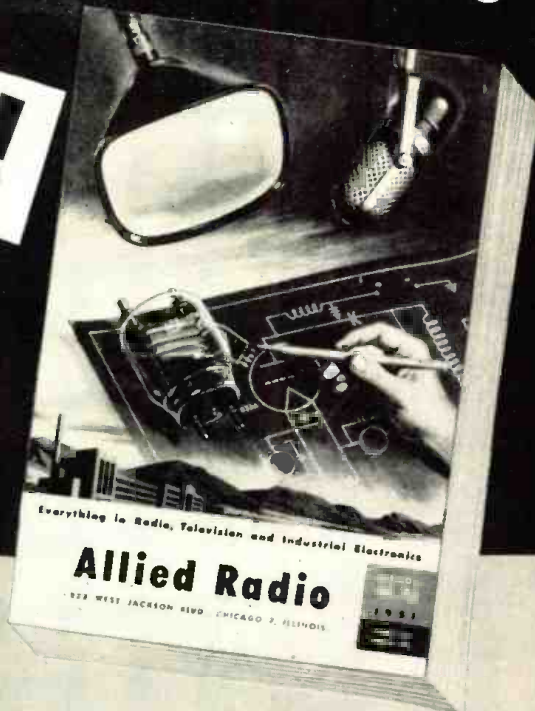

**Send for it today!**

Here's the only *complete, up-to-date* Buying Guide to TV, Radio and Industrial Electronics—packed with the world's largest selections of quality equipment at lowest, money-saving prices. See the latest in TV, AM and FM receivers; radio-phonos; new Sound Systems and P.A. equipment; High-Fidelity Custom Sound components; recorders and accessories; full selections of newest Amateur receivers and station gear; test instruments; builders' kits; huge listings of parts, tubes, tools, books—the world's *most complete stocks* of quality equipment.

ALLIED gives you *every* buying advantage; speedy delivery, expert personal help, lowest prices, assured satisfaction, liberal time payment terms. Get the latest 1951 ALLIED Catalog. Keep it handy—it will save you time and money. Send for your FREE copy!

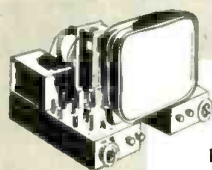

**THE WORLD'S  
LARGEST STOCKS**



Radio Parts Unlimited

Test Instruments

Television & Home Radios

P.A. and Hi-Fi Equipment

Amateur Station Gear

Supplies for Industry

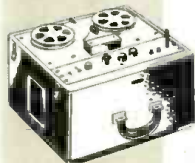

**QUICK, EXPERT SERVICE**



SEND TODAY FOR RADIO'S  
LEADING BUYING GUIDE

**ALLIED IS YOUR TELEVISION HEADQUARTERS**



To keep up with TV, depend on ALLIED! Count on us for the latest releases and largest stocks of picture tubes, component parts, antennas and accessories—plus the latest in TV tuners and kits. If it's anything in TV—depend on ALLIED!

**free**



ALLIED RADIO CORP.  
833 W. Jackson Blvd., Dept. 1-E-1  
Chicago 7, Illinois

Send FREE 212-page 1951 ALLIED Catalog No. 126

Name \_\_\_\_\_

Address \_\_\_\_\_

City \_\_\_\_\_ Zone \_\_\_\_\_ State \_\_\_\_\_

**ALLIED RADIO**

*the World's Largest Radio Supply House*

**EVERYTHING IN ELECTRONICS**



**DON'T LET HIM "PITCH" YOU**

**BLACK  
IS  
WHITE...**

**INSIST ON**

**Sheldon "Telegenic" Picture Tubes**  
*where* **BLACK IS BLACK -**  
**WHITE IS WHITE -** *and between*  
**ALL THE NATURAL**  
**INTERMEDIATE SHADING!**

This FULL RANGE of picture tones seen only on Sheldon "Telegenic" Picture Tubes, makes possible MAXIMUM CONTRAST with CLARITY . . . with NO EYE STRAIN and NO GLARE . . . whether on a Velour Black or clear face screen . . . whether viewed in daylight or under artificial light.

Superior picture quality is the reason why Sheldon Picture Tube production has been stepped up to 5,000 daily! This production increase is made possible by another recent installation of the most modern in-line exhaust unit in the industry.

**SHELDON ELECTRIC CO.**

A Division of ALLIED ELECTRIC PRODUCTS INC.  
 68-98 Coit Street, Irvington 11, N. J.

Branch Offices & Warehouses:  
 CHICAGO 7, ILL., 426 S. Clinton St. • LOS ANGELES 26, CAL., 1755 Glendale Blvd



*Manufacturers of*  
 SHELDON TELEVISION PICTURE TUBES  
 CATHODE RAY TUBES • FLUORESCENT  
 LAMP STARTERS AND LAMPHOLDERS  
 SHELDON REFLECTOR & INFRA-RED  
 LAMPS • PHOTOFLOOD & PHOTOSPOT  
 LAMPS • TAPMASTER EXTENSION CORD  
 SETS & CUBE TAPS • SPRING-ACTION  
 PLUGS • RECTIFIER BULBS

**WRITE FOR VISUAL PROOF  
 OF SHELDON'S SUPERIOR PICTURE QUALITY!  
 MAIL COUPON TODAY**

Sheldon Electric Co., 68 Coit St., Irvington 11, N. J. B

Send  Proof of Picture Quality  
 "Characteristics and Dimensions" Wall Chart  
 "Television Mis-Information"  
 "Ion Burns—How to Prevent Them" Brochure  
*(They're free — but PLEASE PRINT)*

Name: \_\_\_\_\_ Title: \_\_\_\_\_  
 Company: \_\_\_\_\_  
 Street: \_\_\_\_\_  
 City: \_\_\_\_\_ Zone: \_\_\_\_\_ State: \_\_\_\_\_

**VISIT BOOTH NO. 201, PARTS DISTRIBUTOR SHOW, STEVENS HOTEL, CHICAGO, MAY 21-23.**

© 1951—ALLIED ELECTRIC PRODUCTS INC.

**RADIO & TELEVISION NEWS**



# Learn RADIO

## TELEVISION, ELECTRONICS

by

### SHOP METHOD HOME TRAINING

Let NATIONAL SCHOOLS, of Los Angeles, a practical Technical Resident Trade School for almost 50 years, train you for today's unlimited opportunities.

You receive all parts, including tubes, for building this fine, modern Superheterodyne Receiver. This and other valuable standard equipment becomes your property.

*these two FREE books will tell you how*



WE BRING  
NATIONAL  
SCHOOLS TO YOU!

### GOOD JOBS AWAIT THE TRAINED RADIO TECHNICIAN

You are needed in the great modern Radio, Television and Electronics industry! Trained technicians are in constant and growing demand at excellent pay—in Broadcasting, Communications, Television, Radar, Research Laboratories, Home Radio Service, etc. National Schools Master Shop Method Home Study Course, with newly added lessons and equipment, can train you in your spare time, right in your own home, for these exciting opportunities. Our method has been proved by the remarkable success of National Schools-trained men all over the world.

#### You Learn by Building Equipment with Standard Radio Parts We Send You

Your National Schools Course includes not only basic theory, but practical training as well—you learn by doing. We send you complete standard equipment of professional quality for building various experimental and test units. You advance step by step until you are able to build the modern superheterodyne receiver shown above, which is yours to keep and enjoy. You perform more than 100 experiments—build many types of circuits, signal generator, low power radio transmitter, audio oscillator, and other units. The Free Books shown above tell you more about it—send for them today!



#### NOW! NEW PROFESSIONAL MULTITESTER INCLUDED

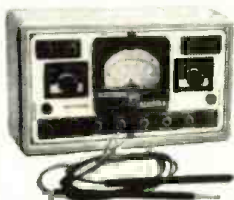

This versatile testing instrument is portable and complete with test leads. Simple to operate, accurate and dependable. You will be able to quickly locate trouble and adjust the most delicate circuits. You can use the Multitester at home or on service calls. It is designed to measure AC and DC volts, current resistance and decibels. You will be proud to own and use this valuable professional instrument.

GET THE DETAILS — SEND THE COUPON →

May, 1951

#### Lessons and Instruction Material Are Up-to-date, Practical, Interesting

National Schools Master Shop Method Home Training gives you basic and advanced instruction in all phases of Radio, Television and Electronics. Each lesson is made easy to understand by numerous illustrations and diagrams. All instruction material has been developed and tested in our own shops and laboratories, under the supervision of our own engineers and instructors. A free sample lesson is yours upon request—use the coupon below.

#### TELEVISION TRAINING

A complete series of up-to-the-minute Television lessons is an integral part of your course, covering all phases of Television repairing, servicing and construction.

Here are just a few of the interesting facts you learn with the  
**FREE SAMPLE LESSON**

1. How radio receivers operate.
2. How the antenna circuit is constructed.
3. Converting signal currents into sound.
4. How the R-F transformer handles the signal.
5. How the tuning circuit functions.
6. The Radio "bands."

**APPROVED  
FOR  
VETERANS**  
Check  
coupon below.

### NATIONAL SCHOOLS

LOS ANGELES 37, CALIFORNIA EST. 1905



#### MAIL OPPORTUNITY COUPON FOR QUICK ACTION

National Schools, Dept. 5-RN  
4000 South Figueroa Street  
Los Angeles 37, California

(Mail in envelope or  
paste on penny postcard.)

Mail me FREE the book "Your Future in Radio-Television" and the sample lesson of your course. I understand no salesman will call on me.

NAME \_\_\_\_\_ AGE \_\_\_\_\_

ADDRESS \_\_\_\_\_

CITY \_\_\_\_\_ ZONE \_\_\_\_\_ STATE \_\_\_\_\_

Check here if veteran of World War II

# STAY TUNED IN!

Always  
There's a **NEWS** Program  
from the **TELETOWER**

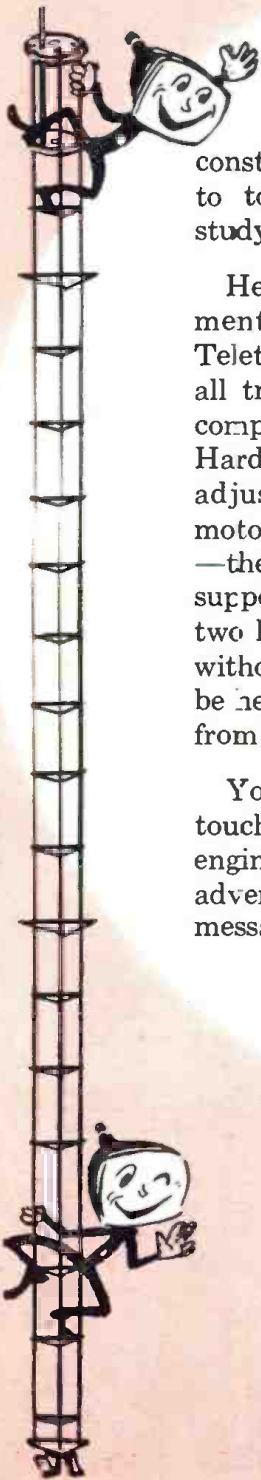

Teletower always has... does... and always will... place "high priority" upon development engineering. It was constant design study that pushed Teletower to top position in sales. *Continuing* design study will keep it "the tower in your future."

Here are just a few of Teletower's development engineering achievements: (1) The Teletower itself... today's "best seller" among all tripods—(2) The Thrifttower... the field's competitive-price leader—(3) The Tenna-Mast Hardware line of pole base mounts—(4) The adjustable roof mount—(5) The universal motor mount—(6) The built-in base—(7) And—the very newest—a "revolution" in antenna supports: the *new* baseless tower that supports two hundred and fifty pounds of stack weight without using a single strand of guy wire! You'll be hearing *plenty* more about this one soon... from Penn... from dealers... from set-owners.

You'll be robbing your future if you lose touch with today's developments in tower engineering. Watch this publication for our advertising... and watch your mail for timely messages from the Teletower.

**STAY TUNED IN...**  
TO *Teletowers!*

A FEW DEVELOPMENT  
ENGINEERING ACHIEVEMENTS  
OF JUST ONE YEAR!



*Pole Base Mount.* Durable aluminum base with adjustable socket to accommodate 1" O.D. tubing to 2" pipe. Competitively priced.

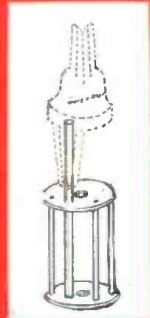

*Universal Motor Mount.* Fixed pole extending 9" beyond top of tower makes this mount easy to adapt to all antenna rotors. Centers on Alliance firm, off-center mounting for other types.

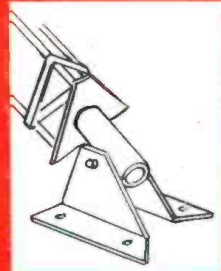

*Built-in Base.* Permits raising tower on severest slope after base is fastened to roof. Heavy plate takes tower thrust.

**PENN** Teletowers  
Thriftowers  
Tenna-Mast

**PENN BOILER AND BURNER MFG. CORP.**  
LANCASTER, PA.



# TONE ARMS— STYLI



Type UPX-006



Type RPX-041

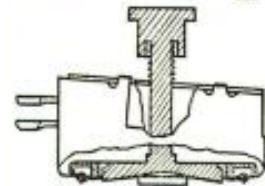

Type RPX-050 (Triple Play)

**...still available  
...still tops**

### HERE'S PLUS BUSINESS!

Use G-E phono Preamplifiers to sell *modernization* to your customers. Self-contained for easy installation, these units are ready to operate when connected to a power source. They provide sufficient amplification to enable the Variable Reluctance Cartridge to be used with any standard phonograph.

PRODUCT shortages? Sure. But there's *never* a letdown in the *quality* of G-E phono-accessories . . . and the items shown above are still available to manufacturers, jobbers, dealers and servicemen.

The G-E tone arm is built to accommodate the famous G-E Triple Play Cartridge (also in stock). It's equipped with ball bearings for smooth lateral movement . . . special light weight alloy keeps the arm mass to a minimum . . . stylus pressure is *constant at 6-8 grams for all three speeds* to reduce record wear. Plainly marked selector knob projects through the top of the arm—a single twist

places either stylus in playing position.

General Electric's high compliance Baton Stylus with diamond or sapphire tip is unsurpassed in its field. Stock it in quantity—give your customers listening quality that lasts.

**MANUFACTURERS:** Your production requirements of General Electric phono-accessories can still be filled. General Electric application engineers have suggestions that will help you design a better product. Call or wire us today for details. *General Electric Company, Parts Section, Electronics Park, Syracuse, New York.*



Type SPX-001

Type UPX-003

General Electric Company, Section 951  
Electronics Park—Syracuse, N. Y.

Please forward information on the G-E phono accessories checked:

Variable Reluctance Cartridges     Replacement Styli     Phono Preamplifiers     Tone Arms

NAME \_\_\_\_\_

ADDRESS \_\_\_\_\_

CITY \_\_\_\_\_ STATE \_\_\_\_\_

**GENERAL ELECTRIC**



DESIGNED FOR  
TV SERVICING



The best way to avoid costly service callbacks on TV electrolytic capacitor replacement jobs is to use Sprague 'lytics.

Actual service records prove they are tops for keeping you out of trouble with service customers—by keeping their TV sets working right!

And Sprague has the most complete listing of every type of television electrolytic.

Write for your catalog today!



# Spot Radio News

\* Presenting latest information on the Radio Industry.

By RADIO & TELEVISION NEWS'  
WASHINGTON EDITOR

**THE TV FREEZE.** which on many occasions seemed to be all set for a general defrosting, but still remained in the locker, may now soon really see that momentous release stage and the end of its three-year stay in the ice cells of Washington, according to the release of an official edict from the Commission.

In an encyclopedic report, noting that the FCC is proposing a . . . "partial lifting of the TV freeze" . . . it was disclosed that a new plan had been prepared providing, technically, for nearly 2000 ultra-high and very-high stations in more than 1200 communities, as compared with about 400 stations in 140 market areas under the present channel assignment plan.

The ultra-high portion of the spectrum received the bulk of the new allocations in the proposal, with from 65 to 70 six megacycle bands suggested, the number depending on a decision, yet to be reached, as to the ultimate use of the 470 to 500 megacycle band (five channels), which the telephone companies have requested for mobile operations. Thus, if the phone utilities do not win the band, the first of the new channels, or Channel 14, will begin at 470; otherwise Channel 14 will be located at 500 megacycles.

A gain of ten channels is indicated in the new plan, or fifty-two against forty-two suggested in the July 11, 1949 program, with thirteen or eighteen channels being set aside for supplemental and experimental work. The intermixing plan, one of the most debated issues during the hearings, appeared to impress the Commissioners, and thus provisions for mixing the ultra-highs and very-highs, or Channels 14 to 65 and 2 to 13, were included in the allocation schedule. Supporting this view, the Commission said that it was reasonable to assume that the economic problems will be faced by broadcasters who enter the new channels, in areas where the two-to-thirteen telecasters are in operation. However, similar problems confronted the very-high broadcasters prior to increased receiver distribution in their respective areas. Therefore, declared the Commissioners, if the entire ultra-high band should be allocated for regular television broadcasting, all receivers will have to be built to receive both types of bands. If the intermixture were avoided, there might be receiver

design and distribution confusion, and it would be necessary to limit many areas to one or two standard band stations, even though ultra-high assignments were available and additional stations could be supported financially, the gentlemen from Washington argued. Moreover, they pointed out, very-high stations are capable of providing a greater coverage than the new band type stations. Hence a more extensive service will become available where some very-high assignments appear in as many communities as possible, than where only very-high assignments appear in some areas, and only ultra-high provisions are made in the other communities. In their opinion, the adoption of any non-intermixture program would constitute a short-term view of the problem.

The new plan will undoubtedly provoke quite a few broadcasters who are being asked to shift their channels. Specifically, there are thirty-one alterations suggested. In Cleveland, Syracuse (New York) and Rochester (New York), the Commission has indicated that WXEL should use Channel 8 instead of 9; WSYR-TV use Channel 3 instead of 5; and WHAM-TV go to Channel 5 and give up Channel 6. These changes were recommended to provide a more equitable distribution of channels between this country and Canada. Interference reduction was offered as the need for the suggested alterations for the remaining 28 channels. In the main, the new assignments involve a shift of a channel above or below. However, there are several who are being asked to accept a healthy switch in frequencies. For instance, WTTV in Bloomington, Indiana, may have to drop to Channel 4, from its present 10; WBKB, Chicago, from 4 to 2; WSB-TV, Atlanta, Georgia, from 8 to 11; WHIO-TV, Dayton, Ohio, from 13 to 7; WJAC-TV, Johnstown, Penna., from 13 to 6; WHAS-TV, Louisville, Kentucky, from 9 to 11; WTAR-TV, from 4 to 10; and WDEL-TV, Wilmington, Delaware, from 7 to 12.

Power increases represent another highlight of the new plan, with population being a major factor in the determination, and interference also being considered. A minimum effective radiated power of 50 kilowatts has been suggested for a station serving a city with a population of a million or more; 10 kilowatts for one catering to



# Service Clinic!

Latest information to help you better service Raytheon

**Gated automatic gain control** has been specially designed for use in TV receivers. This type of A. G. C. is superior because it utilizes a gating horz.-pulse plate supply that eliminates approx. 87% of the noise admittance into the A. G. C. system. Note that the local noise interference shown in Fig. 2 can only be effective during the gated  $I_p$  conduction area shown in Fig. 1 and here the station sync. tips are noise clipped by the 1st video amplifier grid cut-off.

**Gated or keyed A. G. C.** also has another important operating characteristic. The plate gating pulse, being of a time interval corresponding to the station horz. sync. pulse, gates out the station vertical sync. pulse. This greatly reduces the amount of 60 cy component which would normally be injected into the A. G. C. filter. Thus a filter of faster time-constant may be used to reduce airplane flutter.

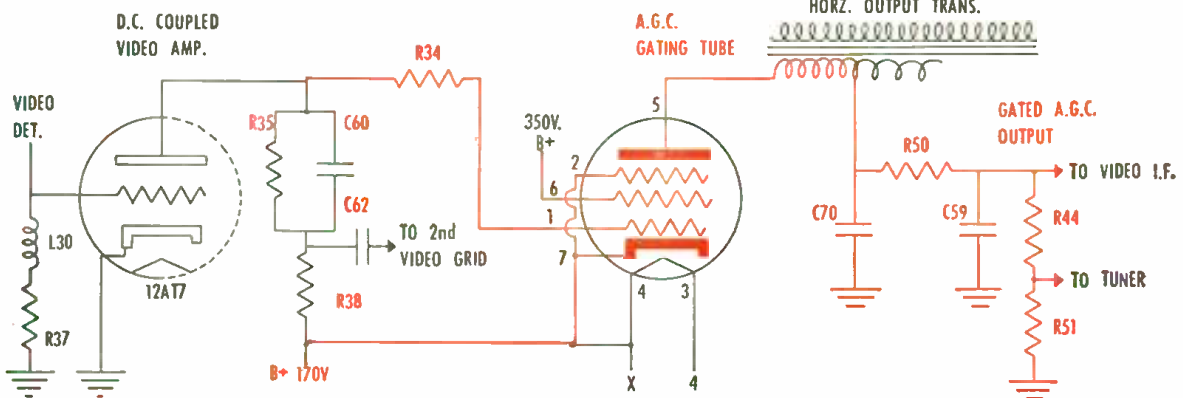

Raytheon's gated A. G. C. circuit above uses a 6AU6 gating tube that is D. C. coupled to the video detector through the 1st video amplifier. The only plate supply is the pulse furnished by the horz. output transformer as shown in Fig. 1. Note that the cathode of the gating tube is tied to B+ (170 volts) and that the grid is directly coupled to the plate of the 12A7 through R34 (R34 reduces grid loading effects on video response). The input signal and D. C. voltage drop (bias), in Fig. 2, developed across the 12A7 plate load (R35, C60 and R38) are applied between the grid and cathode of the gating tube. The plate current supplied by the horz. output transformer passes through the A. G. C. filter (C70, R50 and C59) developing the negative A. G. C. output voltage across R44 and R51.

**Improved circuitry** such as this is one of many reasons why you can feel free to recommend Raytheon TV to a friend or a customer.

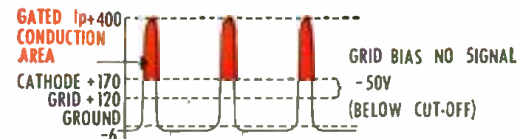

FIG. 1—INSTANTANEOUS PLATE VOLTAGE

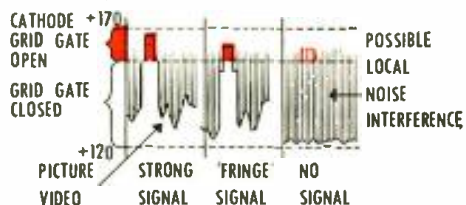

FIG. 2—INSTANTANEOUS GRID VOLTAGE



Belmont Radio Corp., 5921 W. Dickens Ave., Chicago 39, Ill.  
Subsidiary of Raytheon Manufacturing Co.



**Dependably Built for Dependable Performance**



THE STARLIGHT—Model RC-1720

# 3 Grand Mikes!

CATCH EVERYTHING FROM A BABY'S VOICE TO A SYMPHONY ORCHESTRA



HAND OR DESK  
MODEL  
BA-116

BA-109

ALL-PURPOSE  
MODEL  
BA-106

**BA-109** . . . A popular-priced, high-fidelity microphone for PA systems, home recording or other amateur use. Frequency response from 40 to 10,000 cps. Exclusive "Metalseal"<sup>™</sup> crystal assures protection from high humidity. Nondirectional in the horizontal plane . . . output of 54 db below 1 volt/dyne/cm<sup>2</sup>. Fits any standard 5/8" 27-thread stand. List . . . . . **\$22.50.**

**BA-116** . . . Unbeatable at the price . . . rugged, and uniform in response; does not need a stand, but can be used with standard 5/8" 27-thread stand if desired. Brown metallic finish. List, **\$14.75.**

**BA-106** . . . Uses the exclusive "Accusticel"<sup>™</sup> cartridge with the "Metalseal"<sup>™</sup> crystal. Essentially flat frequency response from 40 to 6,000 cps. Output level—50 db below 1 volt/dyne/cm<sup>2</sup>. List, **\$19.75.**

<sup>™</sup>Trade Mark Registered.

**THE BRUSH DEVELOPMENT COMPANY**  
3405 Perkins Avenue • Cleveland 14, Ohio

a population of between 250,000 and a million; 2 kilowatts for service to 50,000 to 250,000; and 1 kilowatt for those areas with a population under 50,000. In each instance, the powers would vary with the heights of the antenna. Super powers may also be permitted, with 100 kilowatts for the 2-to-6 channel stations and 200 kilowatts for all above, or Channels 7 to 83.

Reviewing the city-to-city separations which are believed to be tolerable with higher powers and other changes, the Commission stated that because of the improvements which can result from offset carrier operation, it would only be necessary to have minimum co-channel separation of 180 miles for the 2-to-13 channel stations and 165 miles for the higher-band stations. Previously, separations of 220 and 200 miles had been proposed. For transmitters operating on the same channels, the minimum separation would be 170 miles for the very-high stations and 155 miles for the ultra-high occupants. The adjacent-channel separation scene has been modified, too, with normal separations of 70 miles recommended for the very-high band and 65 miles for the new band stations, instead of 110 and 100 miles previously believed to be necessary. Minimum separation of transmitters operating on the adjacent channels could be 60 miles for the present-band systems and 55 for the newer stations. Generally, declared the Commission, adjacent-channel interference has not been of a serious nature and such problems as do exist can be solved to a very considerable extent by improvements in receiver design, which are neither difficult nor costly. This belief led to the reduction in city-to-city separation, thus making possible a greater number of assignments.

Set manufacturers were told in the report that they were expected to use the 41.25 megacycle intermediate frequency adopted by the RTMA, and that, in addition, efforts were to be made to reduce oscillation radiation.

The territories of Alaska, Hawaii, Puerto Rico, and the Virgin Islands fared quite well in the new-band plan, receiving a full green light for the very-high channels. Alaska was told that she could have fifteen channels; Hawaii, sixteen channels; Puerto Rico, eight channels; and the Virgin Islands, three channels. In addition, channels were set aside for educational purposes. At present, there are no authorizations or pending applications for TV stations in these areas, and it is expected that it won't be long before the race to file will be a merry one.

Education received quite a block of the spectrum in the allocation setup, with two hundred and nine assignments suggested; eighty-two in the very-high and one hundred and twenty-seven in the ultra-high bands. Pointing out that the need for non-commercial educational TV was amply demonstrated during the hearings, (Continued on page 121)

**RADIO & TELEVISION NEWS**



# Proven Performance around the world!



89 countries, 33 governments use Hallicrafters equipment. These precision instruments are prized by experts, remembered by veterans, and preferred throughout the world by short-wave listeners who want a radio that is all radio.



Model SX-62

**Model SX-62**—World's finest receiver for the all-wave listener. Outperforms any broadcast receiver on any frequency—continuous coverage from 540 kc to 109 Mc in six bands. Crystal calibration oscillator built in. Six position selectivity with crystal filter. Two stages r-f, three stages i-f amplification. 10-watt push-pull high fidelity output. Phonograph jack, 14 tubes plus regulator and rectifier. . . . . \$289.50



Model SX-71

**Model SX-71**—Value-packed with features specifically asked for by the Hams. Extra sensitivity, selectivity, and stability; double super-heterodyne, plus built-in, Narrow Band FM. One r-f, two conversion, and three i-f stages. Range 538 kc to 35 Mc, 46-55 Mc. Extra wide dials for Main and Bandspread Tuning. Sensitivity, Volume, BFO Pitch, Selectivity, and Crystal Phasing controls. AVC, BFO, Rec./Standby, ANL Tone, and Phono-Rec. switches. Phonograph input jack. 500, 3.2-ohm output. . \$199.50



Model S-76

**Model S-76**—The only double superhet with 50 kc second i-f and the only set now known with a giant sized 4-inch "S" meter. Another new Hallicrafters engineering triumph. One r-f, two conversion, and two i-f stages; temperature compensated, voltage regulated. Range 540-1580 kc, 1.72-32 Mc in four bands. Separate electrical bandspread, with calibrated dial. Sensitivity, Volume, BFO Pitch, Selectivity and Tone Controls: AVC, Rec./Standby, BFO, ANL switches. Phonograph input jack. 3.2 or 500 ohm outputs. 9 tubes plus voltage regulator and rectifier. \$169.50



Model S-40B, S-77

**Model S-40B, S-77**—New version of an old favorite. Temperature compensated oscillator; tuned r-f stage, two i-f stages for better selectivity. Covers 540 kc to 43 Mc in four bands. Sensitivity, volume, three-position Tone, BFO Pitch, controls; AVC, BFO, Rec./Standby, and Noise Limiter Switches. Built-in PM speaker. External power, remote control connections. 7 tubes plus rectifier. . . . . \$99.95



S-72, S-72L

**Model SR-75**—A small transceiver for the novice class or beginning amateur; can also be used later as exciter unit. Receives on 540 kc through 32 Mc, transmits on 10, 11, 20, 40, or 80 meter bands. 10 watts input to final amp. Receiving section is substantially same as our S-388 Bandspread tuning. Speaker phones switch, BFO switch, Rec./Standby switch; four tubes plus rectifier. Transmitting section uses electron coupled Xtal oscillator plus output tube of receiver. Voltage doubler rectifier to increase plate voltage. 5 tubes plus rectifier. With coils, less crystals. . . \$89.95



Model SR-75

**Model S-388**—Pulls in broadcast stations in weak signal areas where ordinary sets fail. Also offers world-wide reception for the short-wave listener and the new amateur. Covers Broadcast Band and three short-wave bands. 540 kc to 32 Mc. Separate Fine Tuning control, BFO, Rec./Standby. Speaker/Phones switches. Built-in PM speaker. Four tubes plus rectifier. For 115 V. AC or DC. \$49.50



Model S-388

**S-72**—One stage r-f, two stages i-f amplification. Built-in loop antenna for broadcast, plus 61" collapsible whip for short-wave. Band-spread tuning knob for separation of short-wave stations. Sensitivity control combined with code (BFO) switch, Jack for headphones. Brown leatherette cabinet, space inside for power cord and headphones. 8 tubes plus rectifier. Less batteries. For 115 V, AC or DC or batt. 540 kc. to 305 Mc. in 4 bands. . . . \$109.95  
**S-72L (Long Wave Model)**—Marine Beacons, Aircraft Ranges, Towers 175-420 kc., Plus 540 kc. 12.5 Mc. \$119.95



World's Leading Manufacturers of Precision Radio & Television, Chicago 24, Illinois

Visit Booth #576, Radio Parts Show, Stevens Hotel, Chicago, Illinois

# Which Do You Want?



Better Pay



A Nice Home



A New Car



Greater Security



Happy Vacations and Travel

Get Your FCC Ticket  
Then Use Our  
Amazingly Effective  
Job-Finding Service  
To Get a Better Job

Add Technical Training to Your Practical Experience and

# Get Your FCC COMMERCIAL RADIO OPERATOR LICENSE

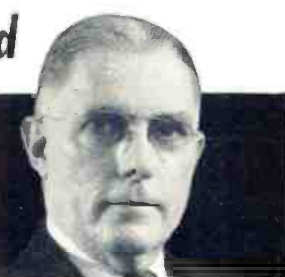

I can train you to pass your FCC License Exams in a few short weeks if you've had any practical radio experience—amateur, Army, Navy, radio servicing or other. My time-proven plan can help put you, too, on the road to success.

Let me send you FREE the entire story. Just fill out the coupon and mail it. I will send you, free of charge, a copy of "How to Pass FCC License Exams," plus a sample FCC-type Exam, and the amazing new booklet, "Money Making FCC License Information."

Edw. H. Guilford  
Vice President

in a Minimum of Time

Get this Amazing Booklet FREE

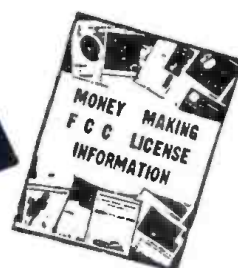

TELLS HOW—

WE GUARANTEE

TELLS HOW—

TO TRAIN AND COACH YOU AT HOME  
IN SPARE TIME UNTIL YOU GET

**YOUR FCC LICENSE**

**Our Amazingly Effective  
JOB-FINDING SERVICE**

Helps CIRE Students Get Better Jobs

Here is just one recent example of Job-Finding Results

Gets Five Job-Offers From Broadcast Stations

"Your 'Chief Engineer's Bulletin' is a grand way of obtaining employment for your graduates who have obtained their 1st class license. Since my name has been on the list, I have received calls or letters from five stations in the southern states, and am now employed as Transmitter Engineer at WMMT."

Elmer Powell, Box 274, Sparta, Tenn.

Your FCC Ticket is always recognized in all radio fields as proof of your technical ability.

TELLS HOW—

Employers Make

**JOB OFFERS Like These  
to Our Graduates Every Month**

Telegram, August 9, 1950, from Chief Engineer, Broadcast Station, Pennsylvania. "I have job opening for one transmitter operator to start immediately, contact me at once."  
Letter, August 12, 1950, from Dir. Radio Div., State Highway Patrol. "We have two vacancies in our radio communication division. Starting pay \$200; \$250 after six months' satisfactory service. Will you recommend graduates of your school?"  
Letter, August 24, 1950, from radio-television sales and service company, Ohio. "We are in need of a good television man. The pay will be good, also good surroundings to work in. Please let us hear from you."  
These are just a few examples of the job offers that come to our office periodically. Some licensed radioman filled each of these jobs . . . it might have been you!

**HERE'S PROOF FCC LICENSES ARE OFTEN SECURED  
IN A FEW HOURS OF STUDY WITH OUR  
Coaching AT HOME in Spare Time**

Name and Address	License	Lessons
Lee Worthy 2310 1/2 Washire St., Bakersfield, Cal.	2nd Phone	16
Clifford E. Voigt Box 1018, Dania, Fla.	1st Phone	20
Francis K. Faerch	1st Phone	38
38 Heuler Pl., Bergenfield, N. J.		

**CLEVELAND INSTITUTE OF RADIO ELECTRONICS**  
Desk RN-29, 4900 Euclid Bldg., Cleveland 3, Ohio  
(Approved for Veteran Training Under "GI Bill of Rights")

OURS IS THE ONLY HOME STUDY COURSE WHICH SUPPLIES FCC-TYPE EXAMINATIONS WITH ALL LESSONS AND FINAL TESTS.



Get All 3 FREE

MAIL COUPON NOW

Cleveland Institute of Radio Electronics  
Desk RN-29—4900 Euclid Bldg., Cleveland 3, Ohio  
(Address to Desk No. to avoid delay)

I want to know how I can get my FCC ticket in a minimum of time. Send me Your FREE booklet, "How to Pass FCC License Examinations" (does not cover exams for Amateur License), as well as a sample FCC-type exam and the amazing new booklet, "Money-Making FCC License Information."

Name \_\_\_\_\_  
Address \_\_\_\_\_  
City \_\_\_\_\_ Zone \_\_\_\_\_ State \_\_\_\_\_

Paste on penny postcard or send air mail.

RADIO & TELEVISION NEWS



"HURRY, HURRY, HURRY!  
DON'T MISS THIS NEW,  
SIMPLIFIED SERVICING BOOK!"

**FREE!**

**only until May 31st ...  
with the purchase of one  
Sylvania Picture Tube!**

Don't let this offer expire without your getting a copy of this splendid, fact-packed servicing manual. Filled with time-saving shortcuts and valuable servicing hints.

Now it's yours absolutely FREE from your Sylvania Distributor with the purchase of just one Sylvania Picture Tube, of any type. But the offer expires May 31st. So, act NOW! Write or call your distributor TODAY!

**SAVES TIME! SAVES MONEY! SOLVES  
SCORES OF SERVICING PROBLEMS!**

This book contains 48 pages of pictures, diagrams, and easy-to-follow instructions covering:  
**Radio Servicing** . . . Signal Tracing, Alignment, AVC and AFC Checking, Measurement of Voltages, Signal Levels, Power Output, Band Width and much more.

**TV Servicing** . . . Signal Tracing, Bandwidth Measurements, Wavetrapp Checking, Sound Channel Tests and Alignment, Low and High Voltage Checks, Signal and Deflection Voltage Measurements, and numerous other subjects.

**Audio Amplifier Servicing** . . . DC, AC, and Signal Level Measurements; Tone Control, Fidelity, Gain Tests, Distortion, Power Output, and Noise Level Measurements; Signal Tracing, and Speaker Matching.

**Miscellaneous Applications** . . . 19 different applications of VTVM including Detecting Gassy Tubes, Checking Capacitors, Q Measurement, Turns Radio Measurement, Impedance Checking.

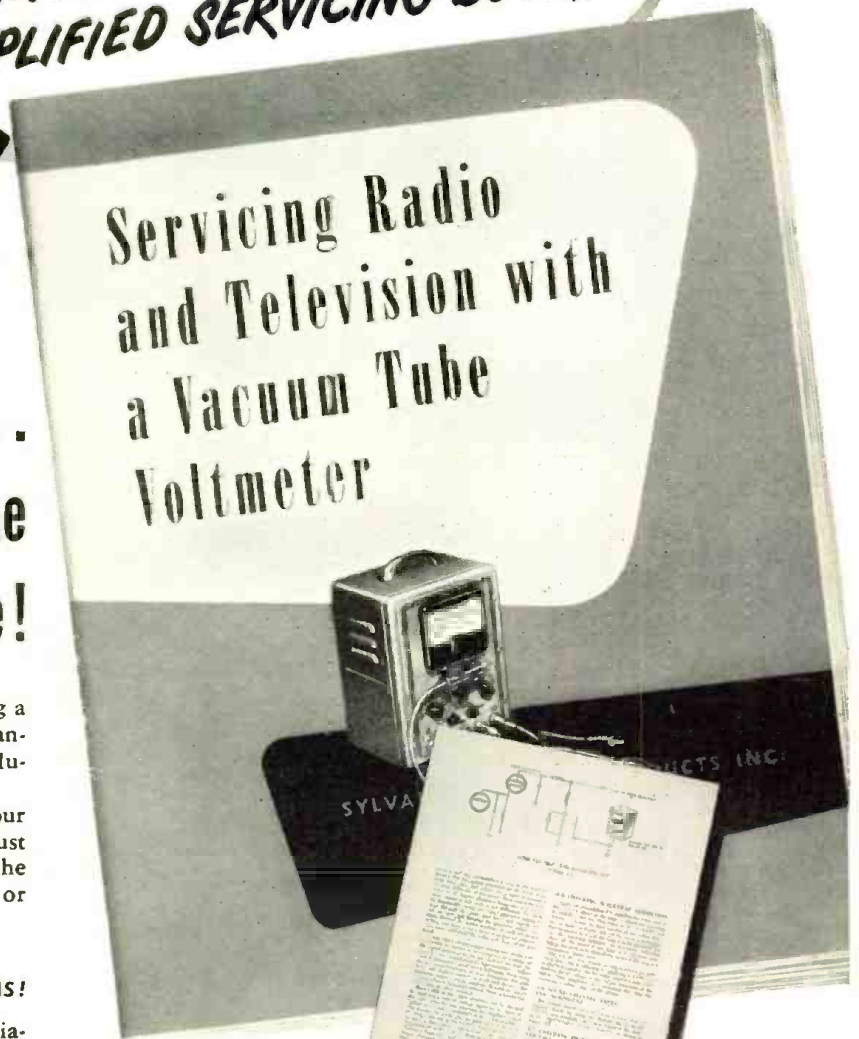

"DON'T DELAY,  
CALL YOUR  
SYLVANIA DISTRIBUTOR  
NOW!"

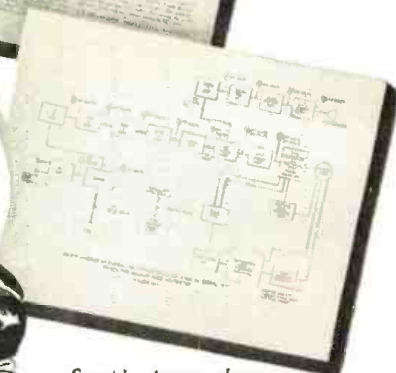

Sample pages showing detailed, easy-to-read diagrams.



**SYLVANIA ELECTRIC**

RADIO TUBES; TELEVISION PICTURE TUBES; ELECTRONIC PRODUCTS; ELECTRONIC TEST EQUIPMENT; FLUORESCENT TUBES, FIXTURES, SIGN TUBING, WIRING DEVICES; LIGHT BULBS; PHOTOLAMPS; TELEVISION SETS

May, 1951

19

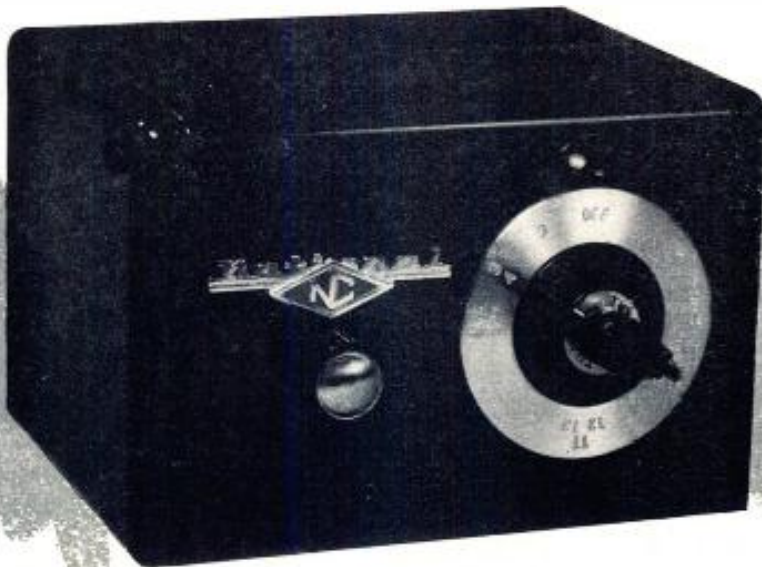

MODEL TVB-2B

## The New Improved NATIONAL TELEVISION BOOSTER MAKES THIS MUCH DIFFERENCE!

The new, improved National Television Booster adds a true stage of RF amplification to any TV set.

If the signal is low, but perceptible, this booster will greatly increase brightness, contrast and definition — open up whole new areas to good TV reception! Housed in a smart metal cabinet finished in special wear-resistant mahogany enamel.

**\$39.95** list

### COMPARE THESE FEATURES:

- (1) Turret tuner with individually-tuned set of coils for each channel.
- (2) Removable polystyrene coil-mounting contact panels.
- (3) A single 6AK5 for maximum gain with minimum noise level.
- (4) Built-in power transformer (not AC-DC).
- (5) Selenium rectifier for long life.
- (6) Fine tuning control in addition to channel selector.
- (7) Pilot light illuminates selected channel.



# TRIPLETT

## Load-Chek

introduces  
**Servicing  
by  
Power  
Consumption**

**MODEL 660**



**LOAD-CHEK** for the first time makes it possible for every technician to utilize what is perhaps the simplest and quickest of all service methods—Servicing by Power Consumption Measurements.

Power consumption measurement has long been proved by auto-radio servicemen as a rapid method of localizing troubles in auto radios. But Triplet's new **LOAD-CHEK** is the first Wattmeter to be produced at moderate cost, and with the proper ranges, to bring this short-cut method within the reach of every radio and TV service man.

Basis of the **LOAD-CHEK** method is the tag or label on every radio and TV chassis which shows the normal power consumption. The following examples are only two of many time-saving uses of this new instrument.

**LOCATING A SHORT**—The chassis tag may show a normal consumption of 225 Watts. Simply plug the power cord of the chassis into **LOAD-CHEK** (there are no loose ends to connect or be in the way). Note the reading—which should be possibly 350 Watts. By removing the

rectifier tube you can determine at once which side of the tube the short is on. With a soldering iron and long-nosed pliers you can check through the chassis, locate and correct the trouble without having to lay down tools or to check with lead wires!

**REPLACING BURNED OUT RESISTORS**—With the chassis to be repaired plugged into a **LOAD-CHEK MODEL 660**, note the wattage reading with the burned out resistor circuit open. Now replace the resistor. Should the increase in watts be greater than that of the resistor rating being installed, it indicates that an extra load has caused the trouble which has not been cleared.

**LOAD-CHEK** is made-to-order for the busy service man and can help stop costly "come back" repair jobs. It's a profit-maker because it's a Time-Saver. And at its moderate cost **LOAD-CHEK** can be standard equipment on every service bench. By all means, inspect this versatile instrument at your distributor and place your order, for under present conditions we must fill all orders on a basis of "First Come, First Served."

SEE MODEL 660 **LOAD-CHEK** AT YOUR DISTRIBUTOR'S

FOR THE MAN WHO TAKES PRIDE IN HIS WORK

# Triplet

TRIPLETT ELECTRICAL INSTRUMENT COMPANY • BLUFFTON, OHIO, U.S.A.

# "This Seal means a 'Good Deal' to me!"

"My Television and Radio sets are pretty big investments to me. That's why I insist that they be serviced by a Raytheon Bonded Electronic Technician — a technician whose work is backed by a cash bond — whose skill and integrity are above reproach."

The RAYTHEON *Bonded* Electronic Technician Program means a *good deal* to you, too. If you can qualify for this important honor, your 90-day guarantee on TV and Radio repairs is cash-protected up to \$400.00 by a *bond*. You receive a Registered Certificate, Identification Cards, Creed Displays and Decals and a host of other sales helps and shop aids — all designed to tell the world you're a completely capable, thoroughly reliable service dealer — a dealer with whom customers can deal with complete confidence. And yet, this great sales stimulator *costs you nothing* — it's Raytheon's *investment in your future*.

If you're interested in getting head and shoulders above your competitors, better ask your Raytheon Tube Distributor if you can qualify for this exclusive sales asset.



RIGHT... for  
SOUND and SIGHT

**RAYTHEON MANUFACTURING COMPANY**

Receiving Tube Division

Newton Mass., Chicago, Ill., Atlanta, Ga., Los Angeles, Calif.

RADIO AND TELEVISION RECEIVING TUBES, CATHODE RAY TUBES, SPECIAL PURPOSE TUBES, SUBMINIATURE TUBES, MICROWAVE TUBES

COPYRIGHT 1954



*Excellence in Electronics*

# MOST POWERFUL

## ANTENNA COMBINATION IN TV HISTORY

**SINGLE  
CHANNEL**

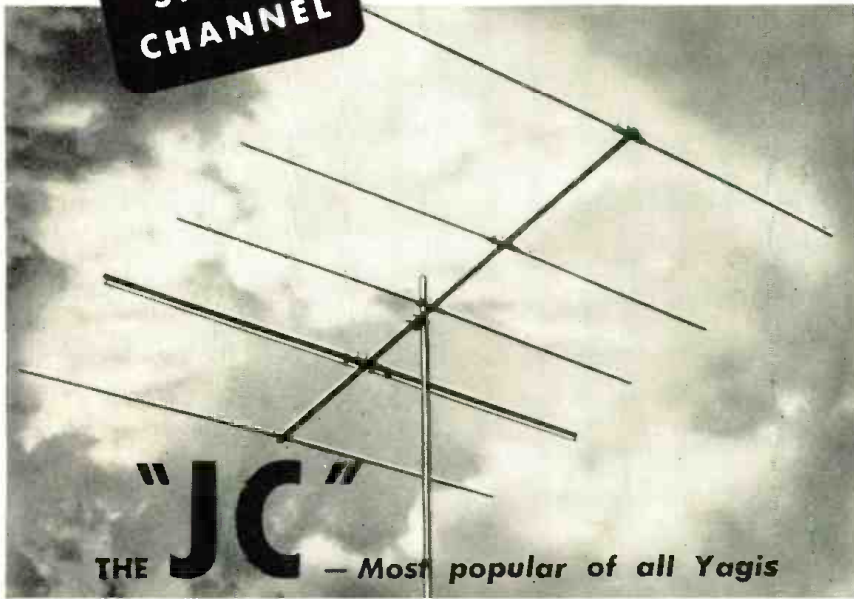

**"JC"**  
THE — Most popular of all Yagis

**ALL  
CHANNEL**

### COLINEAR ARRAY

*The New Favorite  
in Areas Where Both High and Low  
Channel Reception is Required*

This exclusive Vee-D-X antenna was developed to fill the need for more powerful all-channel reception in primary as well as fringe areas. Besides producing higher gain throughout the TV spectrum, the Colinear may be cut to any single high channel for sharp directivity, yet will resonate on low channels regardless of high channel selected. Like the Vee-D-X JC Yagi, the Colinear is completely pre-assembled. It is also the lowest priced four-bay array ever manufactured.

### NEW Stacked Arrays

#### PRODUCE SHARP, CLEAR PICTURES AT AMAZING DISTANCES

Vee-D-X — largest producer of Yagis — brings you new stacked arrays that provide still higher gain and further reduce noise interference. Perfected by Vee-D-X engineers in collaboration with a foremost authority on wave propagation, these stacked arrays make a world of difference in picture quality. In addition to the already popular double stacked array ("A" below) with half-wave spacing, you can employ double stacked arrays with full-wave spacing ("B" below) and half-wave four stacked, either vertical or side-by-side. Choice of array depends on area terrain and reception conditions.

#### POWERFUL STACKED ARRAYS FOR ALL SINGLE CHANNEL REQUIREMENTS

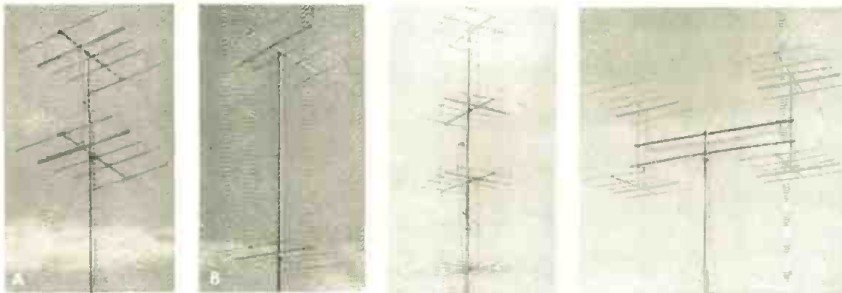

(A) Double Stacked JC Array with half-wave spacing. Provides additional gain and improved signal-to-noise ratio.  
 (B) Double Stacked JC Array with full-wave spacing. Provides highest possible gain in low noise areas.  
 (C) Four Stacked Vertical JC Array provides extremely high gain and excellent improvement of signal-to-noise ratio. Ideal for long distance reception areas with relatively flat terrain.  
 (D) Four Stacked Side-by-side JC Array — a radically new type of array developed for highest gain in hilly and mountainous terrain. Provides powerful long distance reception.

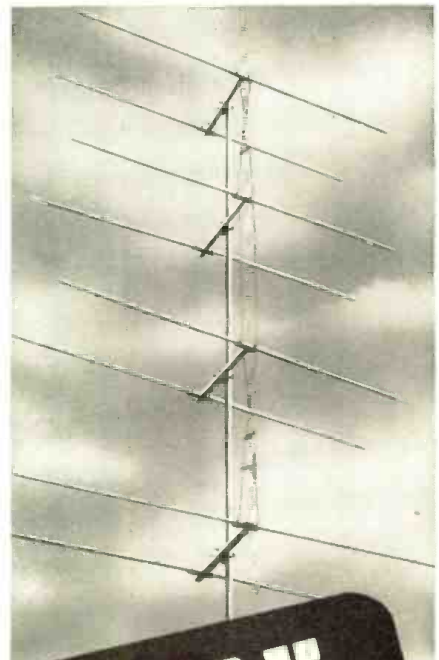

**VEE-D-X**  
THE WORLD'S  
MOST POWERFUL ANTENNAS

THE LaPOINTE - PLASCOMOLD CORPORATION, WINDSOR LOCKS, CONNECTICUT  
May, 1951

# *Now..* **CENTRALAB OFFERS POPULAR MAKE TV**



**➡ CENTRALAB CUSTOM CONTROLS ARE MADE BY THE OLDEST NAME IN CARBON CONTROLS.** Centralab custom controls are made by Centralab, the company that introduced carbon controls to the radio industry — *25 years ago!*

**➡ CENTRALAB CUSTOM CONTROLS ARE FACTORY ASSEMBLED AND TESTED — QUICKEST FOR SERVICING.** All Centralab custom controls for TV are factory assembled and tested—including switches. They're made to exact replacement specifications and come ready to install.

**➡ CENTRALAB CUSTOM CONTROLS SAVE YOU VALUABLE TIME — HELP GUARANTEED SERVICE.** Because Centralab Custom Controls come to you ready to install — there's no time lost fumbling around with kit assemblies. What's more, you can be confident of giving guaranteed service with factory-tested controls.

**➡ CENTRALAB CUSTOM CONTROLS OBTAINABLE FROM ONE SOURCE.** You'll find these Centralab Custom Controls for TV replacement are regularly stocked by leading independent parts distributors. There's no time lost in "shopping around" for the exact replacement part.



# CUSTOM CONTROLS FOR SERVICE REQUIREMENTS

PLAIN TYPE STANDARD TWIN

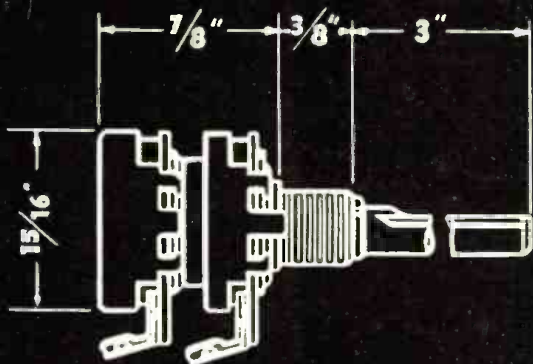

TAP BASE

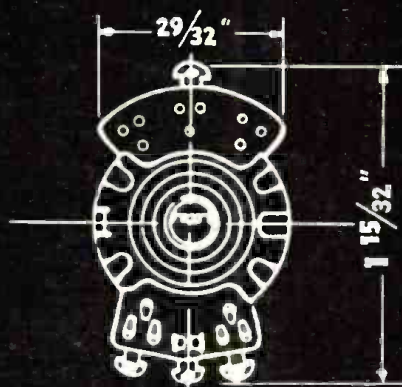

DUAL CONCENTRIC SHAFT SWITCH TYPE

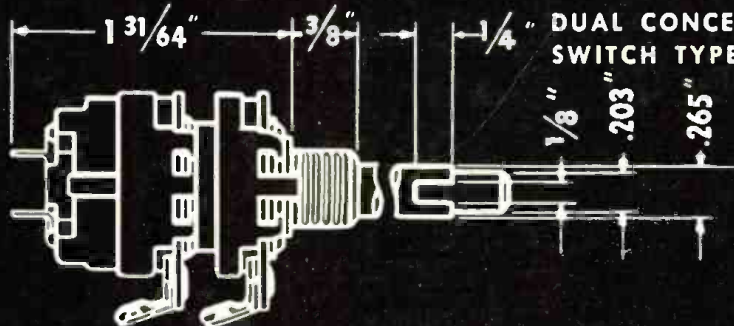

## CENTRALAB HELPS YOU SOLVE TV SERVICE PROBLEMS

Along with Centralab's Custom Controls for TV replacement comes another big help to service engineers — Centralab's new TV CONTROL GUIDE. It will save you time, money and energy . . . no more "shopping around" for the exact replacement you need. The Centralab TV CONTROL GUIDE contains over 1600 listings of exact replacement

controls for nearly all popular makes and models. PLUS — AND THIS IS A BONUS FOR YOU — the industry's first replacement listing on Centralab's famous Printed Electronic Circuits! Use the coupon to get your copy of Centralab's new TV CONTROL GUIDE. It gives many dollars' worth of valuable information for only 25¢.

# Centralab

Division of GLOBE-UNION INC., Milwaukee



**NEW!**

**TV CONTROL GUIDE**

WITH FIRST LISTING OF PEC'S

**MAIL TODAY**

CENTRALAB DIV. OF GLOBE-UNION INC.  
910 East Keefe Avenue, Milwaukee 1, Wisconsin

I enclose 25¢ in stamps or coin for my copy of the new Centralab TV Control Guide which has over 1600 exact listings, plus the industry's first listing of Printed Electronic Circuits.

Name.....

Address.....

City..... Zone..... State.....

Please! I am a  Service Engineer  Ham  Jobber  TV Set-Owner

# new!

ACTUAL  
SIZE

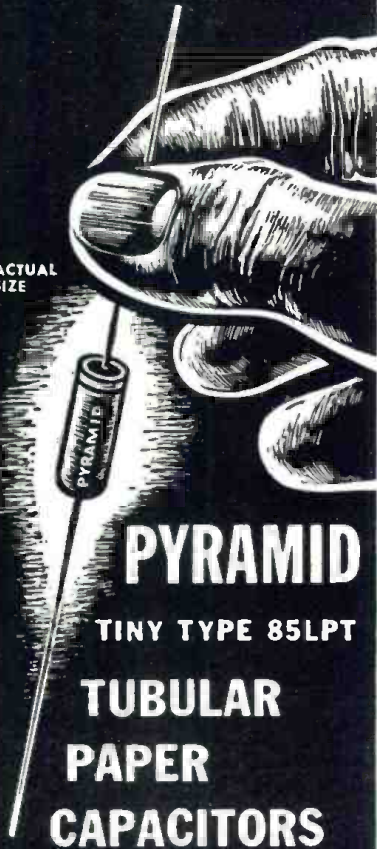

## PYRAMID TINY TYPE 85LPT TUBULAR PAPER CAPACITORS

Fit anywhere!  
Suitable for  
85°C. operation!

CAPACITANCE RANGE:  
.0001 TO .5 MFD.

VOLTAGE RANGE:  
200 TO 600 V., INCLUSIVE

Sturdily built in phenolic-impregnated tubes. Ends are plastic-sealed.

WRITE FOR COMPLETE LITERATURE  
Representatives and Distributors  
Throughout the U.S.A. and Canada



## PYRAMID

### PYRAMID ELECTRIC COMPANY

1445 Hudson Boulevard  
North Bergen, N. J., U. S. A.

TELEGRAMS: WUX North Bergen, N. J.  
CABLE ADDRESS: Pyramidusa

# Within the INDUSTRY

EDWIN B. HINCK has been appointed sales manager of the electronic parts division of *Allen B. Du Mont Laboratories, Inc.*

He succeeds Major Harry Van Rensselaer who has recently been recalled to active duty with the Army Air Force.



Mr. Hinck, active in the electronic industry for the past ten years, has been associated with *Du Mont* since 1943. Aside from his experience in the electronic parts division, at one time Mr. Hinck was northeast sales manager for the transmitter division, covering the territory east of Pittsburgh.

In his new post, Mr. Hinck will be responsible for the introduction and sale to the public of the new products and components manufactured by the division.

\*\*\*  
**THE BELL SYSTEM** has announced that network television has been extended to Binghamton, New York, the 43rd such city receiving network service.

Programs reaching Binghamton travel on both coaxial cable and radio relay. The television signals go over the coaxial facilities as far as Albany where they take to the microwaves and are carried along the Albany-Syracuse radio relay route. At Cherry Valley, New York, two relay points west of Albany, the signals are beamed south to Binghamton via new relay stations at New Berlin and Windsor.

Unlike most relay stations which have antennas mounted on top, the New Berlin and Windsor towers are mounted with 10 by 15 foot aluminum reflectors. Signals from Cherry Valley strike the first reflector and are bounced to a receiving antenna at the base of the tower. After passing through amplifying equipment the signals are beamed from a ground level transmitting antenna which beams them to another reflector and thus on to the next station. The reflector tower at New Berlin is 300 feet high and that at Windsor is 150 feet.

\*\*\*  
**FREDERICK HART & CO., INC.** of Poughkeepsie, New York, has announced that the name of the 57-year-old electronics equipment firm has been changed to the **DAYSTROM ELECTRIC CORPORATION**. The move was in line with the change of the parent company name from **ATF INCORPORATED** to **DAYSTROM, INCORPORATED**. . . . A new television manufacturing firm, known as **CADILLAC ELECTRONICS CORP.** has been formed by I. R. Ross.

The new organization has headquarters at 3 West 61st Street in New York . . . The newly organized **RADIOPHON CORP.** of New York is the United States affiliate of the French firm **ETS RADIOPHON** of Paris. The company will act as agents for European made radio and electronic parts . . .

**CENTRAL TRANSFORMER COMPANY**, with Morton R. Whitman as president and Lloyd G. Shore as secretary-treasurer, has been recently organized in Chicago. The firm, which is located at 910 W. Jackson Boulevard, Chicago 7, Illinois, will specialize in custom transformer design and manufacture . . .

**GEM ELECTRONICS DISTRIBUTORS INC.** has recently opened its doors at 236 Broadway, Hickville, Long Island to handle the distribution of radio, television, and electronic items in the Long Island area . . .

**THE SOUTHWESTERN COMPANY, INC.**, of Dallas, Texas, has announced a change in the corporate name to **MEDARIS COMPANY, INC.**

No other changes in policies, officers, etc., are involved. The company will continue to operate at 1202 Dragon Street, Dallas . . .

**TRACERLAB, INC.**, of Boston has announced the consolidation of that firm with **THE KELLEY-KOETT MANUFACTURING COMPANY** of Covington, Ky., and Cincinnati, Ohio. Plans call for the continued operation of both firms under present management.

\*\*\*  
**W. G. MANY**, who for the past twelve years has been advertising and sales promotion manager

of the *Cornell-Dubilier Corporation*, of South Plainfield, New Jersey and editor of the company's "C-D Capacitor" has resigned from his post to serve as a public relations counsellor.



He will conduct a personalized public relations service handling sales and engineering catalogues, literature, house organs, publicity, advertising, and other related promotion activities for electronic and photographic equipment manufacturers.

For the time being Mr. Many is headquartered at his home in Metuchen, New Jersey until suitable facilities can be located elsewhere.

\*\*\*  
**R. O. BULLARD** has been appointed manager of manufacturing of the *General Electric Tube Divisions* . . .

**CHARLES A. NICHOLS** has been promoted to the newly-created post of director of engineering for *Packard-*

**RADIO & TELEVISION NEWS**

# NEW ELECTROSTATIC RECTANGULAR 20FP4



ANOTHER  
**HYTRON FIRST**  
FOR YOU

To its logically designed original *studio-matched* rectangular, Hytron now adds new advantages: the cobalt-and-copper savings of electrostatic focus.

The original Hytron electrostatic type 20FP4 eliminates the magnetic focus unit. Uses a single-field ion-trap magnet. Yet the 20FP4 gives you unsurpassed, clear, sharp pictures . . . despite economies in associated components enforced by defense needs.

Seeing is believing. Watch for this newest Hytron first from the world's most modern picture-tube plant. You'll be seeing it, buying it soon. You'll marvel at its sharp pictures, even at lower line voltages.

Again you'll say it pays to stay out front in picture tubes. It pays to insist on Hytron's original *studio-matched* rectangulars . . . choice of 9 out of 10 leading TV set makers.



MAIN OFFICE: SALEM, MASSACHUSETTS

HAVE YOU  
GOT YOUR COPY?

The new 5th edition of the Hytron Reference Guide for Miniature Electron Tubes is out. See your Hytron jobber. Get your free copy of this old friend brought up to date today.



It's only natural  
that the largest  
**PRODUCER\*** of  
switch-type tuners  
should produce  
the **BEST!**

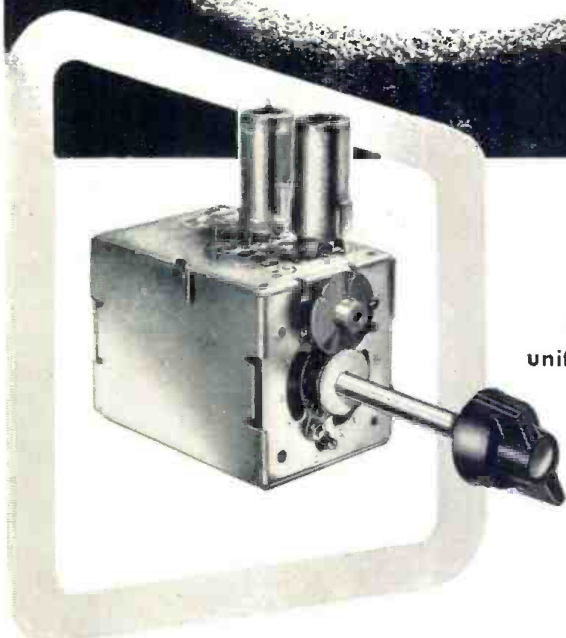

No other commercial  
unit possesses all of the  
Desirable Features  
found in the

**Tarzian  
Tuner!**



**SARKES TARZIAN, INC.**  
TUNER DIVISION  
Bloomington, Indiana

**OTHER TARZIAN-MADE PRODUCTS**



Centre-Kooled  
Selenium Rectifiers

Air Trimmers

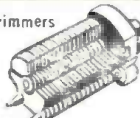

Cathode-Ray  
Tubes



**STATIONS WTTT (5000 WATTS) AND WTTV (CHANNEL 10)  
OWNED AND OPERATED BY SARKES TARZIAN IN BLOOMINGTON**

Bell while **RICHARD G. LEITNER**, who has rejoined the company after an 18 years' absence, has been named chief research engineer . . . **JAMES B. LINDSAY** has been elected vice-president and director of engineering of *Thomas Electronics, Inc.*, Passaic manufacturer of television tubes . . . **H. H. SCUDDER** and **A. U. PINKNEY** have been named vice-presidents of the *International Standard Electric Corporation* . . . **R. M. BUTLER** has been promoted to the post of assistant sales manager of the merchandise division of *International Resistance Company* of Philadelphia . . . **GEORGE P. ALDRIDGE** is the new vice-president in charge of sales and government contracts for *Radiomarine Corporation of America* . . . **RAY F. CREWS** has been appointed vice-president in charge of sales for the *Fairchild Recording Equipment Corporation* of Whitestone, New York . . . **ED MOREY** has been placed in charge of sales for *Wilcox-Gay Corporation* . . . **GEORGE A. ENGELBERT** has been upped to section chief of the technical publications for *Bendix Radio Division* . . . **WILL BALTIN**, who has served as secretary-treasurer of the *Television Broadcasters Association, Inc.*, from its inception in 1944, has resigned to join *Screen Gems*, the television subsidiary of *Columbia Pictures Corporation* . . . **JEROME TANNENBAUM** has joined *Concord Radio Corporation* as chief engineer of the audio division . . . **HAROLD M. STRAL** has been named advertising manager for *Standard Transformer Corporation* . . . The newly-created post of director of purchases for *Erie Resistor Corporation* is being filled by **GEORGE M. SCHAU** . . . **JOHN S. MILLS** has been elected vice-president of *Tele-Tone Radio Corporation* . . . The *Hallcrafters Company* of Chicago has made three executive appointments of interest to the industry. **R. W. WESTERFIELD** has been named director of procurement. **J. C. MATHEWS** is the new purchasing agent while **ROBERT F. HALLIGAN** will serve as the chief purchasing expediter.

\* \* \*

**WILLIAM P. SHORT** has been named chief engineer of *General Precision Laboratory of Pleasantville, New York*.



In his new post Mr. Short will supervise production of the company's electronic and optic equipment as developed by the research division.

The new executive, who has been in the electronics field for 22 years, was awarded the Presidential Certificate of Merit for his wartime record as chief engineer of the *Research Construction Company, Inc.* of Cambridge, Mass.

\* \* \*

**THE INSULINE CORPORATION OF AMERICA** has just opened a third fac-  
(Continued on page 150)

**RADIO & TELEVISION NEWS**

Floyd Makstein, field engineering manager at **Emerson** recommends

# Simpson

MODEL 480 GENESCOPE

## FOR TV-FM SERVICING

This is what Floyd Makstein of EMERSON says about the Simpson Model 480 Genescope: . . . "The Simpson Model 480 Genescope far surpasses the standards required in the servicing and aligning of all TV-FM receivers. The wide frequency response and the 25 millivolt sensitivity of the oscilloscope, combined with the required fundamental signal sources which are provided in the AM & FM oscillator sections, simplifies the accurate aligning of all TV receivers, including those with intercarrier systems. In addition, the large, easy-to-read dials, having a 20-1 vernier control and 1000 division logging scale, cuts down on servicing time."

Mr. Makstein concludes . . . "The compactness of the complete unit will be a big factor in many of the service shops where space is at a premium. We are sure that the whole TV industry appreciated your efforts in raising the engineering standard in servicing." Emerson Service personnel know that modern FM and TV development and servicing demand test equipment made to the most exacting standards. They prefer the Simpson Model 480 Genescope because it is the most accurate, flexible and convenient instrument available. The Genescope will render many years of uninterrupted service and always produce accurate results.

### SIMPSON ELECTRIC COMPANY

5200 W. Kinzie St. • Chicago 44, Illinois • Phone: COlumbus 1-1221

In Canada: Bach-Simpson, Ltd., London, Ont.

THESE RANGES SHOW HOW  
MUCH THE SIMPSON GENESCOPE CAN DO FOR YOU

#### FREQUENCY MODULATED OSCILLATOR

Band A: 2-120 megacycles  
Band B: 140-260 megacycles  
Sweep width variable from zero to 15 megacycles  
Sweep rate 60 cycles per second  
Specially designed frequency sweep motor  
Continuously variable attenuator  
Crystal calibrator:  
5 megacycles  $\pm$  .05%  
Audio Oscillator 400 cycles  
Output Impedance 75 ohms  
Step attenuator for control of output

#### AMPLITUDE MODULATED OSCILLATOR

Band A: 3.3-15.6 megacycles  
Band B: 15-75 megacycles  
Band C: 75-250 megacycles  
30% modulation at 400 cycles or unmodulated  
Continuously variable attenuator  
Visual method of beat frequency indication

#### OSCILLOSCOPE

Vertical sensitivity:  
25 mv per inch  
Horizontal sensitivity:  
70 mv per inch  
Linear sweep frequency:  
2 cycles to 60 kilocycles  
60 cycle sine sweep  
Frequency essentially flat to 200 KC. usable to over 3 megacycles

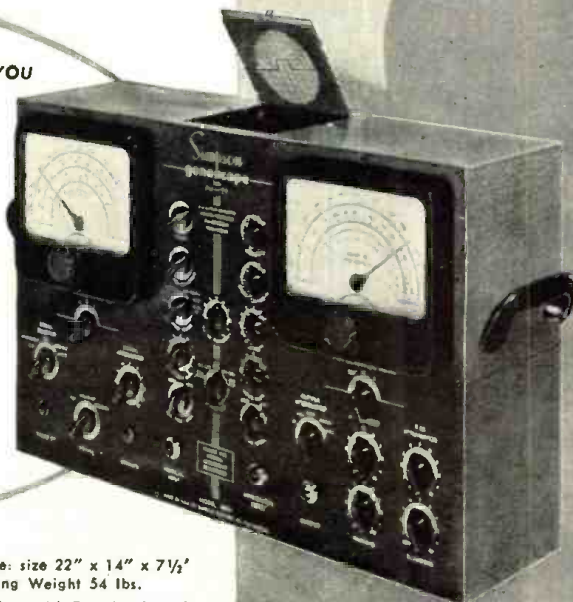

Simpson Model 480 Genescope: size 22" x 14" x 7 1/2"  
Weight 45 lbs. Shipping Weight 54 lbs.

DEALER'S NET PRICE complete with Test Leads and Operator's Manual, \$395.00.



This "gun" shoots wire around corners

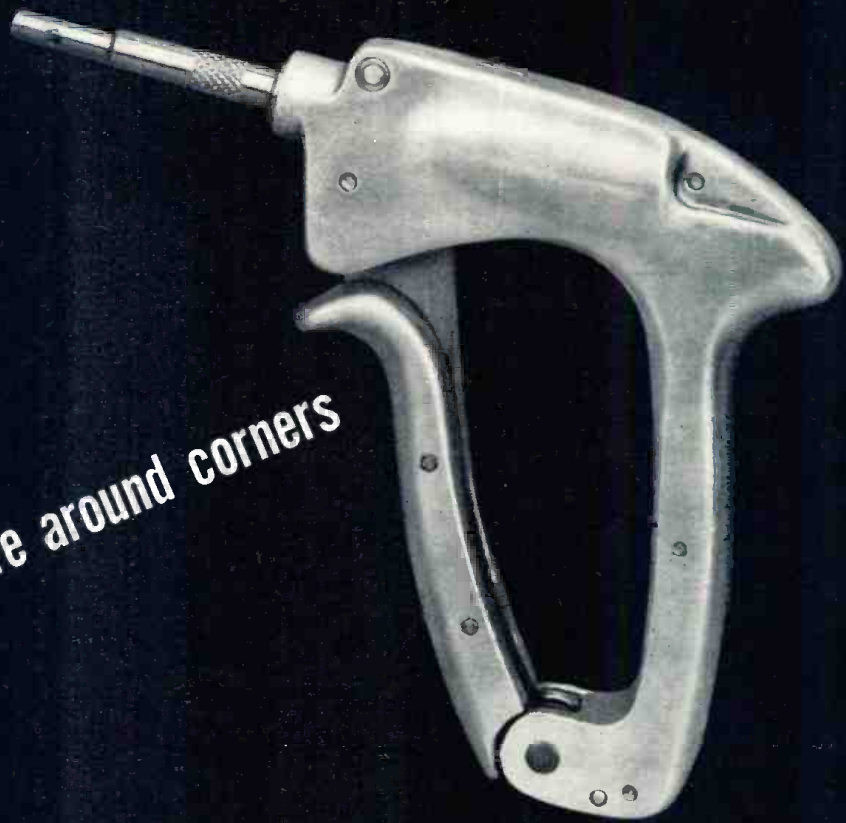

Bell Telephone Company craftsman wraps a wire to complete a connection. Wire is inserted into the nozzle and a rotating spindle whips it around terminals.

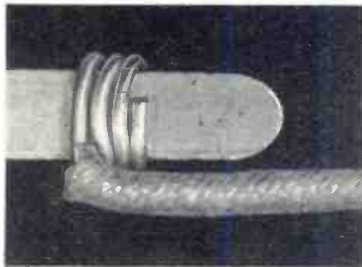

Close-up of connection made with new tool—neat, tight windings.

IT DOESN'T take long to wrap a wire around a terminal and snip off the end. But *hundreds of millions* of such connections are being made each year to keep up with America's growing demand for telephone service.

Now this job is done much more efficiently with a new wire wrapping tool invented at Bell Telephone Laboratories. This "gun" whirls wire tightly around terminals before solder is applied. The connection is better and there is no excess wire to be clipped off—perhaps to drop among a maze of connections and cause trouble later.

The new tool is being developed in different forms for specialized uses. The hand-operated wrapper in the illustration is for the telephone man's tool kit. Power-driven wrappers developed by Western Electric, manufacturing unit of the Bell System, are speeding the production of telephone equipment. The gun's small nozzle reaches where fingers couldn't—a big advantage these days when efforts are being made to produce telephone system parts smaller as well as better.

Bell Telephone Laboratories scientists devise many special tools that help your telephone system to keep pace with service demands economically—keeping your telephone service one of today's best bargains.

## BELL TELEPHONE LABORATORIES

WORKING CONTINUALLY TO KEEP YOUR TELEPHONE SERVICE BIG IN VALUE AND LOW IN COST





Play This  
Winning Combination  
OF

# TV PROFIT MAKERS

50-STATIONS-50



**MODEL HIR TENNA-ROTOR** is the only fully automatic rotator. Just set it and forget it. Your antenna turns to the proper position and stops. North—East—South—West—direction indicator dial shows exact antenna position at all times. Extremely accurate!

**THIS NEW TV BOOSTER** features one simple control. Automatic on-off switch gives maximum, uniform high gain on all channels—quick to install. An excellent companion item to the Tenna-Rotor. The New Alliance Tenna-Scope!

**NATION-WIDE TV ADVERTISING PRE-SELLS!** Tenna-Rotor is the only TV accessory backed by a powerful, sustained television campaign—national in scope. Alliance Tenna-Rotor offers faster installation with 4-conductor "Zip" cable. Works in any weather. 1-year guarantee. U. L. approved.

**ALLIANCE MANUFACTURING COMPANY • Alliance, Ohio**

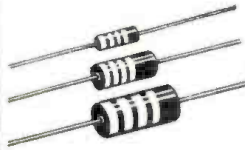

### LITTLE DEVIL COMPOSITION RESISTORS

Resistance and wattage are clearly marked on every one of these tiny, rugged insulated composition resistors. Three sizes: 1/2, 1 and 2-watt in all RMA resistances. Tolerance  $\pm 5\%$  and  $\pm 10\%$ .



### CLOSE CONTROL RHEOSTATS

Insure permanently smooth, close control. Widely used in industry. All ceramic, vitreous enameled; 25, 50, 75, 100, 150, 225, 300, 500, 750, and 1000-watt sizes.



### DUMMY ANTENNA RESISTORS

For loading transmitters or other r.f. sources. New, rugged, vitreous-enameled units are practically non-reactive within their recommended frequency range. 100 And 250-watt sizes, 52 to 600 ohms,  $\pm 5\%$ .

### TYPE AB POTENTIOMETER

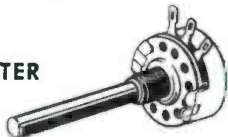

It's quiet! This Type AB Potentiometer has a resistance unit that's solid molded. As a result, the noise level often becomes less with use. Has a 2-watt rating, good safety factor.



### BROWN DEVIL WIREWOUND RESISTORS

Dependable vitreous-enameled units, in a size small enough to fit most installations. Easily mounted by 1 1/2" tinned wire leads. Three sizes: 5, 10, and 20 watts. Tolerance  $\pm 10\%$ .



### DIVIDOHM ADJUSTABLE RESISTORS

These wirewound resistors, with one or more adjustable lugs, provide a convenient means of obtaining odd resistance values. Stock units made in 10, 25, 50, 75, 100, 160, and 200-watt sizes, in many resistance values.

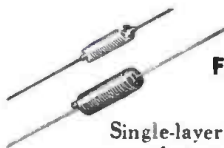

### RADIO FREQUENCY CHOKES

Single-layer wound on low power-factor steatite or bakelite cores, with moistureproof coating. Seven stock sizes for all frequencies, 3 to 520 mc. Two units rated 600 ma, others rated 1000 ma.

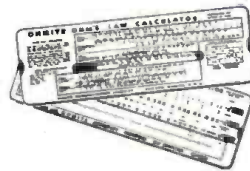

### OHM'S LAW CALCULATOR

Favorite of engineers everywhere! Solves Ohm's Law problems with one setting of the slide. Also has parallel resistance and slide rule scales.

*If it's made by*

# OHMITE

*IT'S DEPENDABLE!*



To countless thousands of technical men all over the world—engineers, designers, and servicemen—the name OHMITE has become synonymous with *dependability*. There is good reason for this overwhelming opinion. Every OHMITE product is carefully designed and constructed to give *extra* performance and long life under severe service conditions. When you need dependable resistance components, play safe and specify OHMITE.

Write FOR STOCK CATALOG



OHMITE MANUFACTURING CO., 4885 Flournoy St., Chicago 44, Ill.

*Be Right with*

# OHMITE

RHEOSTATS  
RESISTORS  
TAP SWITCHES



# "OUR CALL-BACK EXPENSE SCARED US!"



**"Customers' sets kept giving us trouble. That was before we standardized on quality tubes . . . G-E tubes!"**

*Says*

MIKE FILDERMAN, *Vice-President*  
Phillips Radio Company  
2012 Shannon Place, S. E.  
Washington, D. C.

"Today we don't worry, as we did once, about call-back expense endangering profits. Quality tubes, which we use 100 percent, have done away with our most common cause of receiver trouble—tube failures. When our men finish one service job, they can go on to another knowing it's unlikely the first customer will ask for a return visit. Believe me, that saves plenty when you're servicing TV sets on yearly contract—and Phillips has about 15,000 contracts in the Washington, D. C., area . . . Quality and G-E mean the same thing to us! We feature G-E tubes; we find they keep our call-backs down, our men productive, our profits up."

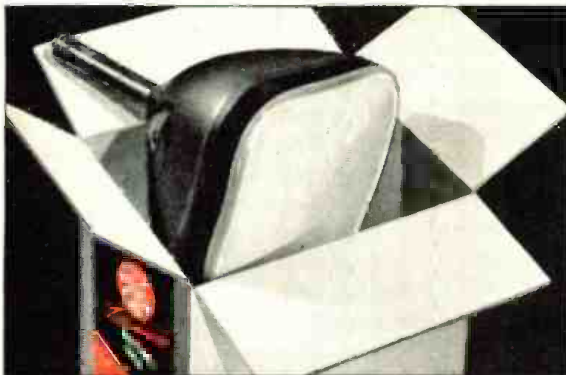

It's a habit with customers, to ask to see the G-E label on tube cartons . . . so Phillips Radio and other service dealers have discovered. No name excels General Electric in public acceptance—means more quality-wise, builds greater user confidence.



Every G-E picture tube is carefully tested for electrical and screen characteristics. Here brightness is being measured, and the screen area inspected for any blemishes. Many other tests follow. G-E tubes are pre-checked for superior performance!

FOR QUALITY TUBES TO CUT DOWN YOUR CALL-BACKS, SEE YOUR G-E TUBE DISTRIBUTOR!

GENERAL  ELECTRIC

101-KAS

**EICO KITS**  
and INSTRUMENTS



**320K S.G. GEN. KIT** \$19.95  
Wired \$29.95



**New 950K COND.-RES. COMP. BRIDGE KIT** \$19.95  
Wired \$26.95



**New 1040K BATTERY ELMA. K.T.** \$25.95  
Wired \$34.95



**51K VOM KIT** \$14.55  
Wired \$17.95

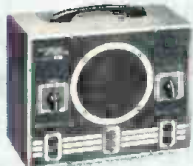

**145K SIG. TRACER KIT** \$19.95  
Wired \$28.95

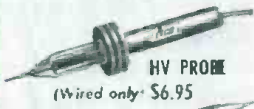

**HV PROBE**  
(Wired only) \$6.95



**RF PROBE KIT** \$3.75  
Wired \$5.95



**C-5 SMC CRYSTAL**  
\$3.95

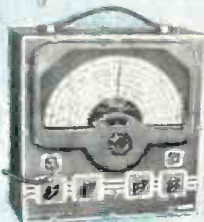

**New 315K DELUXE SIG. GEN. KIT** \$39.95  
Wired \$49.95

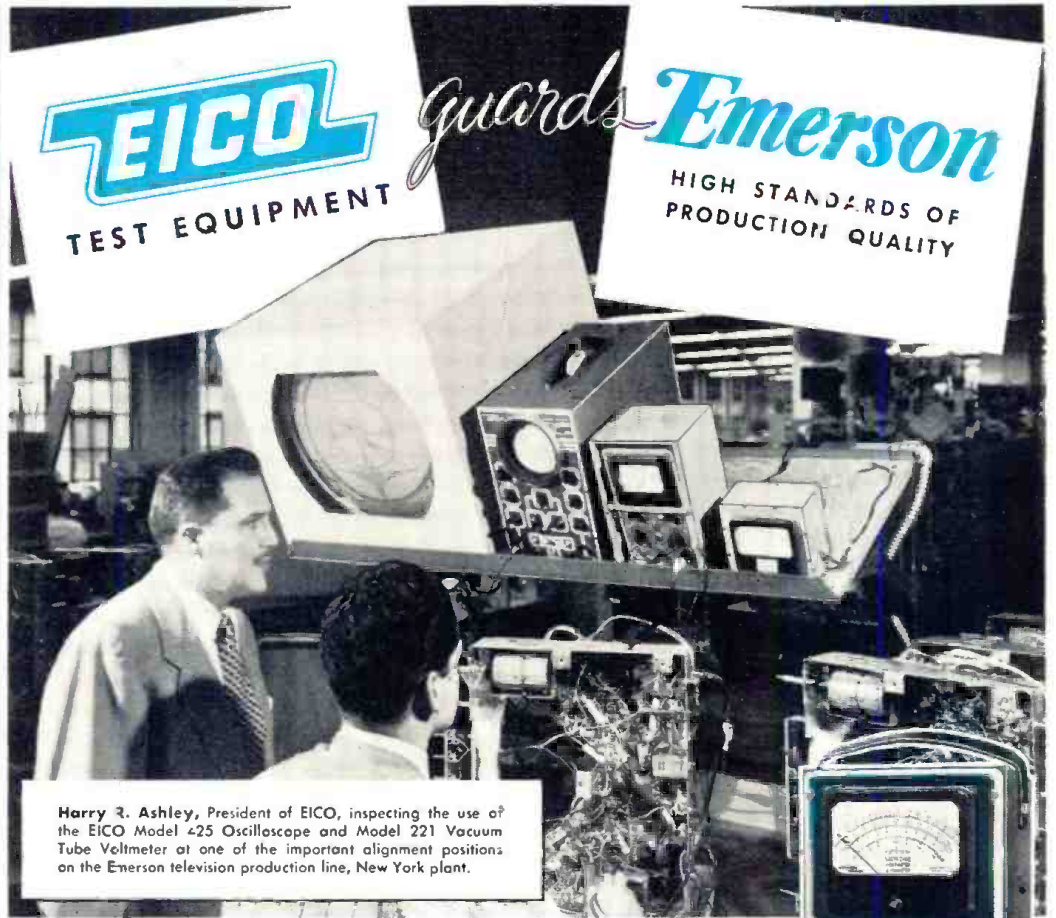

**For Laboratory Precision at Lowest Cost—the Leaders Look to EICO!**

FOR electronics test equipment, there's no tougher proving ground than the factories where TV sets are made. There's where the pace is fastest, precision requirements the highest, costs the tightest—and day-after-day dependability an absolute *must*.

In both the giant New York and New Jersey television plants of the Emerson Radio & Phonograph Corporation — at the many critical constant-duty testing positions along the production line—EICO instruments stand guard. For Emerson has found that for speed, accuracy and trustworthiness, at lowest cost, EICO instruments always deliver the fullest measure of value.

From coast to coast, in one leading TV factory after another, this is the experience—*this is the proof of EICO superiority*—that is repeated again and again. The top-flight TV set makers have discovered—and over 70,000 servicemen have learned—that for the industry's greatest instrument values, at the industry's lowest costs—it's EICO!

Be sure you look at the EICO line before you buy any higher-priced equipment! Each EICO product is jam-packed with unbelievable value. YOU be the judge—compare EICO at your local jobber today—and SAVE! Write NOW for free newest Catalog 5-R.

**FOLLOW THE LEADERS . . .**

**INSIST ON EICO!**



**New 625K TUBE TESTER KIT** \$34.95  
Wired \$49.95



**360K SWEEP GEN. KIT** \$34.95  
Wired \$49.95



**New 221K VTM KIT** \$25.95  
Wired \$49.95



**New 425K 5" SCOPE KIT** \$44.95  
Wired \$79.95



**ELECTRONIC INSTRUMENT CO., Inc.**  
276 NEWPORT STREET, BROOKLYN 12, NEW YORK.

© 1958, Electronic Instrument Co., Inc.

Prices: 5% higher on West Coast. Due to unsettled conditions, prices and specifications are subject to change without notice.

# NAVAL RESERVE Offers New Electronic Training OPPORTUNITIES

By  
**COMMANDER  
E. L. BATTEY**

Assistant Naval Reserve Liaison Officer  
Naval Communications Division



T. C. Kuberski and W. G. Dewell inspect an electronic depth finder at a Naval and Marine Corps Reserve Training Center in Texas.

**Thousands of men in over 800 communities are acquiring new radio skills under the Navy's reorganized Reserve training setup.**

**T**HERE are no raised eyebrows or questioning glances when a group of sailors enters the County Jail at Angleton, Texas every Tuesday night. The citizens of that southern Texas city realize that in this case "stone walls do not a prison make." Naval Reserve Electronics Platoon 8-30 has its quarters in the County Jail and the sailors are gathering to attend the weekly instructional period.

Like the group in Angleton, communications and electronics enthusiasts in some 800 cities and towns throughout the United States assemble each week to receive training as members of the Naval Reserve. They don't all meet in jails, of course. A large percentage use the facilities of Naval Reserve Training Centers. In areas where training centers are not available, local civic authorities and private citizens have cooperated in providing meeting places, under permit or lease arrangements with the Navy.

Procurement of suitable quarters for the electronics and communication equipment supplies has been a problem in this era of housing shortages. Quarters used by electronics units, apart from training centers, are designated Naval Reserve Electronics Facilities or Naval Reserve Electronics Stations, depending on the size of the installation and the number of personnel to be trained. Facilities and Stations are found at colleges, universities, elementary schools, high schools, city halls, fire houses, post offices, police stations, federal buildings, airports, hospitals, and in a variety of private structures, including almost everything from hardware stores to bank buildings, and even a casket factory.

The purpose of the Naval Reserve is to provide a force of qualified officers and enlisted personnel who are avail-

able for mobilization in the event of a national emergency. The Naval Reserve Electronics Program is designed to meet this requirement in the case of operational and technical electronics personnel. Inaugurated in 1946, and reorganized in 1950, the Electronics Program includes one-third of all personnel in Organized Reserve units at Naval Reserve Training Centers, in addition to the many hundreds of persons associated with Companies and Platoons at Naval Reserve Electronics Facilities and Stations. The Electronics Program is the most extensive single program in the postwar Naval Reserve. The prewar counterpart of the Electronics Program was the Naval Communication Reserve, organized in 1925. The Communication Reserve was primarily a training ground for "communicators"—radiomen, signalmen, and communication officers. Instruction in radio theory and equipment was limited. There were no Electronics Technicians in the Navy in the days of the Communication Reserve. The war-born impetus accorded to the field of electronics has been recognized realistically in the new Naval Reserve by increased emphasis on training in both the operational and technical phases of electronics equipment.

#### "Electronics" Defined

The term "electronics" as used in the Naval Reserve Electronics Program is an all-inclusive term covering the many aspects of both technical electronics (maintenance and repair of equipment) and operational electronics (use of equipment). Persons in this program are called "electronics personnel," whether in training as electronics technicians or as radiomen. The Electronics Program, of course, embraces many additional ratings, as for example, Radarman, Sonarman, Quartermaster, Fire Control Technician, and Interior Communication Electrician. Officers associated with Electronics units are for the most part specialists interested in one or more of the broad fields of

communications, technical electronics, combat information center, or anti-submarine warfare.

### Organization

Electronics personnel is assigned to Organized Surface and Submarine Divisions of the Naval Reserve for training, utilizing facilities installed for this purpose at the Naval Reserve Training Centers. One or more of the Divisions training at each Training Center has electronics personnel assigned. In addition, electronics personnel is assigned to Organized Electronics Companies, Volunteer



One view of the Electronics Laboratory at the Naval Reserve Training Center in Charleston, South Carolina. Commander V. H. Conradt-Eberlin, district reserve electronics program officer; Lt. Commander E. E. Stephens, inspector-instructor; and C. J. Walker, radioman 2nd class, watch as Colon Baxley works on a chassis in lab.



Antenna atop the Printcraft Bldg. in Washington, home of Naval Reserve Electronics Companies W1 and W8 and amateur station W3PZA. J. M. Becker, chief radioman, USN, and Allan R. Richter, W4PHL, of the Red Cross consult on transmitting problems.

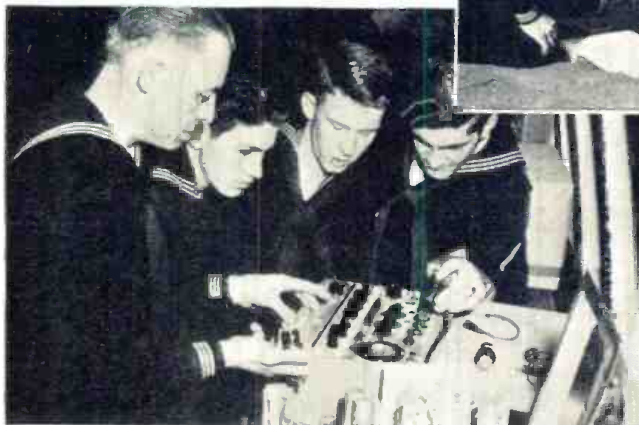

Members of the Organized Surface Division 8-73 at the Naval and Marine Corps Reserve Training Center in Corpus Christi, Texas assist in the conversion of an Army radar unit to a hurricane warning radar unit. This instrument, which is the property of the A & I College in Kingsville, Texas, is being maintained by the Central Power and Light Company and is in operation at the Clift Maus Airport in Corpus Christi, Texas.



F. A. Liberte gets some pointers from Chief Electronics Technician Willis L. Smith on troubleshooting a radio transmitter unit.

← Electronics Technician 2nd Class E. A. Brule demonstrates the proper use of a tube checker to naval electronic technicians.

Electronics Companies, and Volunteer Electronics Platoons. Except for the provision that Organized Companies must meet special personnel requirements and the fact that their members receive drill pay, there is no essential difference between an Organized Company and a Volunteer Company. Each is usually quartered at a Naval Reserve Electronics Facility and the available equipment is utilized equally by both. Volunteer Electronics Platoons, whose personnel allowance is smaller than that authorized for Companies, utilize the facilities of Naval Reserve Electronics Stations. Stations differ from Facilities only in space requirements and amount of equipment furnished. When Volunteer Companies and Platoons are organized in the immediate vicinity of a training center, they use the training center facilities. Organized Companies are not authorized in locations where Organized Surface, Submarine, or Air units are established.

### Widespread Facilities

There are 315 Naval Reserve Training Centers now equipped and operating. Quotas assigned to Naval Districts provide for 500 Naval Reserve Electronics Facilities and 750 Naval Reserve Electronics Stations. Actual establishment is effected as training needs dictate. Certain minimum personnel requirements govern the activation of Companies and Platoons, for which Facilities and Stations are furnished. Approximately 500 Facilities and Stations have been established to date.

### Equipment

Each of the Naval Reserve Training Centers has a complete electronics installation, which includes an electronics laboratory, complete with test and measurement instruments, and radio, radar and sonar equipment. Each Electronics Facility and Station has a similar set-up, but on a scale in keeping with the smaller number of personnel to

be trained. In addition, each Training Center, Facility, and Station has an operative radio station.

The standard equipment allowance lists include quantities of electronics equipment, completely operable units, as well as component parts for original construction projects. Much modern shipboard equipment is available for realistic training.

The Navy has made a large dollars-and-cents' investment in the training program for Naval Reserve electronics personnel. Actually, the program only starts with the equipment and facilities. What really makes it tick is the personnel, both the members of individual units, and the supporting personnel within the Naval Districts and in the Navy Department in Washington. All officers of the Naval Establishment perform the same duties for the Naval Reserve as they perform for the Regular Navy. To provide further support, the Navy retains on active duty a limited number of Naval Reserve officers and men in billets concerned solely with the administration and training of the Naval Reserve.

### Administration

The Chief of Naval Personnel has management control over the organization and training of the Naval Reserve Electronics Program. Commandants of Naval Districts effect administration at district level. Since training is the basic function of the Naval Reserve, the District Director of Training has primary cognizance of the program. Assigned to the office of each Director of Training is a Naval Reserve officer who is responsible for the implementation of the Electronics Program within the district. He is known as the District Reserve Electronics Program Officer (DREPO). Most DREPO's and their assistants are both former members of the prewar Naval Communication Reserve and licensed radio amateurs. All are veterans of World War II. They bring to the Electronics Program many years of experience plus a practical knowledge and understanding of Reserve matters. Working with the DREPO is a Reserve Operational Communication Officer, who is thoroughly familiar with the District Reserve Communication Network and other aspects of training in operational communications. Also assigned to the Director of Training are officers who work on the technical electronics, Combat Information Center, and Anti-Submarine Warfare phases of the Program.

### Training

Training of electronics personnel in the Naval Reserve is of two general types, individual and team. Each individual is trained in the skills required in his specialty and in the application of those skills while functioning as a member of an integrated operational team. The Chief of Naval

Personnel provides curricula for use in the training of each electronics rating and furnishes study and instruction material, including training aids, developed to support the curricula. Correspondence courses in a wide range of general and specialized subjects also are made available to both officers and enlisted personnel for home study.

Team training is associated with three principal operational electronics fields: Communications, Combat Information Center, and Anti-Submarine Warfare. In providing for team training, the Chief of Naval Personnel receives the guidance and assistance of officers within the Office of the Chief of Naval Operations. For example, the Director, Naval Communications, plans for and supervises the Naval Reserve Communication System, which is the principal means for team training in operational communications.

Each Naval District publishes a Naval Reserve Electronics Bulletin for members of the Electronics Program. These Bulletins, which are a valuable adjunct to training, contain timely information on the Electronics Program, items of general interest to Reservists, and useful articles on operational and technical electronics.

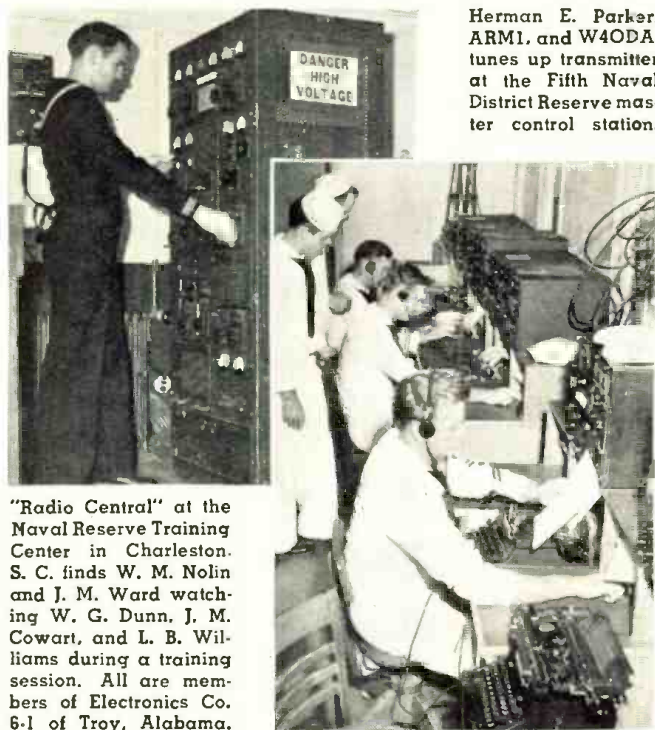

Herman E. Parker, ARMI, and W4ODA, tunes up transmitter at the Fifth Naval District Reserve master control station.

"Radio Central" at the Naval Reserve Training Center in Charleston, S. C. finds W. M. Nolin and J. M. Ward watching W. G. Dunn, J. M. Cowart, and L. B. Williams during a training session. All are members of Electronics Co. 6-1 of Troy, Alabama.

J. L. Fairchild, radioman 2nd class, prepares equipment for code practice transmission from Navy radio station, N1RRF.



Station W5USN, Eighth Naval District Reserve Master Control Station, New Orleans. Left to right are: Commander J. M. McCoy, W5OM; Lt. Commander J. J. Zammit, W5HKP; Chief Radioman F. C. Burt, W5EGX; and Lt. Commander J. P. Foster, W5HNW.





An over-all view of the main radio operating room at the Naval Reserve Training Center located at Albuquerque, New Mex.



Radio code and typewriting class at Pawtucket with Instructors Russell Bates at the key and C. J. St. Andre, WISGC, watching.

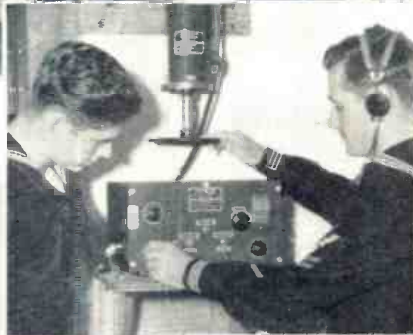

←  
★  
Robert H. Brown, quartermaster (signalman) second class, instructing Houston Carll in the operation of a direction finder at Organized Electronics Company 8-3, Waco, Tex.



The gyro room at the Naval Reserve Training Center in Albuquerque, New Mexico showing the Sperry gyro compass and the repeater panel board. Shown in the photograph standing (from l. to r.) are A. Garcia, Lt. E. W. King, and C. R. Stanello. K. E. Langley, seated at controls, demonstrates unit's operation.

←  
Electronics Technicians C. B. Garcia and J. F. Talerico get practical experience in maintenance and repair of radio receivers.

The Naval Reserve Electronics Program offers an unusual opportunity to the youth who desires to break into the field of electronics. The well equipped laboratories and systematic instruction schedule combine to provide an interesting introduction to the art. The student starts out with basic electricity and works his way through the standard laboratory experiments to a level of knowledge where he may start an intensive study of radio leading to advanced electronics. The curriculum is so designed that an individual can advance according to his capabilities—he progresses from lesson to lesson just as rapidly as he completes each assignment. His progress is limited only by his ability and willingness to devote time to the study. Completion of required training leads to the rating of Electronics Technician in the Naval Reserve. Electronics Technicians not only perform valuable service to the nation in time of emergency by maintaining and repairing Navy electronics equipment, but their services are constantly sought by private industry during peace time. The knowledge gained through association with the Naval Reserve gives a solid foundation for a career in electronics.

### Radio Training Circuits

The Naval Reserve Communication System is composed of radio stations installed at all Training Centers, Electronics Facilities, and Electronics Stations, and the radio stations of certain individual Reservists. In addition, activities and individuals of the Naval Air Reserve, Marine Corps Reserve, and Coast Guard Reserve may participate. In each Naval District, radio stations are assigned to one of several training circuits operating within the District Reserve Communication Network. Each circuit operates on Navy frequencies on a time schedule coinciding with the meeting nights of units served. Thus, personnel receives practical on-the-air training in Navy communication techniques and procedures. The District Network is supervised by the Reserve Operational Communication Officer, with advice and assistance from the District Communication Officer. Training is provided in both manual and automatic methods of communication, including radioteletype where such equipment is installed.

### Radioteletype

Radioteletype installations of the most modern design are being completed in 75 Naval Reserve Training  
(Continued on page 128)



By  
**WILLIAM L. STUART**

Executive Producer  
"Vaughn Monroe TV Show"

# SHOOTING A CLOSE-UP

Close cooperation between cameramen and boom operators is required to produce a clear and interesting close-up picture.

*Some of the "behind the scenes" details that are involved in producing a successful network show.*

**T**HERE has come to be, in this world, a species of man (and in a few instances, woman) who sees light only in terms of four rectangles which are approximately as large as a sheet of writing paper.

Three of these rectangles are the monitors which represent the pictures being shown at the moment in the three cameras which photograph a television show. The fourth represents the picture being sent over the air. The men (or an occasional gal) in question, are television directors, seated deep in a darkened room. Should they ever achieve any degree of suntan, it can only be because the monitors they look at have been miraculously hooked up with an ultra-violet lamp.

To get the feeling of a television control room, it is necessary to describe one. It operates, in most instances, on two levels. On the upper level sits the director: the man who runs the show. Don Appell, our director, who also conceives and stages each program, is flanked by the assistant director on his right, and by the technical supervisor and audio man on his left. On the level below are the technical men and their monitors. Each of the monitors is an "eye" which looks through a camera into the studio. Unwinkingly, they record what each of the three cameras we use is doing at each instant throughout the show. It is the director's duty to choose, at exactly the right instant, which of these three pictures shall be shown to the public, and in what order they shall be shown.

This may sound hit or miss. It is not. It is generally assumed that fifty hours comprises a fairly heavy work week. The work week on the Vaughn Monroe Show consists of about 90 hours in production and direction; and those hours are required to make sure that the three "evil eyes" of the monitors will be showing exactly the pictures wanted at the time they are wanted.

Some twenty-two to twenty-four hours of rehearsal goes into each show. But before that can happen, these things must be done:

(1) The music, selected by polling service camps throughout the country, must be rated.

(2) The pop tunes, as selected, must be fitted into a show.

(3) The numbers must be staged individually.

(4) The scenic designer must develop the setting for the program.

(5) The costumer and property men must shop to costume and dress the show.

(6) The lighting man must determine how the program is going to be lighted.

(7) The musical director and his staff of arrangers must provide orchestrations for all the instruments in the band.

To produce the pictures that appear on the three monitors in the control room, approximately 125 people spend an entire week reading the various elements needed. Having done that, it

*(Continued on page 132)*

One of the television control boards at CBS showing the monitor screens.

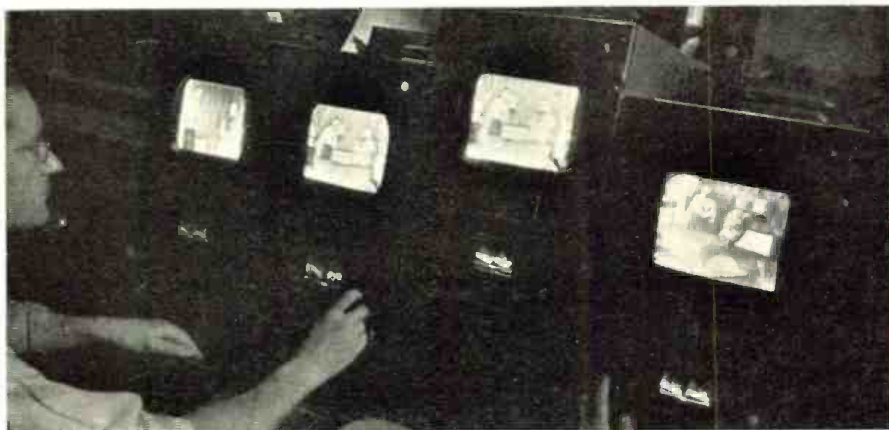

The G-E Model 811 before conversion.



# CONVERTING THE G-E MODEL 811\*

By  
**ROLAND KEMPTON**  
Editor, "Techni-talk"

**Details for converting an early model 10" television receiver to either 12" or 16" operation. Cabinet is big enough to accommodate larger size picture tube.**

**I**N THE past many technicians have avoided small-screen conversion jobs as being time-consuming, low-profit service work. Even in cases where the service dealer was willing to take on such jobs, he made no particular effort to secure a volume of this type of work.

The reasons behind this disinterest ranged from a lack of suitable wood-working tools and skilled help to the lack of "know-how" for making such conversions. If television production is cut to any appreciable extent, technicians will find that requests for conversion jobs will increase and, happily, will afford a fairly painless way of increasing their shop incomes.

Such conversions are now relatively easy because the new rectangular filter-face or aluminized picture tubes can be used without any need to replace the receiver cabinet.

In this and in subsequent issues we will present data for converting several popular receivers, according to instructions drawn up by General Electric engineers. The first receiver to be covered is the General Electric Model

811. This popular console model is shown before conversion in Fig. 1 and after conversion in Fig. 2. The entire receiver should be brought into the shop for this conversion job. The cabi-

*The conversion described in this article is a procedure which produced satisfactory results with respect to a General Electric Model 811. If a conversion is attempted on a similar model of an earlier or later date or on a different model from the same manufacturer, then additional adjustments and steps may be necessary. The changes which were made have not been approved by the manufacturer and may, therefore, invalidate the manufacturer's warranty.*

net is big enough to accommodate either a 12 inch round or a fourteen, sixteen, or seventeen inch rectangular picture tube. Due to the relatively little difference between the "expanded" 12 inch mask and the rectangular 14 inch mask, as shown in Fig. 3, it is both cheaper and easier to convert this particular model to accommodate

\* These conversion notes originally appeared in the October-November 1950 issue of "Techni-talk" published by General Electric Tube Divs.

the 12 inch 12LP4A round tube instead of the 14 inch 14CP4 rectangular tube. This is because the deflection angle of the 14CP4 is 70 degrees whereas the 12LP4A is the same as the 10BP4 tube originally used in this receiver. Whenever a 70 degree picture tube is used to replace a 50 degree picture tube the yoke must be replaced as otherwise neck shadows cannot be eliminated.

It is suggested that the electrical changes be made first and then the cabinet changes whenever a conversion is made on an unfamiliar model. In this way if any difficulty is experienced which might make the conversion impractical, the electrical changes can be returned to their original state. It would be considerably more difficult, however, to return the cabinet to its former condition.

Except for the standard equipment available in most service shops, very few additional tools are required in making conversions and most of these units are needed for the cabinet work. Such "extra" equipment includes a hack saw, a keyhole saw, a half-round bastard file, a wood chisel, plastic wood, a 1/2" hand or electric drill, a hand or electric jig saw, a bottle of dark walnut stain, adhesive rubber cushion (1/2" wide), jig saw blades for plastic, metal, and wood, resistance boxes, capacitance boxes, etc.

## Twelve-Inch Changes

The chassis of the Model 811 should be removed to the service bench and the following changes made.

Disconnect the white lead of the horizontal size control ( $L_{13}$ ) where it connects to pins #4 and #6 of  $V_{13}$ . Tape this end using high voltage insulating tape.

Next short out the series coil of the size control by shunting  $R_{61}$  with a jumper wire.

Now connect a .25  $\mu$ f., 600 v. con-

**RADIO & TELEVISION NEWS**



denser across  $C_{33}$  in the 5V4G cathode circuit.

Finally connect a 500  $\mu\text{fd.}$ , 1000 v. condenser across the secondary of  $T_{17}$  or across the horizontal deflection coils whichever is easier to locate. Assemble and connect the yoke, focus coil, socket, etc. onto the 12LP4A and observe a test pattern. Adjust the horizontal linearity, height, vertical linearity, and focus controls for the best test pattern. If the focus control range is insufficient, short out the 560 ohm resistor ( $R_{70}$ ) which is in series with the focus control,  $R_{72}$ .

If the width is insufficient increase the 500  $\mu\text{fd.}$  capacitance across the horizontal deflection coils and if too wide reduce this same capacitance. The vertical linearity may require some correction which can be made by shunting  $R_{30}$  in the plate circuit of the 6SN7GT vertical sweep generator tube with a 4.7 megohm resistor. The vertical linearity and height controls must then be readjusted.

### Sixteen-Inch Changes

If this receiver is to be converted to use either a 16KP4 or 17BP4A rectangular tube, the following additional components are required. The parts numbers listed are all *G-E* replacement numbers: One RTO-085 horizontal sweep transformer, one RLD-024 deflection yoke, one RLF-038 focus coil, and one RET-003 ion trap magnet.

The following changes should then be made in the horizontal output circuit, as shown in Fig. 5.

Disconnect leads of original sweep output transformer, including filament loop for 1B3GT tube. Mount new transformer on chassis and wire into circuit.

Disconnect the white lead of the horizontal size control ( $L_{18}$ ) where it connects to pins #4 and #6 of  $V_{15}$  and  
(Continued on page 100)

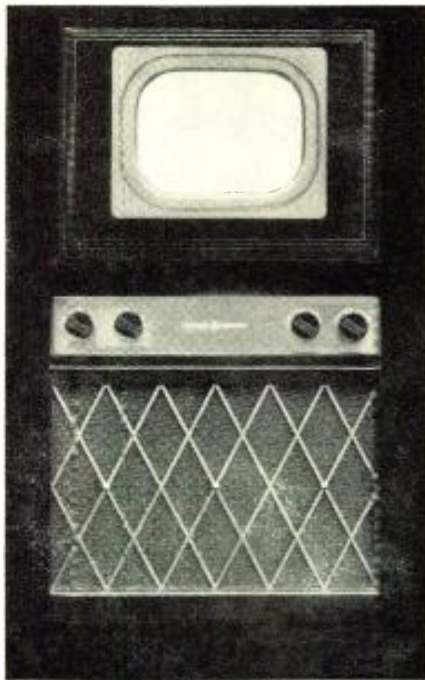

Fig. 1. Front view of the General Electric Model 811 with the original 10" CR tube.

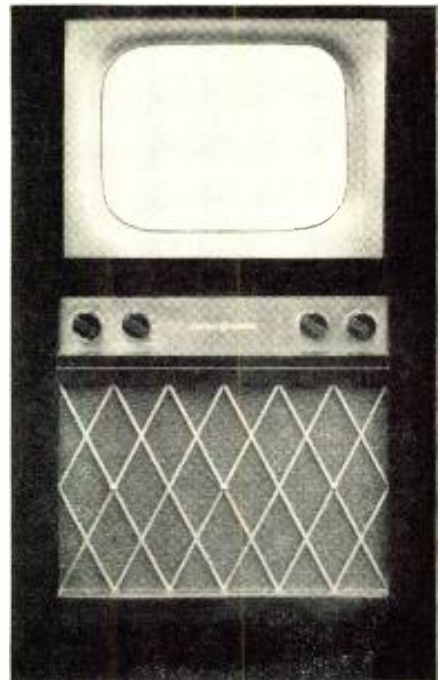

Fig. 2. Same receiver converted to accommodate the 16-inch rectangular picture tube.

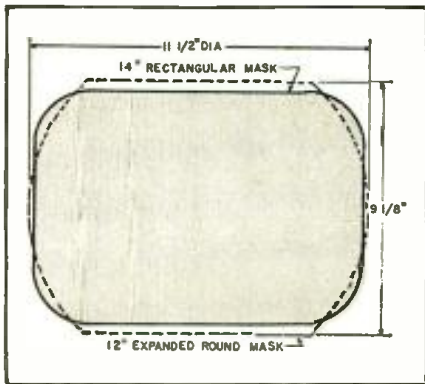

Fig. 3. Area of a 12-inch "expanded" mask compared with a 14-inch rectangular mask.

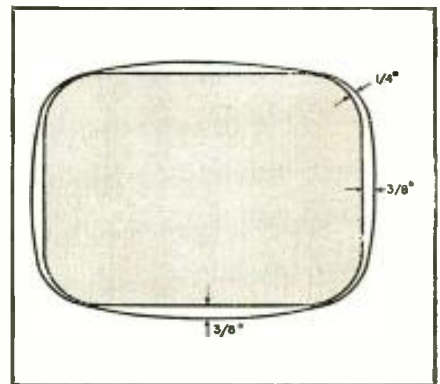
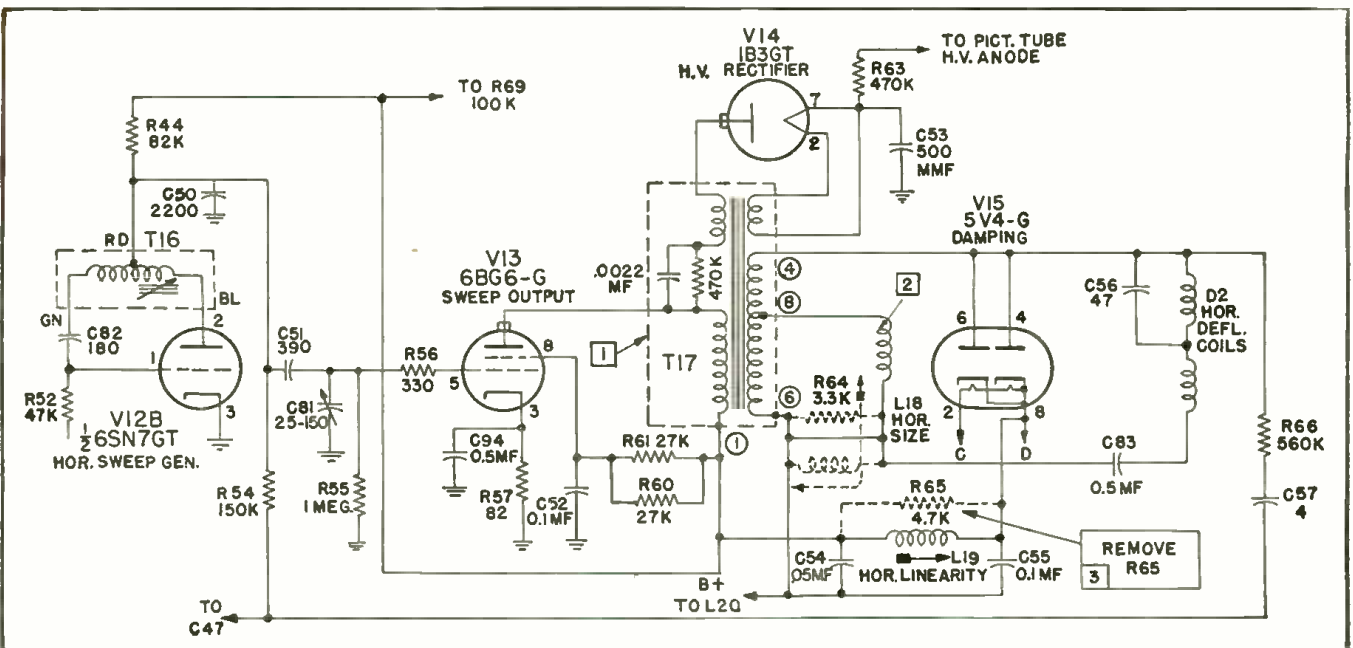

Fig. 4. Useful screen area of 16KP4 picture tube compared with 17BP4A picture tube.

Fig. 5. Horizontal output circuit of the General Electric Model 811 after conversion to use a 16KP4 rectangular picture tube.



# A Civilian DEFENSE STATION

By  
**FRANK HEUBNER**

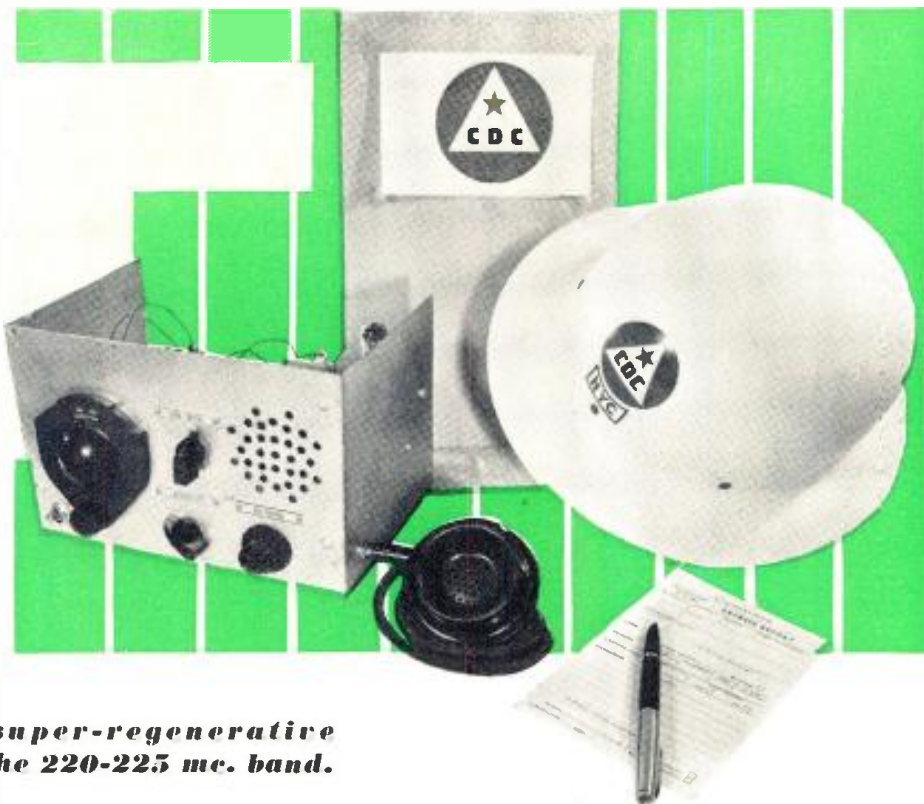

## *Construction details on a super-regenerative type transceiver covering the 220-225 mc. band.*

**S**INCE the Federal Communication Commission has now designated the frequencies for use by Civilian Defense Stations, we can make our final plans accordingly. In these plans we should consider making the most use of the frequencies assigned us so as to cause ourselves the least QRM. The lower frequencies would normally be used for the longer haul city-to-city services, while the higher frequencies with greater frequency allocation should be used for the short haul local services. This type of planning puts the small local incidents on one band and the large incidents, where other city help is required, on a lower frequency band. There is another good reason for this type of planning. The recently approved Technician Class amateur license will open up a new

field for obtaining operators which are urgently needed in Civilian Defense especially as more of the younger hams are drafted. A Technician Class license is only valid on the highest band assigned for Civilian Defense Service, namely, 220 to 225 mc.

In the average small town the maximum distance from any point in town to its centrally located Civilian Defense Center is 5 miles. In the larger cities the local Police Precincts are the Civilian Defense Centers which control their local areas and they are centrally located within 5 miles of any point under their jurisdiction. The problem therefore resolves itself into providing reliable two-way radio transmission for this distance at the minimum expense. The basic station design should be such that it can be used in

**Over-all view of station. Helmet shows comparative size of this compact unit.**

a Civilian Defense Center, hospital, school, fire station, police station, an automobile, or as a "walkie-talkie" field set. It should be so designed that it will work on the regular 115 volt a.c. supply, on a 6 volt automobile battery, or entirely on dry batteries without excessive battery drain.

It is felt that this 220-225 mc. station to be described herein covers the specifications. The equipment is small (6" x 6" x 9") and if placed in a cabinet is readily portable. Tests were conducted on this station in Glen Ridge, N. J. by the Civilian Defense Radio Group. The tests proved so satisfactory that they are now planning five more of these stations to equip a hospital, three schools, and a police headquarters. When additional funds become available a second transmitter and receiver for the Control Center will be installed on the 145.5 mc. band. This will permit communications with the New Jersey State Control and other mutual aid cities.

The basic design of the station is not new. It consists of a modulated oscillator as the transmitter and a superregenerative receiver. The audio system of the receiver is also used as the modulator for economic reasons. With a 300 volt power supply the transmitter gives out about 2 watts of carrier. The current drain at this voltage is 70 ma. for transmitting and 39 ma. for receiving. For portable use with 135 volts of dry batteries the drain is reduced to 17 ma. for transmitting and 13 ma. for receiving. With either of these voltages transmission over 5 miles can be made without any

**Rear view of transceiver. A single button carbon type microphone is used.**

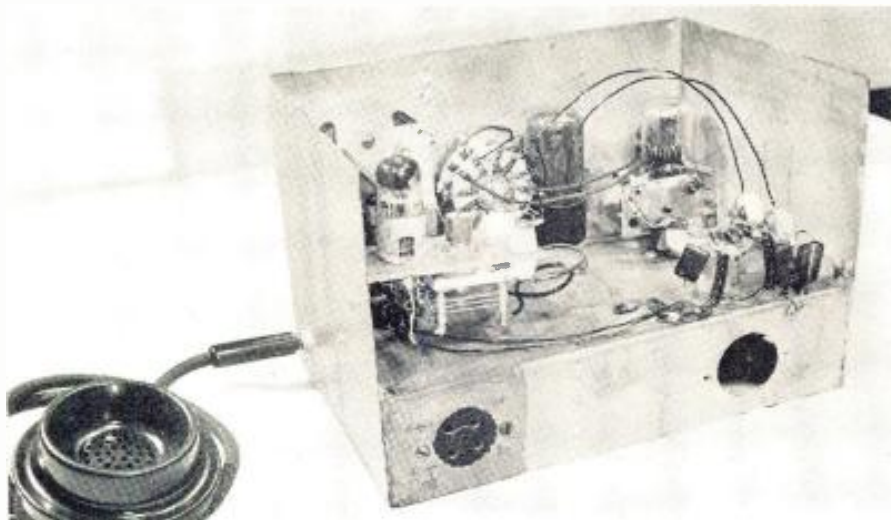

difficulty. Radiation trouble from the superregenerative receiver has been held to the minimum by the use of an acorn 955 tube which, if in good condition, requires only 15 to 20 volts of "B" voltage for proper operation. On nearby stations the antenna coupling may be made very loose which reduces the radiation still more.

This station is not difficult to build and get into operation. Most of the constructional details are apparent from the photographs. The model shown was built from galvanized sheet iron by bending the two sides and front panel from one sheet 6" x 21" long. A 2" high chassis was bent from another sheet and soldered in place. A standard aluminum chassis 2" x 7" x 9" would be just as good. In the front view photograph the receiver tuning dial is on the left, with the "Send-Receive" switch in the center and the regeneration control below it. On the extreme upper right is the PM speaker with the gain control directly under it. The "On-Off" toggle switch in the lower left hand corner may be used to turn on the 115 volt power supply. On the left hand side the two feedthrough insulators are for connecting the antenna. The microphone jack is installed on the lower right hand side of the chassis. The microphone used is a single button carbon type, known in the surplus market as an F1 unit.

In the photograph of the the rear view, the transmitter is on the left hand side in the rear. It was constructed on a small angle piece of aluminum 3/16" thick which is fastened to the side. The 6J6 socket should be mounted adjacent to the butterfly condenser so that the two plate connections will be as short as possible. The 955 detector with its associated coil and condenser are shown at the right rear. A lucite or bakelite 1/4" diameter shaft with a flexible coupling connects the condenser rotor with the front panel dial. On both sides of this shaft adjacent to the front panel are the audio and modulator tubes 6J5 and 6V6. The variable condenser used here was

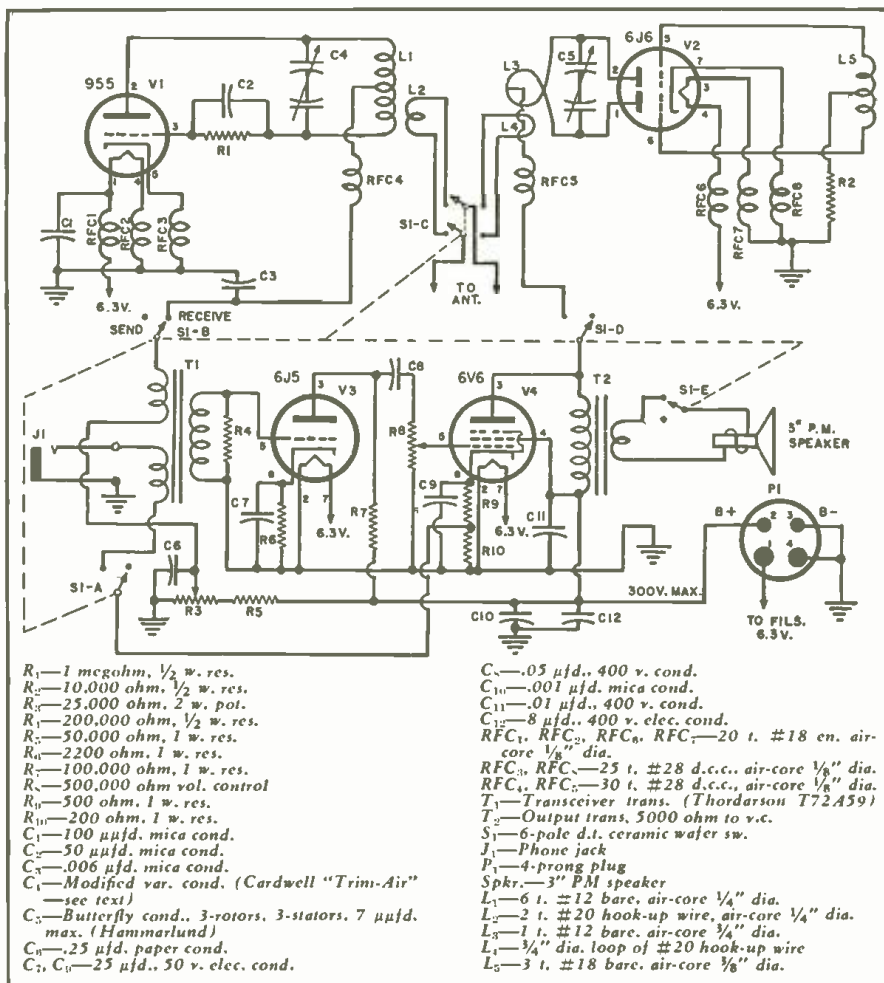

Complete circuit diagram of transceiver. Coils and chokes must be hand wound.

a Cardwell. The stator plate on this model can be removed by loosening the two nuts. This plate is then sawed through the middle between the two mounting holes. The condenser is then reassembled using one post for the grid end and the other post as the plate end of the tank coil. The rotor should be free and not grounded. About 1/16" spacing should be used between the rotor and stator. If this gives insufficient bandsread change the distance

to 3/32". The socket in the rear of the chassis is for connecting the 6.3 volt filament and 300 volt power supply voltages.

The underneath view shows the transceiver transformer mounted toward the rear right. The rest of the resistors and condensers may be mounted at random.

The circuit diagram includes the various coil sizes and these together  
(Continued on page 119)

Bottom view of transceiver. Unit will operate direct from batteries or from either a vibrator or a 115 v. type power supply.

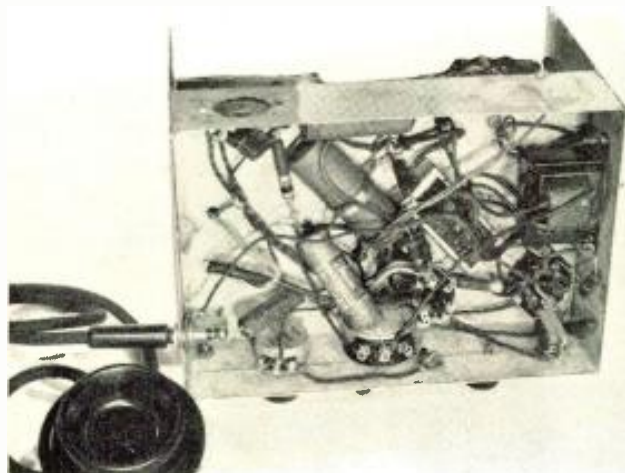

Top view of transceiver. Toggle switch, not included in schematic, shown on front panel is connected in power supply circuit.



# QUALITY AMPLIFIER for TV SOUND

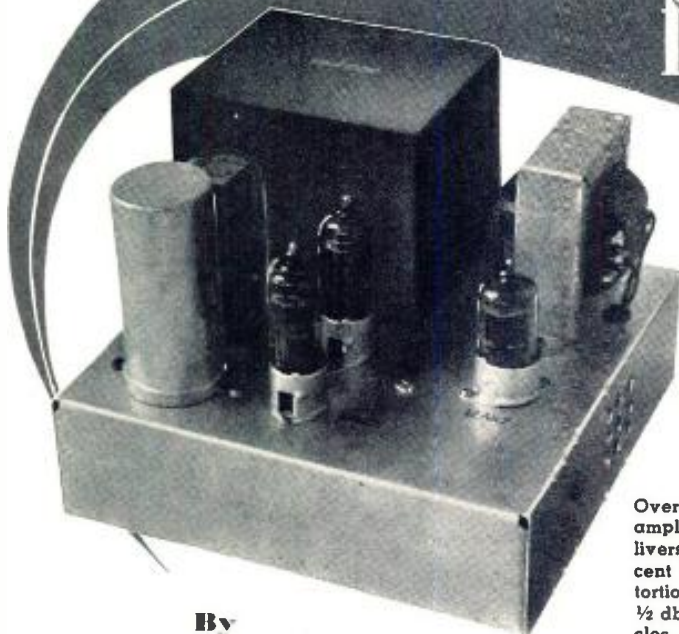

**Construction details on a compact and inexpensive replacement unit which can be built at an approximate cost of \$10.**

Over-all view of the audio amplifier. This unit delivers 3 watts at .5 percent total measured distortion and is flat within 1/2 db. from 20 to 20,000 cycles. Input is just 1 volt.

By  
**LAWRENCE FLEMING**

**T**HE reproduction of a television sound channel requires a little different treatment than other radio and phonograph sources. The difference in the TV sound is that its inherent quality is generally excellent and the background noise level very low, but that listening is done at a comparatively low level. While a good audio amplifier of, say, 12 watts' rating will work fine with a TV receiver, it will be many times larger and more complicated than necessary and may pose a space problem. In TV, sound is subordinate to the picture. Too high a sound level distracts attention from the picture and seems out of balance. At the same time, noisy or distorted sound induces fatigue, and is ruinous to the enjoyment of the show. What is needed is very clean, quiet reproduction with clear, crisp "highs."

It is usually best, to preserve the illusion, to locate the speaker close to the viewing screen even at the ex-

pense of having to use a smaller speaker. In a speaker for this use, freedom from sharp peaks in the response is more important than wide range, and 8-inch units are usually smoother than larger cones. The writer uses a *Western Electric 755A* speaker located in the regular television console, driven by the 3-watt triode amplifier to be described. This amplifier delivers 3 watts at 0.5 per-cent total measured distortion, and measures flat within 1/2 db. from 20 to 20,000 cycles. The input voltage required for 3 watts output is one volt.

This amplifier is pint-sized physically, built on a 7" by 7" chassis without crowding. Standard replacement-type radio parts are used throughout. The cost of all the components should not be much over ten dollars. The output transformer is a *Stancor* type A-3830, a "universal replacement" type rated nominally at twenty watts and weighing two pounds. Used so far

under rating, this unit will deliver 4 watts at 70 cycles and about 2 watts at 40 cycles before core-saturation distortion becomes noticeable.

Actually an amplifier of this sort is so far superior to that built into most radio and TV sets that its incorporation into any ordinary console will make a vast difference in the audio quality. The 3 or 4 watts is more than adequate power for any living room, except perhaps for addicts of ear-splitting volume.

The writer's aim was to make a good self-contained audio unit which would fit into spare cabinet space, and would replace the audio channel originally in the set. The amplifier has its own power supply, so that the only connections required to the receiver are input, speaker, and 117 volts a.c. No tone controls are included, since these properly belong outside the feedback loop and on the tuner chassis, available to the panel. A considerable effort was made to achieve the lowest weight, size, and cost commensurate with the best performance.

Fig. 1 shows the frequency response and Fig. 2 the total harmonic distortion versus output power. In Fig. 1, curve A gives the measured response before the negative feedback was applied. It is down 1 db. at 60 and 8000 cycles, due principally to the output transformer, although some of the high-frequency droop is traceable to the high- $\mu$  triode amplifier stage. Curve B is the response with feedback. Although only 12.5 db. of feedback is used, it flattens out the curve more than adequately. The only departure from a straight line is now the 1.5 db. peak at 40 kc. Above 40 kc. the two curves run together. Both curves were plotted with the same input (.093 volt), so that the difference in db. between the two is the actual amount of feedback existing at that frequency. Thus, at 20 cycles there is 9.5 db. of feedback, and at 40 kc. and above there is none. Through the audible range there is plenty of feedback, since no shunt condensers are used across any stage.

Fig. 1. Frequency response curves for the amplifier, with and without feedback.

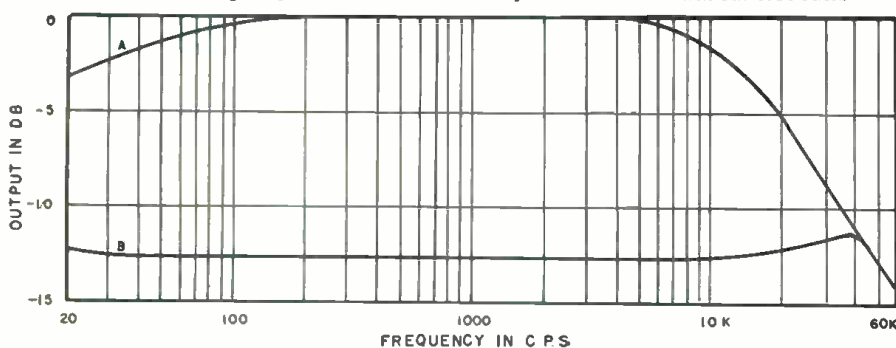

Distortion was measured at 80 and 400 cycles, across the output transformer secondary into a 4-ohm resistive load. The results were the same at both frequencies, and the total harmonic content at various power levels is shown in the curve of Fig. 2. The distortion rises slowly from about 0.2 per-cent at one watt output to half a per-cent at 3 watts. If one were to promote such an amplifier commercially, he might rate it at 4.5 watts, since this is where the 5 per-cent distortion level is reached. However, let us be conservative and call this a 3-watt amplifier, or, if 2.5 per-cent distortion is not too much, a 4-watt job.

The plate input to the power stage is about 14 watts, so that the efficiency at 4 watts output is 28.5 per-cent. This is not bad for class A triodes including the output transformer, and in fact indicates that the insertion loss of the output transformer that was used is unusually low.

A check of distortion was made at 40 cycles and it was found that the output transformer overloaded at 2.5 watts, but that at 2 watts the distortion was only about 1.5 per-cent. This is mainly of academic interest since the speaker used cuts off at 70 cycles. However, to avoid intermodulation troubles from unheard low frequencies, it might be well to provide some low-frequency cut ahead of the input.

#### Damping and Hum

Connecting a 4-ohm resistor across the secondary terminals dropped the voltage 10 per-cent from the open-circuit value. Thus, the output impedance is 0.4 ohm on the 4-ohm tap, and the speaker damping factor is 10.

The hum voltage at the voice terminals measured 1.5 millivolts (about 1/2 microwatt), or 66 db. below 3 watts. While this level is inaudible, it is worth noting that most of this hum is inductive pickup by the output transformer from the power transformer, and that it is well to orient these two components so that their coils are at right angles.

The circuit, shown in Fig. 3, is about as simple and straightforward as can be, but is the result of considerable experimentation. The output stage is a pair of 6AQ5 miniature beam tubes, triode-connected, in push-pull, with 300 volts on the plates. The tube complement is completed by a single high-mu twin triode as the voltage amplifier and phase inverter.

In its use of triodes at comparatively high plate voltage, this circuit may be considered a smallish cousin of the *Williamson* amplifier. It is also based on a very low-distortion 6L6 circuit designed some years ago by the West Coast audio engineer, Dunford Kelly.

A survey of the triode characteristics of various small power tubes showed, rather surprisingly, that the 6V6 was far and away the best. Its miniature counterpart, the 6AQ5, has the same properties. Table 1 gives the pertinent data for these tubes, calculated from published curves and

checked by experiment. Due to their rather high mu (9), the efficiency drops rapidly below about 300 "B" volts. However, the optimum operating conditions involve fairly low plate current (50 mils for two tubes), so that the plate dissipation is well within limits. The screen current in triode connection is only 2 to 2.5 mils, so that there is no danger of the screens overheating.

The tubes are operated about halfway between class A and class AB. The bias resistor for straight class A is 330 ohms, but the decrease in distortion is negligible.

The first stage is half of a 12AX7 high-mu twin triode, operating as a straight voltage amplifier with "contact potential" bias. Regular cathode-resistor bias, bypassed, was found to give hardly any improvement, and the feedback system is more stable with the simpler arrangement. This stage is direct-coupled to the other section of the 12AX7, operating as a split-load phase inverter.

The output transformer is a 20-watt universal replacement type as mentioned before, and is fully adequate for the power level developed by the 6AQ5's. If this amplifier were to be used with a large speaker system with extended low-frequency response, there might be some reason for employing a large high-fidelity type transformer, but for living-room use down to 60 or 70 cycles, such a transformer would be of no advantage at all.

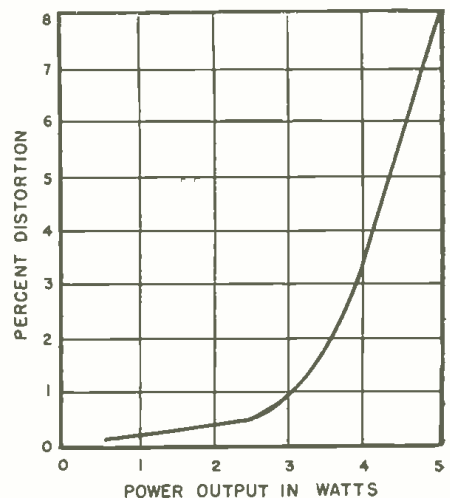
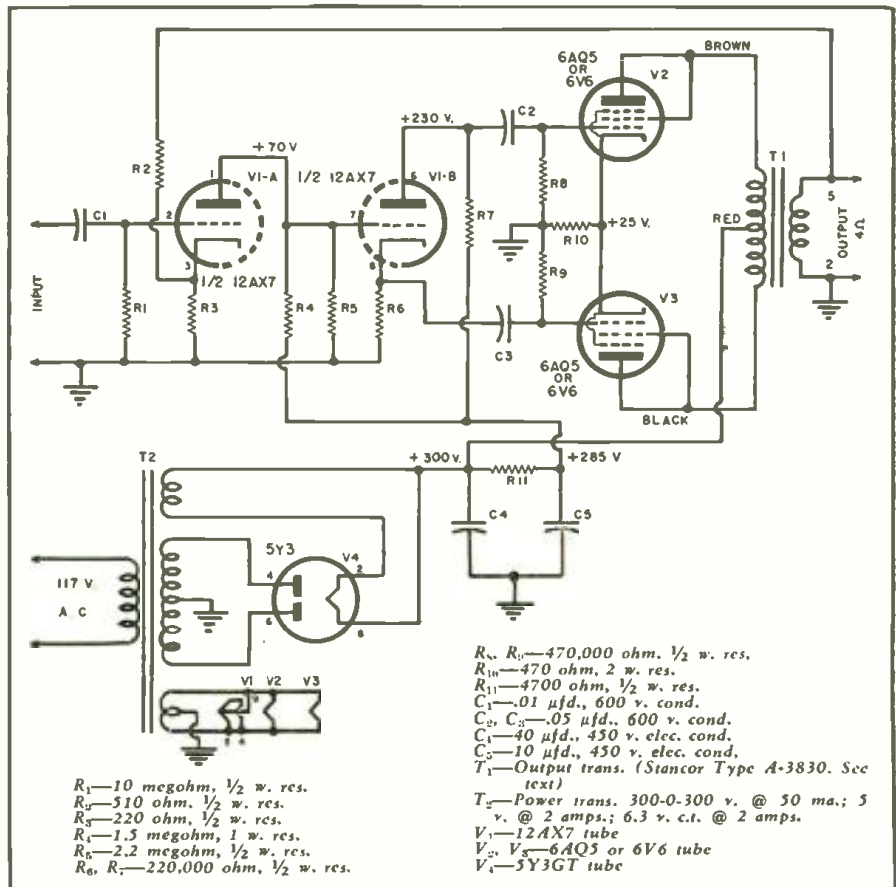

Fig. 2. Harmonic distortion vs. power output.

It is recommended that the transformer specified be used, because the negative feedback is taken from the voice coil winding, and the circuit was designed for stable feedback under all conditions with that particular unit, connected exactly as shown. The connections indicated are correct for any 3.2 to 4 ohm speaker. For an 8 or 15-ohm voice coil, connect to terminals 1 and 5 and ground terminal 1. The impedance match is not critical with triodes.

If a substitution of transformers is made, it is advisable to explore the range from 20 cycles to at least 100 kc. (Continued on page 151)

Fig. 3. Complete circuit diagram and parts list for the television sound amplifier.



# Emergency TEST INSTRUMENT

By  
**FRED A. ORTH**

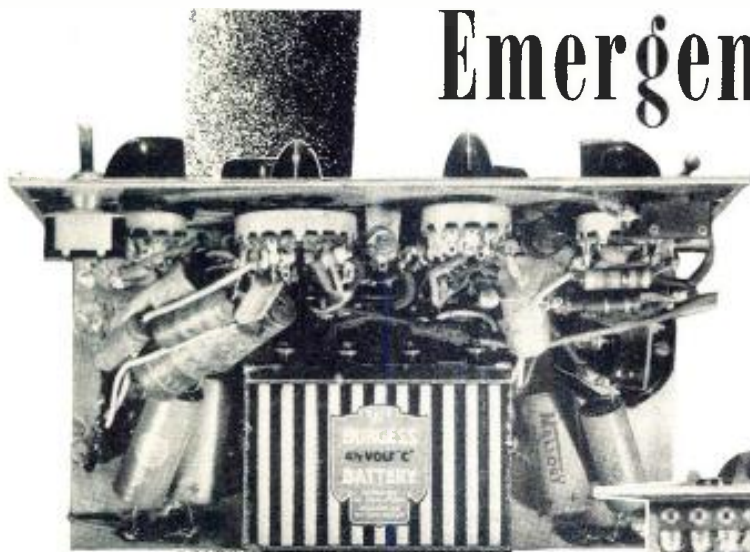

Top and under chassis views of the versatile home-built test unit.

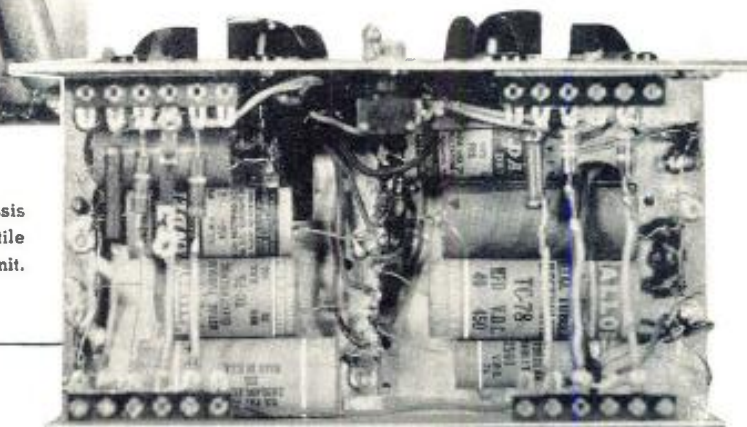

***A handy unit for the busy service shop where an instrument breakdown can mean a financial loss.***

**W**HEN a test instrument "conks out" the service technician is often placed in an unenviable position, especially when he is expected to keep the sets rolling out of his shop.

When such a unit must be returned to the factory for repairs or there is a delay in getting some replacement part, this can often represent a real dollar-and-cents loss to the technician. Having faced just such a problem, the author designed and built "Old Faithful"—a seven-section test instrument to be described in this article.

It should be emphasized that this unit is not a substitute for standard, commercially-built instruments but is merely a standby to be used in conjunction with the technician's remaining test instruments.

Each of the seven sections comprising "Old Faithful" operates independently. This feature increases the flexibility and serviceability of the instrument, a point most technicians will appreciate.

## **Section One**

The first section of the instrument provides a circuit for measuring the leakage of electrolytic condensers at the working voltage of the receiver and is used in conjunction with a d.c. ammeter. It also provides a blocking condenser circuit for tracing audio signals with phones. In addition it may be used as a substitute 5 inch PM

speaker for connection to a receiver's output transformer secondary. For details on the proper procedure for using the instrument in these applications see Table 1.

When measuring electrolytic leakage current it might be well to remember that for condensers of 300 volts or higher the permissible leakage is .5 ma. per  $\mu$ fd.; for 100 to 275 volts the allowable leakage is .2 ma. per  $\mu$ fd.; and for under 100 volts the limit is .1 ma. per  $\mu$ fd. These leakages are maximums and in some circuits these figures will have to be lowered.

To protect the milliammeter against damage because of a shorted condenser one of the following precautions should be taken. (1) Observing polarity, test the electrolytic condenser with an ohmmeter before conducting the leakage test. (2) In case the ohmmeter is the instrument which is out of commission, use the electrolytic quality test as outlined in Section Two. (3) When conducting the leakage test start with the highest meter range and turn the receiver on. Watch the meter and if the current builds up to where the pointer starts reaching for the highest reading on the dial, turn the receiver off promptly as the condenser is shorted and hence defective. If the condenser is not shorted, the meter may be set to a lower range and a reading taken. *Caution.* High voltage is present during the test and all of the customary

precautions which apply in the presence of high voltages should be taken. When the test has been completed disconnect the negative terminal of the milliammeter first.

## **Section Two**

Section Two of the instrument is an r.f.-i.f. signal tracer, an audio signal tracer, provides means for making a high resistance continuity test, serves as a tester for pilot lamps, and serves as a quality checker for electrolytic condensers.

A second audio signal tracer is provided in this section in anticipation of the prior application of the substitute speaker in Section One, in which case the audio signal tracer in Section One would not be available for audio signal tracing.

Since only  $4\frac{1}{2}$  volts are used to store the charge in the condenser for the electrolytic quality test, the test is only recommended for condensers of 150 volts and higher.

## **Section Three**

This section provides resistor substitution facilities by means of nine 1-watt resistors which range in size from 47 ohms to 100 megohms. The section also provides eight substitute condensers, all of which except the lowest capacitance unit are paper, from .00025  $\mu$ fd. to 1  $\mu$ fd., 600 v. Low resistance visual continuity checks can be made by means of a 3.8 v., No. 13 lamp mounted in the center of the panel. This facility is especially convenient when testing for shorts in variable condensers or for testing continuity and shorts in tubes or other low re-

**RADIO & TELEVISION NEWS**

sistance circuits. If this test indicates an open in a resistance circuit, the suspected part should be discarded only if the open is confirmed by the high resistance continuity test described in Section Two.

### Section Four

This section permits the capacity measurement of paper or mica condensers from .001  $\mu$ fd. to 1  $\mu$ fd. when used in conjunction with an a.c. voltmeter. Note that resistances  $R_{12}$  and  $R_{11}$  in the circuit diagram are based on the use of the a.c. voltmeter section of a Simpson Model 260 v-o-m. If other a.c. voltmeters are used with this instrument, the value of resistors  $R_{12}$  and  $R_{13}$  will obviously have to be computed.

When using the Simpson Model 260 with the instrument's .001-.01  $\mu$ fd. setting ( $S_4$  in the  $u$  position) the following voltage readings on the 10 volt a.c. scale will indicate the capacities specified: .6 volt = .001  $\mu$ fd.; 1.1 volts = .002  $\mu$ fd.; 1.5 volts = .003  $\mu$ fd.; 1.9 volts = .004  $\mu$ fd.; 2.5 volts = .005  $\mu$ fd.; 3 volts = .006  $\mu$ fd.; 3.6 volts = .007  $\mu$ fd.; 4 volts = .008  $\mu$ fd.; 4.4 volts = .009  $\mu$ fd.; and 4.8 volts = .01  $\mu$ fd. These values are lettered on the face of the instrument panel, directly beneath Section Four.

With the .01 -.1  $\mu$ fd. setting ( $S_4$  in the  $b$  position), meter readings on the 10 volt a.c. scale conform to the ca-

capacity of the condenser in that if the reading on the v-o-m meter scale is 2 volts the capacity of the unknown condenser is .02  $\mu$ fd. Similarly with the .1-1  $\mu$ fd. setting ( $S_4$  in the  $c$  position) if this reading on the 10 volt a.c. scale is 8 volts the capacity of the condenser is .8  $\mu$ fd.

When starting the test, set the a.c. voltmeter selector switch to a range in excess of line voltage so that if the condenser is shorted the meter will read the line voltage and no damage to the meter will result. If the condenser is shorted, the test voltage should be removed immediately since resistors  $R_{12}$  and  $R_{13}$  will not withstand full line voltage for any length of time.

### Sections Five and Six

Each of these sections provides both a filter section hum check and electrolytic condenser substitution facilities with each section operating independently of the other. Section Five provides condenser substitutes of 4, 8, 12, 16, 20, and 40  $\mu$ fd. while Section Six provides substitutes of 8, 12, 16, 20, 40, and 100  $\mu$ fd. capacity. All of the condensers are rated at 450 volts except the 100  $\mu$ fd. unit which is rated at 25 v.

### Section Seven

This section provides a high frequency buzzer signal generator that generates signals ranging from 0 to over 100 mc. This signal may be in-

jected in any stage of the receiver from the antenna to the speaker.

### Additional Notes

Should your voltmeter be the instrument out of commission, voltages in a receiver may be tested for "presence" by means of a neon lamp which responds to voltages ranging from 90 to 550 either a.c. or d.c.

This emergency test instrument is housed in a metal cabinet measuring 8 x 10 x 4 3/4 inches. The chassis was chosen to fit the cabinet easily. Bakelite jacks provide insulation from the metal panel.

The paper condensers in Section Three are connected with one lead soldered to the switch in order to keep the leads as short as possible. Four of the six electrolytic condensers in each of Sections Five and Six are mounted under the chassis with the remaining two on top of the chassis. The resistors go under the chassis. The speaker is mounted on the inside back of the cabinet which is louvered.

The buzzer is mounted on top of the chassis as is the 3 volt battery. The battery is held in place by terminal strips on each side and by the lower speaker bolts which rest on top of the battery when the chassis is placed in the cabinet. The panel is soldered to the chassis and is finished in black.

In constructing this particular in-  
(Continued on page 90)

Complete circuit diagram and parts list covering the seven-sections of the "emergency" test instrument.

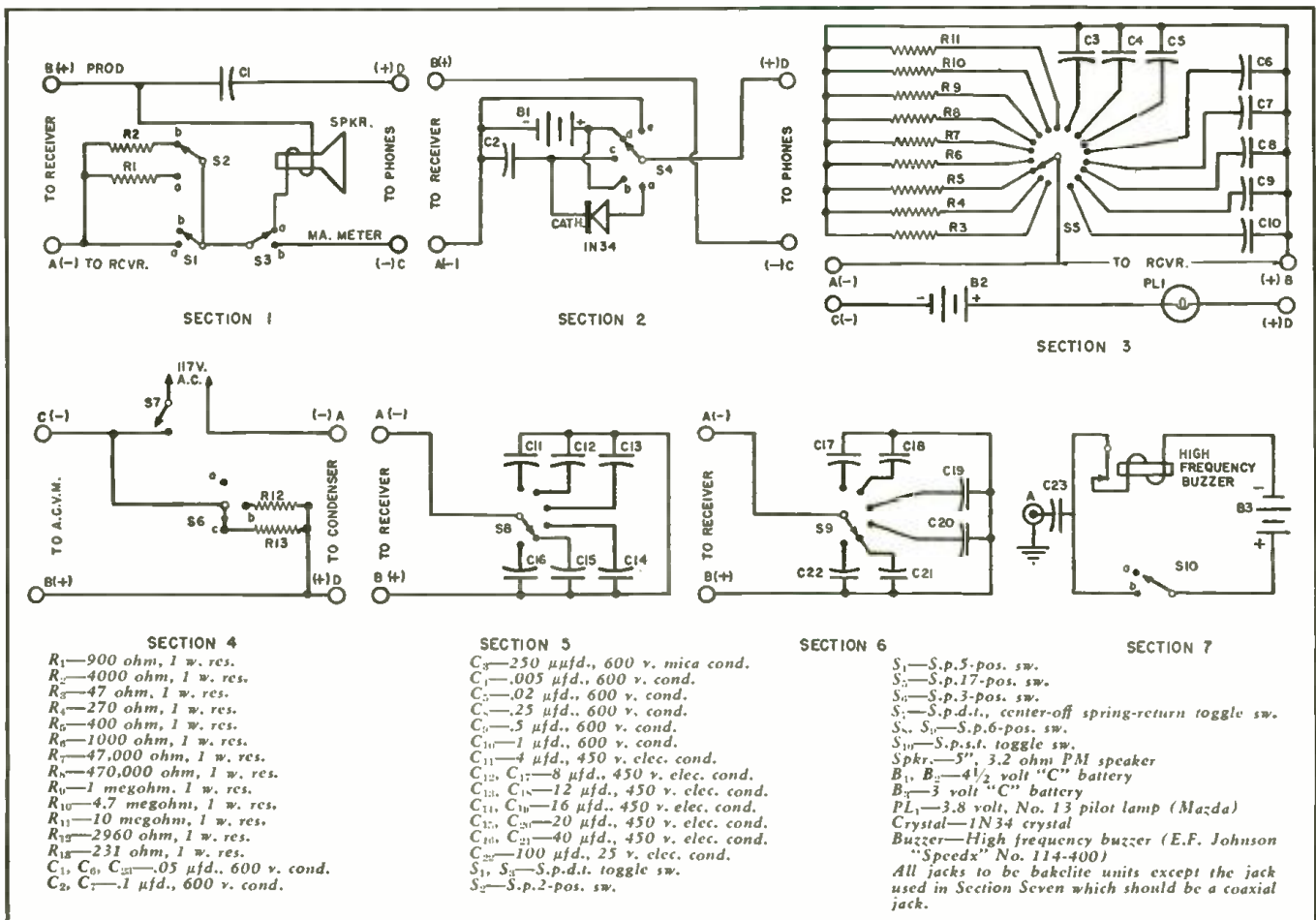

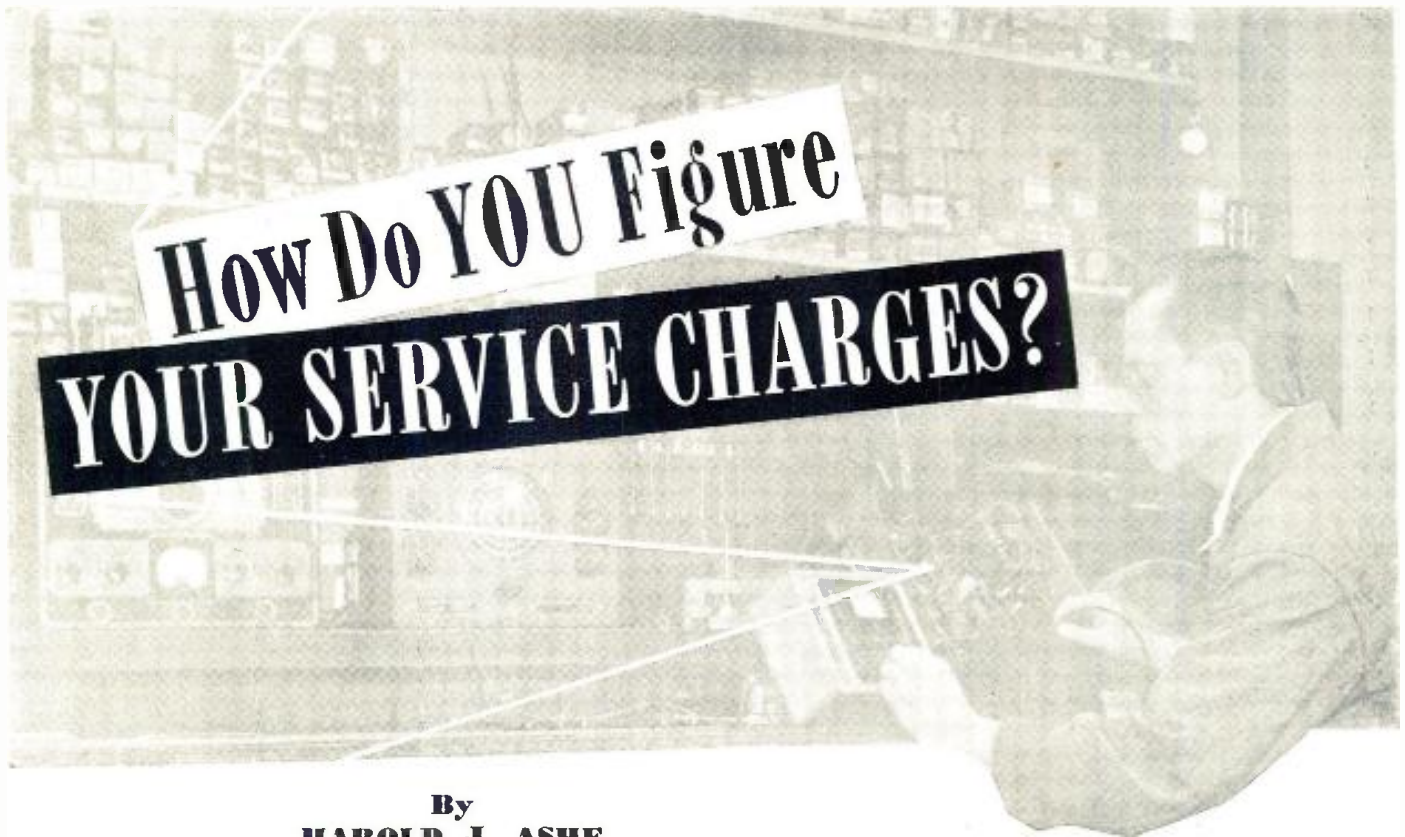

# How Do YOU Figure YOUR SERVICE CHARGES?

By  
**HAROLD J. ASHE**  
Tax Consultant

**Many individually owned and operated service shops underprice competition not because of lower overhead but because many operating expenses are overlooked. Here is a handy check list.**

**W**ITH an increasing number of radio and television technicians setting up shop for themselves, this is as good a time as any to discuss service charges, pricing formulas, and certain business conceptions held by all too many owners of small shops.

Many established service shop owners who have learned the hard way look askance at these newcomers in the trade. This is usually not so much because they resent competition, as such, but because all too often these one-man and small shops represent *unfair* competition.

Old hands in radio and television servicing have long since discovered that there is more, much more, to conducting a successful shop than having

the technical know-how, important as that is. Many established service shop owners criticize their new competition because the latter have smaller overhead, and therefore can successfully scale down their charges.

We'll agree that a disturbing number of small shops do maintain price schedules that are lower than their larger competitors. We disagree, however, that this is because, generally, the one-man and small shops have a pricing advantage of smaller overhead.

The reason that small shops can and do under-price is because they *think* they have lower overhead. Percentage-wise, the typical shop employing only one technician and with the owner also working with tools is likely to have as high an overhead in dollars-per-techni-

cian (including the owner) as does a shop having six or eight men on its payroll.

While these newcomers are making it rough for established service shops whose owners know their costs, they are traveling a rough road themselves, even though they may not immediately be aware of the chuckholes ahead of them.

What, in effect, many of these new shop owners are doing is selling their own skilled labor piecemeal and with the prospect that they will make even less than they'd earn working on salary for another shop.

Not infrequently their prices are determined by the lowest prices quoted by the cheapest shop in the community, rather than a price commensurate with the service performed. Instead of making a charge that will permit a profit they make a charge, determined by the lowest priced shop in town, scale it still lower, and then hope for a profit that never accrues to them.

Or, they may attempt to determine prices by an over-simplified formula in which straight labor time is figured, plus a moderate addition for overhead, and a modest amount for "profit". Usually, this so-called "profit" disappears through the year to satisfy hidden overhead that has not been anticipated. This is service pricing reduced to the ridiculous. It might be amusing except for the fact that thousands of one-man shops, unschooled in costing procedures, employ this pricing formula to their own financial detriment as well as to that of ethical competitors who are trying to maintain

(Continued on page 146)

Table 1. Check list of representative overhead expenses. While the listing is far from all-inclusive, there are few shops which do not spend varying sums for practically all of the items tabulated. Even where the shop owner works out of his own home, certain utility expenses, rent, etc. should be charged to shop overhead.

Rent, light, heat	Salaries of non-productive employees
Telephone	Technicians' wages
Postage	Public liability insurance
Technical books, trade magazines	Property damage
Ledgers, accounting forms	Truck depreciation
Letterheads, stationery supplies	Truck insurance, including liability
Equipment depreciation	Loss of tools, equipment
Advertising	Depreciation of tools, equipment
Fire, casualty insurance	Non-productive supervisory time
Taxes and licenses	Call-backs on complaints
Donations	Unworked time, holidays, etc.
Association dues	Waste and spoilage
Losses from bad accounts	Social security tax (on employees)
Transportation costs	Unemployment insurance tax
Unproductive time (making estimates, etc.)	Workmen's compensation insurance
Business entertainment (if any)	Miscellaneous





Over-all view of transmitter. See schematic diagram for identification of parts.

# A Mobile LOW-POWER 10 METER RIG

By

**HARDIN G. STRATMAN**

*A well-engineered transmitter that can cover 5 to 10 miles using a conventional communications receiver.*

**U**SUALLY when a sudden disaster such as a fire, a flood, or a windstorm occurs, there rarely is a means of communication available to link the scene of action to the broadcasting station over which a reporter might tell an eager and curious listening audience exactly what is happening as it happens. This situation also arises when covering special events such as parades or ball games.

Engineers at the *Gates Radio Co.*, Quincy, Illinois, designed the compact and useful mobile transmitter about to be described for remote broadcast pickup between 26.11 to 26.47 megacycles, a frequency band which effectively eliminates all of the previously mentioned hampering conditions. Since the unit's useful frequency range extends from approximately 25 to 30 megacycles it is easily adaptable for use in the 10 meter amateur band without changing any components.

### Circuit Description

The circuit arrangement of the transmitter is relatively simple. Using a crystal of from 8 to 10 megacycles, the oscillator stage triples in the plate circuit of a 6AG7 tube ( $V_1$ ) and the resulting electrical energy is then injected into the grid circuit of a class C power amplifier stage utilizing a 2E26 beam power amplifier tube ( $V_2$ ) which simplifies the tuning because it eliminates the necessity for neutralizing. The power amplifier stage is plate modulated by a pair of 6L6 tubes ( $V_3, V_4$ ) working in the modulator stage. A pi-network is used in the antenna coupling circuit, a feature which might prove of especial interest to the reader. This pi-section matches the high impedance of the power amplifier tank circuit to the low impedance (approximately 20 to 60 ohms) of the antenna

used while, at the same time, reducing harmonics. Although matching a high impedance to a low impedance reduces the voltage, the current is increased—a very desirable condition in a transmitting antenna.  $C_9$  and  $C_{10}$  connected in series across  $L_2$  form the plate resonant circuit which, of course, should always be tuned to the output frequency being used. The junction of  $C_{10}$  and  $L_2$  is the matching point and since  $C_{10}$  is of greater capacity than  $C_9$  its reactance will obviously be lower than that of  $C_9$ , a factor which will permit it to be tuned to match the characteristic low impedance of the quarter-wave antenna used. This circuit also reduces de-tuning of the power amplifier stage because of the variations in antenna characteristics which occur as the antenna sways or is approached by some object.

A very simple over-modulation circuit is provided in the transmitter. This consists of a quarter-watt neon bulb connected in series with a 250,000 ohm potentiometer ( $R_1$ ) and a 270,000 ohm resistor ( $R_2$ ) between the plate supply of the power amplifier and ground potential. By means of the variable potentiometer, the neon bulb can be made to flash with any value of modulation percentage.

The initial tune-up of the transmitter should be performed as follows: After first removing the plate cap from the 2E26 tube, turn the transmitter on and allow it to warm up. Then check the grid current of  $V_2$  by means of a test meter through the grid current jack ( $J_1$ ) provided on the front

panel. Then adjust  $L_1$  until 3.5 ma. is obtained on the test meter. Turn the transmitter off and replace the plate cap on the 2E26 tube. Insert a test meter of approximately 100 ma. in the plate current jack ( $J_2$ ) and adjust  $C_9$ ,  $C_{10}$ , and  $C_{11}$  for maximum capacity. Again turn the transmitter on and allow it to warm up. Then adjust  $C_9$  (plate tuning) for minimum plate current (lowest dip on meter reading) and then decrease the capacity of  $C_{10}$  (output tank loading) approximately  $\frac{1}{10}$  turn. Re-adjust  $C_9$  for the plate current dip and continue to decrease the capacity of  $C_{10}$  and re-adjust  $C_9$  until the plate current is 50 ma. at the lowest point of the plate current dip reading. The adjusting of  $C_9$  for a dip should always be the final adjustment in the tuning up procedure. The final setting of  $C_9$  will normally be found to be about  $\frac{1}{3}$  to  $\frac{1}{2}$  meshed.  $C_{10}$  will be between  $\frac{1}{3}$  to  $\frac{2}{3}$  meshed and  $C_{11}$  will be fully meshed.

Excessive loading or antenna coupling is indicated by plate current in excess of 50 ma. If plate current at the dip is less than this, it indicates insufficient coupling or loading. To increase the loading, adjust the output tank coupling  $C_{10}$  by decreasing the capacity slightly. As a rule of thumb, it may be remembered that increasing the capacity of  $C_{10}$  (output tank coupling), decreases the loading. Conversely, decreasing the value of  $C_{10}$  increases the loading which, of course, always results in increased plate current. Any adjustment of  $C_{10}$  (output tank coupling) always requires a re-

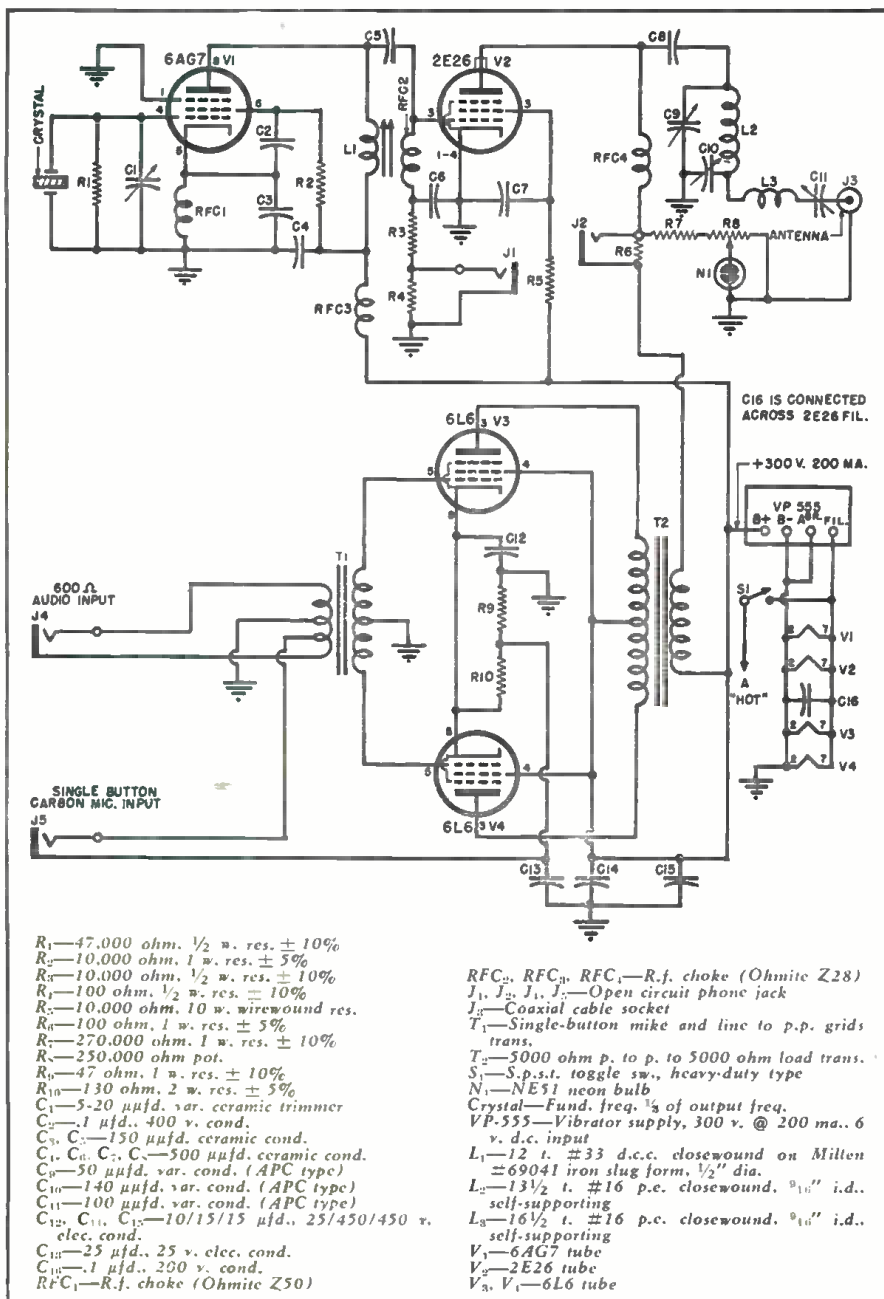

- R<sub>1</sub>—47,000 ohm, 1/2 w. res. ± 10%
- R<sub>2</sub>—10,000 ohm, 1 w. res. ± 5%
- R<sub>3</sub>—10,000 ohm, 1/2 w. res. ± 10%
- R<sub>4</sub>—100 ohm, 1/2 w. res. ± 10%
- R<sub>5</sub>—10,000 ohm, 10 w. wirewound res.
- R<sub>6</sub>—100 ohm, 1 w. res. ± 5%
- R<sub>7</sub>—270,000 ohm, 1 w. res. ± 10%
- R<sub>8</sub>—250,000 ohm pot.
- R<sub>9</sub>—47 ohm, 1 w. res. ± 10%
- R<sub>10</sub>—130 ohm, 2 w. res. ± 5%
- C<sub>1</sub>—5-20 μfd. var. ceramic trimmer
- C<sub>2</sub>—1 μfd., 400 v. cond.
- C<sub>3</sub>, C<sub>4</sub>—150 μfd. ceramic cond.
- C<sub>5</sub>, C<sub>6</sub>, C<sub>7</sub>, C<sub>8</sub>—500 μfd. ceramic cond.
- C<sub>9</sub>—50 μfd. var. cond. (APC type)
- C<sub>10</sub>—140 μfd. var. cond. (APC type)
- C<sub>11</sub>—100 μfd. var. cond. (APC type)
- C<sub>12</sub>, C<sub>13</sub>, C<sub>14</sub>—10/15/15 μfd., 25/450/450 v. elec. cond.
- C<sub>15</sub>—25 μfd., 25 v. elec. cond.
- C<sub>16</sub>—1 μfd., 200 v. cond.
- RFC<sub>1</sub>—R.f. choke (Ohmic Z50)

- RFC<sub>2</sub>, RFC<sub>3</sub>, RFC<sub>4</sub>—R.f. choke (Ohmic Z28)
- J<sub>1</sub>, J<sub>2</sub>, J<sub>3</sub>, J<sub>4</sub>—Open circuit phonic jack
- J<sub>5</sub>—Coaxial cable socket
- T<sub>1</sub>—Single-button mike and line to p.p. grids trans.
- T<sub>2</sub>—5000 ohm p. to p. to 5000 ohm load trans.
- S<sub>1</sub>—S.p.s.t. toggle sw., heavy-duty type
- N<sub>1</sub>—NE51 neon bulb
- Crystal—Fund. freq. 1/3 of output freq.
- VP-555—Vibrator supply, 300 v. @ 200 ma., 6 v. d.c. input
- L<sub>1</sub>—12 t. #33 d.c.c. closewound on Millen #69041 iron slug form, 1/2" dia.
- L<sub>2</sub>—13 1/2 t. #16 p.c. closewound, 9/16" i.d., self-supporting
- L<sub>3</sub>—16 1/2 t. #16 p.c. closewound, 9/16" i.d., self-supporting
- V<sub>1</sub>—6AG7 tube
- V<sub>2</sub>—2E26 tube
- V<sub>3</sub>, V<sub>4</sub>—6L6 tube

Diagram of mobile 10 meter transmitter. Any power supply delivering 300 volts at 200 milliamperes can be used. Transmitter delivers 10 watts amplitude modulated.

adjustment of C<sub>9</sub> (plate tuning) to bring the circuit back to resonance. Resonance is indicated by the plate current dip.

Touching a quarter-watt neon bulb to the top end of the whip antenna should produce a red glow in the bulb which indicates there is reasonable transfer of energy to the radiating system. But a neon bulb should never be relied upon as a tune-up indicator as this will result in excessive plate dissipation in the 2E26 tube, damaging it or greatly reducing its useful life. Excessive distortion may also result. A test meter should always be used to measure the plate current of the 2E26 tube when tuning the power amplifier circuit.

After the adjustment of antenna loading and plate tuning has been completed, it is advisable to recheck

the grid current of the 2E26 tube. This may be accomplished by means of the test meter and the grid current jack provided on the front panel. Grid current should not exceed 4 ma. for maximum life of the tube but satisfactory operation will result for any value of grid current between 2.5 and 4 ma. L<sub>1</sub> may be adjusted for the correct current. A value of 3.5 ma. is to be preferred.

The variable condenser (C<sub>1</sub>) connected across the crystal requires just an initial adjustment in conjunction with a reliable frequency standard as it is a vernier control upon the frequency and once set should not require further adjustment due to normal vibration or other effects. Once set, the oscillator plate tank circuit should require no additional tuning for any particular frequency and, in the power

amplifier circuit, only the plate and antenna loading adjustments require an occasional retuning. R<sub>8</sub> is a variable control which determines at what percentage of modulation the neon bulb will flash. This control should be adjusted so that the neon bulb flashes when modulation peaks of 100% are exceeded. An oscilloscope and a sine wave audio generator are required for this operation.

### Dummy Antenna

As is the case with most transmitters, attempting to tune or operate the transmitter in an unloaded condition will result in damage to the components of the output network. To eliminate the necessity of tuning the transmitter with the antenna connected, an effective dummy antenna at this frequency can be easily constructed from a 25 watt, 32 volt light bulb. To do so, remove the base from the light bulb, being careful to preserve the leads. Then insert one of the protruding leads into the output receptacle (J<sub>3</sub>) of the transmitter and secure the other lead to the chassis near the receptacle and proceed with the tune-up.

### Modulation

Modulation of the transmitter is accomplished by means of jacks provided on the front panel. 100% modulation can be obtained by applying a level of approximately 0 db. through J<sub>1</sub>, by the use of an audio signal generator or a remote amplifier. By using a single button carbon microphone plugged into J<sub>5</sub>, 100% modulation can also be obtained without the use of any other amplifier. Excitation voltage of approximately 5.5 volts for the microphone is obtained from a tap on the cathode bias resistor of the 6L6 modulator tubes.

### Reception

The power output of the transmitter is 10 watts amplitude modulated and it can be received over a distance of from five to ten miles with an ordinary communications receiver, depending on the intervening terrain and the car's position with respect to the receiving antenna. When the transmitting whip antenna is mounted on the rear bumper, field experience has shown that often a 2 to 6 db. signal strength gain may result when the front of the automobile is pointed towards the receiving antenna. Apparently the body tends to act as some sort of directive factor, increasing the frontal radiation somewhat. For best results, the receiving antenna should be as high as possible and cut to resonance at the operating frequency. Where feasible, a vertically polarized beam antenna at the receiving end will further extend the maximum usable range. Line of sight between the receiving and transmitting antenna is highly advantageous. Hills between the two antennas should be avoided if possible. Buildings and trees are highly absorptive at these frequencies and will cause some loss of

signal strength if they come between the receiving and transmitting antennas. Receiving locations having low electrical noise levels and freedom from automobile ignition interference will extend the usable coverage distance considerably.

#### Installation and Operation

The complete transmitter, consisting of two basic units—the transmitter proper and a standard vibrator type power supply, is only 18 $\frac{1}{2}$ " long, 8" wide, and 11" tall including shock mounts. Thus it lends itself especially well to mounting in the trunk of an automobile and the 6 volt battery is reasonably accessible merely by running two leads from the transmitter to the battery. If the antenna is mounted on the rear bumper, only a short length of coaxial cable is required to connect the antenna to the transmitter. The power supply will not be discussed here as any power supply that provides 6.3 volts for the filament and 300 volts d.c. at 200 ma. for the rest of the transmitter will suffice. Information on building such a supply can be obtained elsewhere. Incidentally, the transmitter should not be operated on a battery where the voltage measured at the transmitter input terminals is less than 5.8 volts as power output decreases rapidly and distortion increases excessively. Where the battery is known to be fully charged and low voltage is experienced at the transmitter input terminals, a voltage drop across the resistance of the connecting leads should be suspected or the possibly corroded connection investigated. This voltage drop can be eliminated by using two #8 wires (or larger) rather than depending on the car body to form one of the connecting leads. When corrosion of the body takes place an appreciable voltage drop may be experienced.

A length of RG-8U coaxial cable should be used to connect the transmitter output to the base of the 8 foot whip antenna. The impedance of this

coaxial cable is 52 ohms which comes fairly close to matching the impedance of the antenna.

A rig of this type makes an ideal portable or emergency standby. A power supply to operate off a.c. lines may be readily built of ordinary receiver replacement parts. Stock replacement transformers in this rating are generally available.

As the microphone current is supplied from the drop across the cathode resistor in the modulator tubes, no provision need be made for a separate source of d.c. for this purpose. Thus one of the design headaches of a dual purpose transmitter is eliminated.

Designed for those who must confine the bulk of their operating to mobile, this rig is also suitable for home operation since its low power should cause little TVI.

A multi-element beam antenna could be erected at the home station, giving the effect of considerably higher power.

A dynamotor or vibrator supply can be mounted in the car along with the whip antenna. Plug-in power cables will make the job of changeover a mat-

ter of a few minutes, and save the cost of an additional rig.

#### Parts Replacement

About the only parts that will need replacing will be the tubes. Weak 6L6 tubes will be evidenced by excessive distortion. A weak 6AG7 tube will probably refuse to oscillate or will not provide enough drive for the power amplifier stage. A weak 2E26 tube will cause reduced output and exhibit an inability to load up to 50 ma. plate current.

The noise, distortion, and frequency response of the transmitter exceeds class A network program lines and meets all requirements of the FCC pertaining to AM broadcasting stations. The frequency stability is plus or minus .005% and incidental frequency modulation is less than 100 cycles. Frequency response from 100 to 10,000 cycles is within 2 db. of being completely flat and the maximum distortion is 3 $\frac{1}{2}$ % between 100 to 7500 cycles at 85% modulation. Noise is better than 50 db. below 100% modulation.

-30-

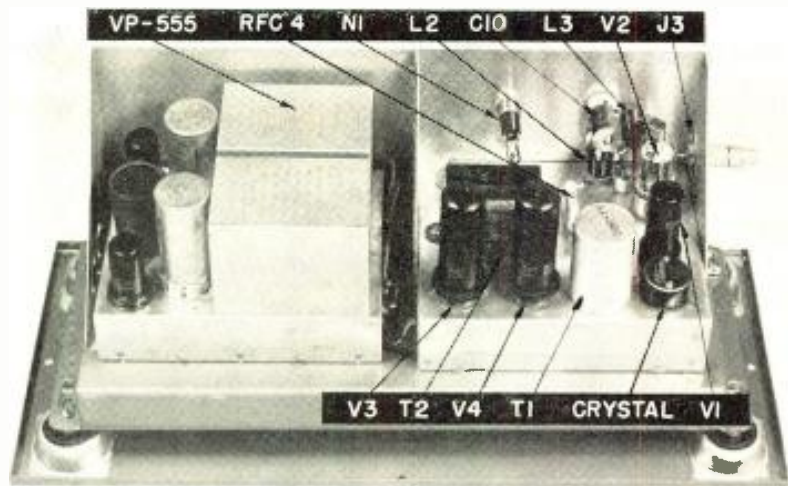

Rear view of completed unit showing location of various components. Refer to schematic diagram for parts identification. A vibrator-type power supply was used to furnish "B" voltage while the filament voltage was obtained from car battery.

(Left) Bottom view of transmitter. (Right) Rear view of transmitter portion with tubes removed. Either APC type trimmer condensers can be used for C<sub>10</sub> or C<sub>11</sub>, as indicated in the parts list, or ceramic type condensers, shown in the author's rig, can be used.

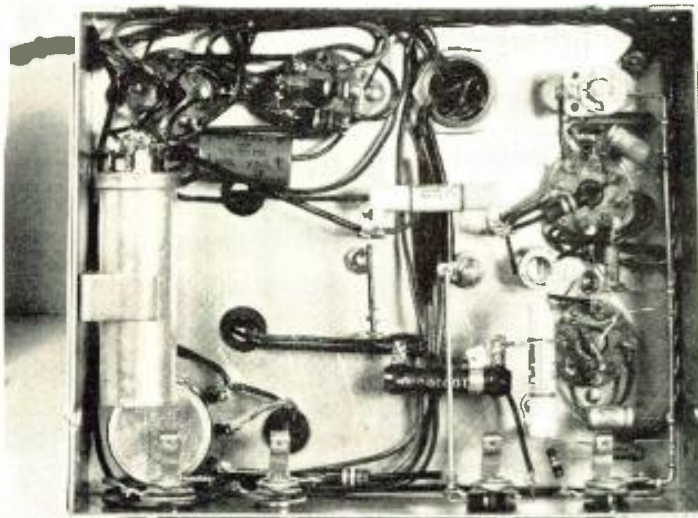

# RESISTANCE WELDING

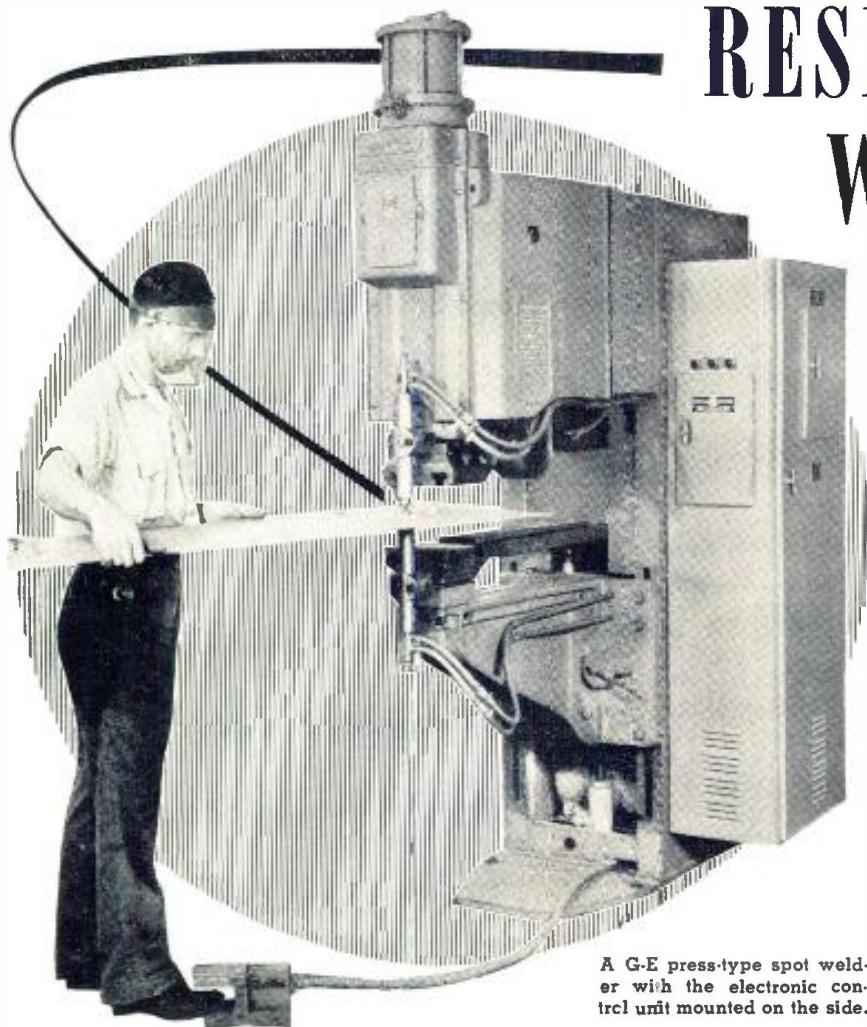

A G-E press-type spot welder with the electronic control unit mounted on the side.

**Resistance welding techniques provide a new tool for joining metals swiftly without using solders.**

By  
**ED BUKSTEIN**

**N**URTURED in the favorable climate of electronic control, resistance welding has become a rapid and efficient operation. As a result, production schedules and costs have been reduced, and welded assemblies are of uniformly high quality.

Resistance welding is a method of joining two or more pieces of metal by passing a high current through them. The heat developed as a consequence of this current melts the metals together, producing a strong joint. Unlike brazing and other methods, resistance welding adds no additional material to the work, and "lumpy" joints are avoided.

The welding current must be accurately controlled both in intensity and duration. Insufficient current or current for an insufficient length of time will result in poor fusion and a weak joint. At the other extreme, excessive current will burn holes in the metal. The answer to these exacting demands lies in the electronic circuits which accurately control both

the duration and magnitude of the current.

The principle of resistance welding is illustrated in Fig. 1. The metal plates to be welded are held between two copper-alloy electrodes. Secondary current of the transformer, passing through the metal plates, produces the heat and the resulting weld. The welding transformer has a step-down ratio. Secondary voltage in the five to fifteen volt range is common in this application. This step-down of voltage is, of course, accompanied by a step-up of current.

Since rod-shaped electrodes are used, the weld is small and circular, corre-

Fig. 1. The principle of resistance welding. When the switch is closed, the transformer secondary passes a high current through metal plates. Heat developed as a result of current welds metals together.

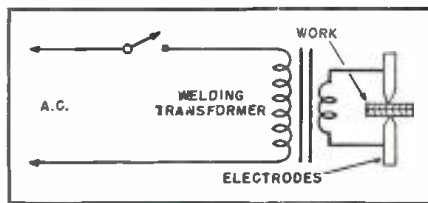

sponding to the end area of the electrodes. This is *spot welding*. The complete welding operation can be divided into three intervals of time. First, the metals must be brought into position and pressure applied to the electrodes. This interval is called the *squeeze time*. Secondly, power is applied and current passes through the metals. This is the *heat time*. Thirdly, the current is stopped but the metals remain in position under pressure of the electrodes. This is called the *hold time* and permits the weld to "set."

Hollow electrodes are sometimes used and water circulated through them to prevent overheating of the copper. Another cooling expedient is a system known as *pulsation welding*. Here, the heat time is broken down into a number of smaller intervals during which power is alternately applied and removed. The welding cycle under this arrangement would be as follows; squeeze time, heat time, cool time, heat time, cool time, heat time, hold time. During the cool time intervals, the heat is removed from the copper electrodes by the circulating water. The work, however, retains most of its heat during this period.

If the rod-shaped electrodes are replaced by a pair of rollers, and the work is passed between these rollers, a continuous *seam weld* will be produced. If pulsation welding is used in conjunction with these rollers, a series of uniformly spaced welds will be produced.

## Use of the Ignitron

In the circuit of Fig. 1, the weld is produced by bringing the work into position and closing the switch for the required length of time. This arrangement is not satisfactory, however. In the first place, it is not possible to manually operate the switch at the high rate demanded by mass production techniques. Secondly, the duration and consequently the quality of each weld would be subject to errors of human judgment on the part of the operator. The duration of the weld is often only a few cycles of the line current, a requirement beyond the possibilities of both switch and operator.

The shortcomings outlined above can be resolved by replacing the switch with a tube. By the application of proper control voltage to its grid, the tube can be made conductive and non-conductive at the desired switching rate and for the optimum duration. The choice of tube for this application becomes mainly a question of current

(Continued on page 136)

# Cabinets for High-Quality Direct Radiator Loudspeakers



Fig. 1. Microphone and loudspeaker under test in a free field room.

By  
**HARRY F. OLSON**

RCA Laboratories  
Princeton, New Jersey

## *An analysis of the various factors involved in the design and construction of good speaker enclosures.*

**D**IRECT radiator loudspeaker mechanisms for wide range sound reproduction are usually mounted in cabinets. In this system, there are four general parameters that influence the performance of the loudspeaker mechanism, namely, the internal acoustical impedance of the cabinet, the damping of the interior of the cabinet, the mounting of the loudspeaker mechanism, and the shape or the configuration of the outside of the cabinet. Since the effects of these parameters are independent of one another and occur in different portions of the frequency range, it is possible to analyze, measure, and segregate the different phenomena. For example, the size of the cabinet together with the loudspeaker mechanism characteristic determines the response in the low frequency range. The damping of the inside of the cabinet affects the response in the low and mid-frequency ranges. The mounting arrangement of the loudspeaker mechanism in the cabinet influences the response due to cavity resonance and diffraction in the high and mid-frequency ranges. The shape of the outside of the cabinet affects the response in the high and mid-frequency ranges due to diffraction. It is the purpose of this article to consider the above mentioned four different parameters that influence the performance of a direct radiator loudspeaker mechanism mounted in a completely enclosed cabinet.

### Measurement Apparatus

The loudspeaker response frequency characteristics depicted in this article were all taken in the free field sound room at the *RCA Laboratories* in

Princeton, N. J. The response frequency characteristics were obtained by means of the automatic recording system shown schematically in Fig. 2. The output of an *RCA* Type 68B beat frequency oscillator is fed to an *RCA* Type BA-14A monitoring amplifier. The output of the monitoring amplifier is fed to the loudspeaker under test. The loudspeaker and microphone under test are located in the free field room<sup>1,2</sup> as shown in the photograph of Fig. 1. The sound output of the loudspeaker is picked up by means of an *RCA* Type 44BX velocity microphone. The microphone was calibrated by the reciprocity<sup>3,4</sup> method. The output of the microphone is fed to an *RCA* BA-11A preamplifier. This ampli-

fier is compensated so that for constant sound pressure in free space the recorded output of the *Leeds and Northrup* "Speedomax" level recorder will be independent of the frequency.

### Cabinet Volume

The considerations in this article will be confined to completely enclosed cabinets for the following reasons: Open back cabinets exhibit accentuated response in the region of cabinet resonance. It appears that it is difficult to control and subdue this resonance and thereby obtain a smooth response frequency characteristic. Therefore, open back cabinets have not been considered to be suitable for high quality wide range sound reproduction. The design of phase inverter or ported cabinets involves special tests and development work to obtain the optimum results. Unless this work is carried out with adequate test facilities, the performance will not be satisfactory. For example, equipment for

<sup>1</sup>Olson, H. F.; *Journal Acoustic Society of America*, Vol. 15, No. 2, 1943, page 96.  
<sup>2</sup>Olson, H. F.; "Elements of Acoustical Engineering," D. Van Nostrand Co., New York, Second Edition, 1947, page 359.  
<sup>3</sup>Olson, H. F.; *RCA Review*, Vol. 6, No. 1, 1941, page 36.  
<sup>4</sup>Olson, H. F.; "Elements of Acoustical Engineering," D. Van Nostrand Co., New York, Second Edition, 1947, page 345.

Fig. 2. Apparatus used to obtain response frequency characteristic of loudspeakers.

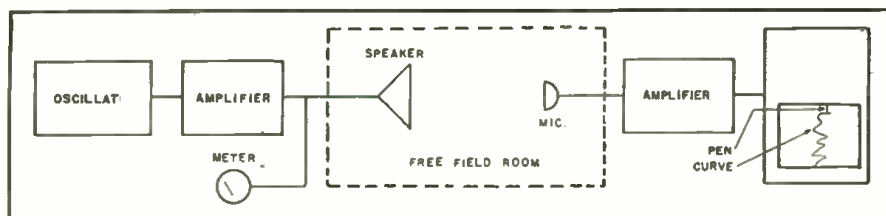

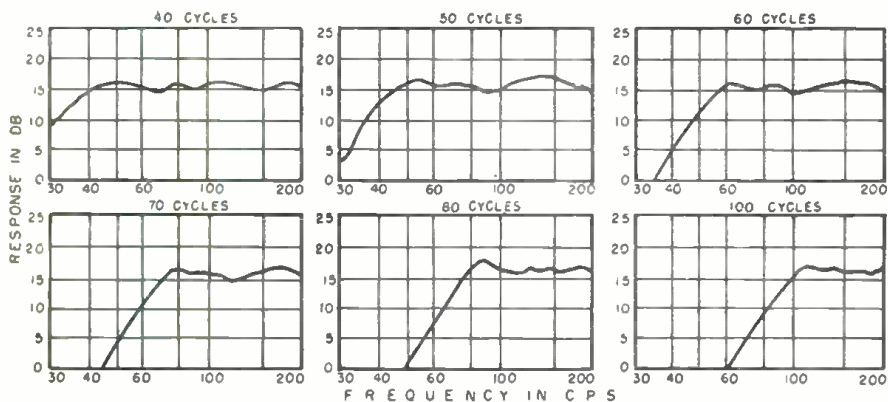

Fig. 3. Typical response frequency characteristics of 15" direct radiator loudspeaker mechanisms mounted in completely enclosed cabinets. The resonant frequency of the combination of the speaker mechanism and the cabinet is given above each of the graphs.

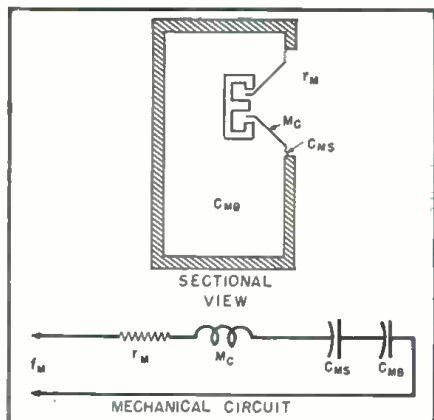

Fig. 4. Sectional view and mechanical circuit of a direct radiator loudspeaker mechanism mounted in a completely enclosed cabinet. In the mechanical circuit  $f_M$  = driving force,  $r_M$  = mechanical resistance of air load and suspension system,  $m_C$  = mass of the cone, voice coil, and air load,  $C_{MS}$  = compliance of the suspension system, and  $C_{MB}$  = compliance due to the cabinet volume.

obtaining the response frequency characteristics is almost mandatory. The only advantage of a phase inverter system is accentuated response in the low frequency region. This increased response is obtained at the expense of low frequency range. That is, the low frequency cut-off is lower in the com-

pletely enclosed cabinet than in the phase inverter or ported cabinet.

Since 15" loudspeaker mechanisms are almost universally used for wide range sound reproduction, the considerations in this article will be confined to this size mechanism. Typical response frequency characteristics for 15" loudspeakers for six different resonant frequencies are shown in Fig. 3. From these curves the builder can determine the characteristic he desires. As will be developed later the particular low frequency response may be tempered by the maximum volume of the cabinet which he is able to use. Since the characteristics of Fig. 3 are in terms of the resonant frequency of the loudspeaker mechanism and the cabinet volume, the next logical consideration is the determination of the resonant frequency of this combination.

The resonant frequency of a direct radiator loudspeaker mechanism located in a completely enclosed cabinet as shown in Fig. 4 is given by:

$$f_R = \frac{1}{2\pi} \sqrt{\frac{C_{MB} + C_{MS}}{m_C (C_{MB} C_{MS})}} \quad (1)$$

where:

- $m_C$  = mass of the cone, coil, and air, in grams
- $C_{MS}$  = compliance of the suspension

Fig. 5. The fundamental resonant frequency of the combination of a direct radiator loudspeaker mechanism mounted in a cabinet as a function of the cabinet volume. Numbers above graphs refer to resonant frequency of mechanism. The numbers on the curves give the mass of the cone, voice coil, and the air load.

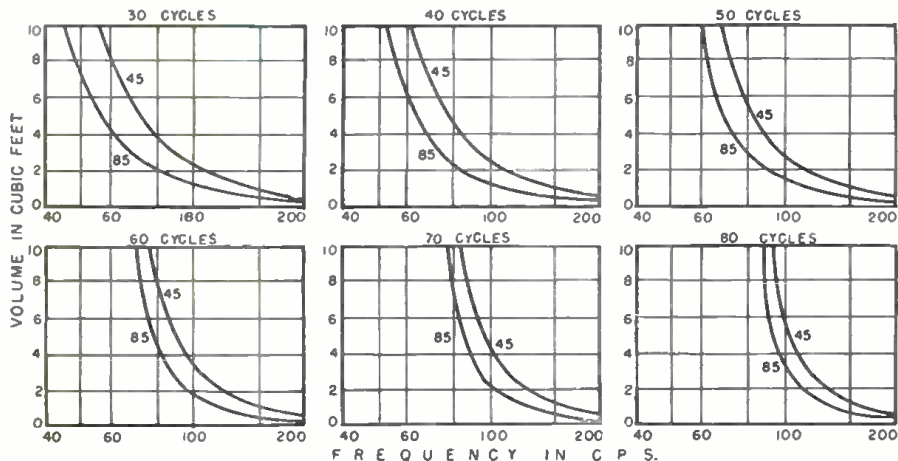

system, in centimeters per dyne

$C_{MB}$  = compliance of the cabinet, in centimeters per dyne.

The compliance<sup>5</sup> of the cabinet,  $C_{MB}$ , in centimeters per dyne, is given by:

$$C_{MB} = \frac{V}{\rho c^2 S_r^2} \dots \dots (2)$$

where:

$V$  = volume of the cabinet, in cubic centimeters

$\rho$  = density of air, in grams per cubic centimeter

$c$  = velocity of sound, in centimeters per second

$S_r$  = effective area of the cone, in square centimeters.

The effective diameter of the cone of a "15 inch" loudspeaker mechanism is about 13 inches.

It should be mentioned in passing that Equation (2) assumes that the phase is the same for all elements of volume within the cabinet. If there is phase shift within the cabinet, there will be some deviation from the mechanical impedance obtained from distributed constant theory<sup>6</sup>. Actually, there is a phase shift within the cabinet for all frequencies. However, the phase shift decreases as the frequency decreases. Therefore, the discrepancy between the lumped and distributed constant theories will decrease as the frequency decreases. Equation (2) is used in this article to determine the resonant frequency of the combination of the loudspeaker mechanism and cabinet volume. At this frequency, the dimensions of any practical cabinet will be a small fraction of the wavelength. Under these conditions, the phase difference between the elements of volume within the cabinet will be small. Therefore, the discrepancy between the lumped constant value of Equation (2) and the distributed constant value is negligible.

The effective mass of the combination of the cone, voice coil, and the air load of the loudspeaker can be determined as follows: The loudspeaker should be placed in a flat baffle having dimensions of at least three feet by three feet. The resonant frequency,  $f_R$ , of the loudspeaker is determined by driving it from an oscillator and noting the frequency at which the maximum amplitude is obtained. Now a known mass,  $m_c$ , is glued to the cone of approximately the same mass as the cone. The resonant frequency,  $f_{RW}$ , of this combination is determined by noting the frequency of maximum amplitude. From these constants the effective mass,  $m_e$ , in grams, of the cone, voice coil, and air load can be obtained from the expression:

$$m_e = \frac{f_{RW}^2}{f_R^2 - f_{RW}^2} m_c \dots \dots (3)$$

where:

<sup>5</sup> Olson, H. F.; "Elements of Acoustical Engineering," D. Van Nostrand Co., New York, Second Edition, 1947, page 152.

<sup>6</sup> Meeker, Slaymaker & Merrill; Journal Acoustical Society of America, Vol. 22, 1950, page 200.

$m_c$  = effective mass of the cone, in grams  
 $m_w$  = mass of the added weight, in grams  
 $f_r$  = resonant frequency of the loudspeaker, in cycles per second  
 $f_{rw}$  = the resonant frequency of the loudspeaker with the mass  $m_w$  added, in cycles per second.

The compliance of the suspension system,  $C_{us}$ , in centimeters per dyne is given by:

$$C_{us} = \frac{1}{(2\pi f_r)^2 m_c} \dots (4)$$

where:

$C_{us}$  = compliance of the suspension system, in centimeters per dyne  
 $f_r$  = resonant frequency of the loudspeaker in cycles per second  
 $m_c$  = mass of the cone, voice coil and air load, in grams, and as determined from Equation (3).

Now all the constants of the system are known. The cabinet volume required to obtain a particular resonant frequency of the combination of the loudspeaker mechanism and cabinet can be determined from Equations (1), (2), (3) and (4). If the builder does not want to carry out the computations, he can obtain a reasonably accurate value of this resonant frequency from the procedure which will be explained in the next paragraph.

The resonant frequencies of the combination of 15 inch direct radiator loudspeaker mechanisms and completely closed cabinets, as a function of the cabinet volume, are shown in Fig. 5. Graphs are given for six resonant frequencies,  $f_r$ , of the loudspeaker mechanism mounted in a large flat baffle. The resonant frequencies are 30, 40, 50, 60, 70, and 80 cycles. Graphs for heavy and light cones are given for each resonant frequency. These two weights represent the two extremes of combined cone, coil, and air load mass. It is possible to estimate whether the cone is heavy, light, or medium by inspection of different loudspeakers. The resonant frequency of the loudspeaker mechanism can be determined by the oscillator method as outlined before or from the manufacturer's data. From the graphs provided, it is possible to interpolate between cone weights and resonant frequency of the mechanism to obtain the required cabinet volume from the resonant frequency of the combination.

### Preferred Cabinet

The cabinet shown in Fig. 6 has been found to be particularly suitable for 15 inch wide range loudspeaker mechanisms as, for example, the RCA Types LC1A, 515S1, and 515S2. The internal volume of the cabinet shown in Fig. 6 is 8 cubic feet. The cabinet can be scaled up or down in volume by appropriate changes in the dimensions. It will be seen that the cabinet is made of relatively heavy wood with suitable bracing for reducing the vibration of the large flat surfaces. It will be shown in a later section that

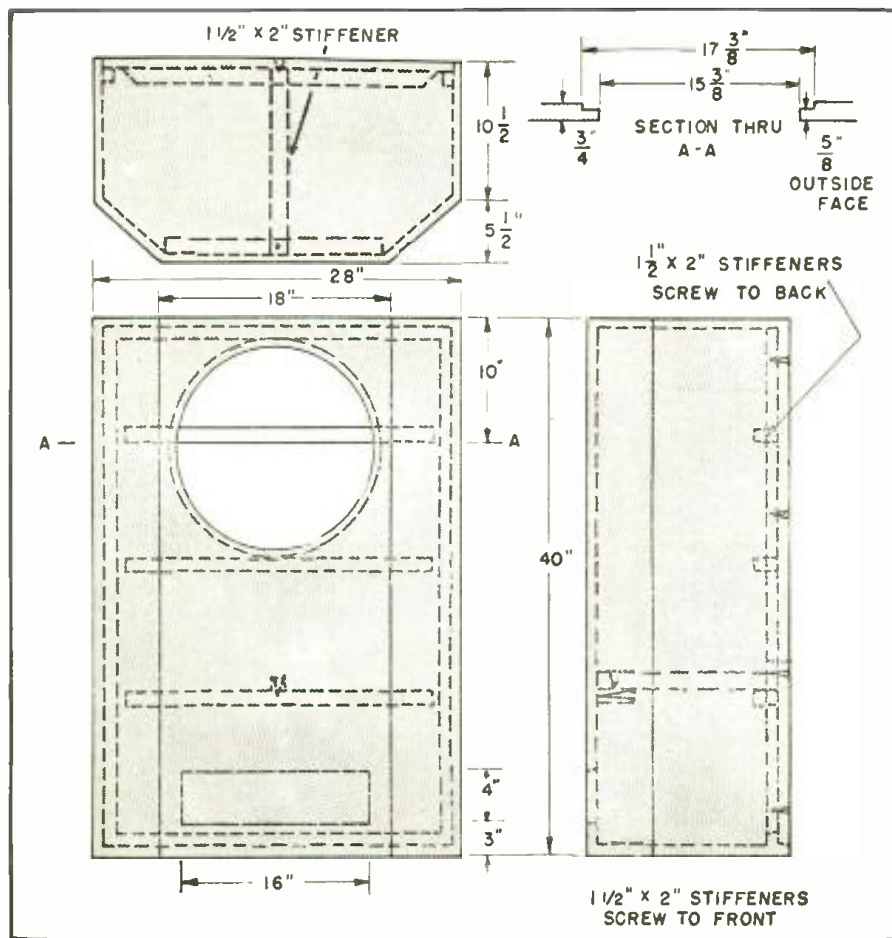

Fig. 6. Front, plan, and side views of a properly engineered loudspeaker housing.

the vibration of the walls of a cabinet introduces large variations in the response frequency characteristic. The inside surfaces of the cabinet are treated with absorbing material to reduce the standing sound wave system inside the cabinet. It will be shown in a later section that the standing sound waves in an undamped cabinet produce wide variations in the response frequency characteristic. The loudspeaker mechanism is mounted flush with the front surface of the cabinet. It will be shown in a later section that the resonance and diffraction

effects produced by a cavity in front of the cone will introduce variations in the response frequency characteristic. The outside configuration of the cabinet introduces variations in the response frequency characteristic due to diffraction. It will be shown in a later section that the outside configuration of this cabinet reduces the deleterious effects of diffraction upon the response frequency characteristic.

A cabinet of the type shown in Fig. 6 will be used in the sections which follow to illustrate the effects of cabinet wall vibration, standing sound waves

Fig. 7. Response frequency characteristic of a 15" loudspeaker mechanism mounted in a cabinet of the type shown in Fig. 6. (A) Showing the elimination of deleterious effects due to the vibration of the cabinet by the use of heavy and well braced walls. (B) Response when deviations, i.e., walls made of thinner wood and the elimination of stiffeners, in the design of Fig. 6 were permitted.

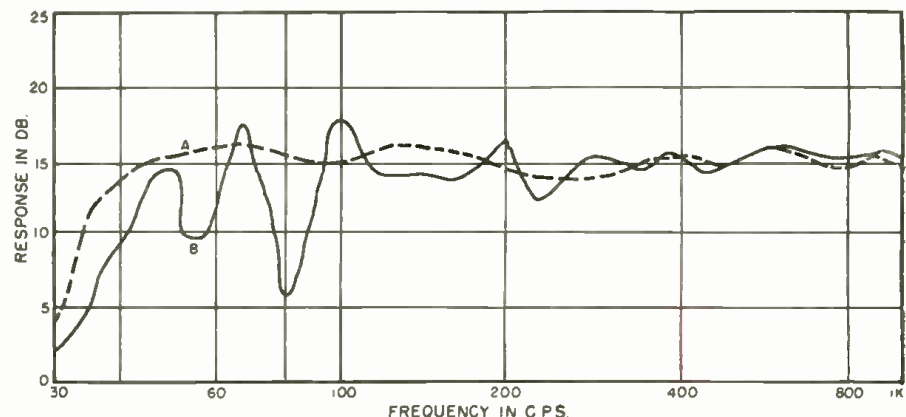

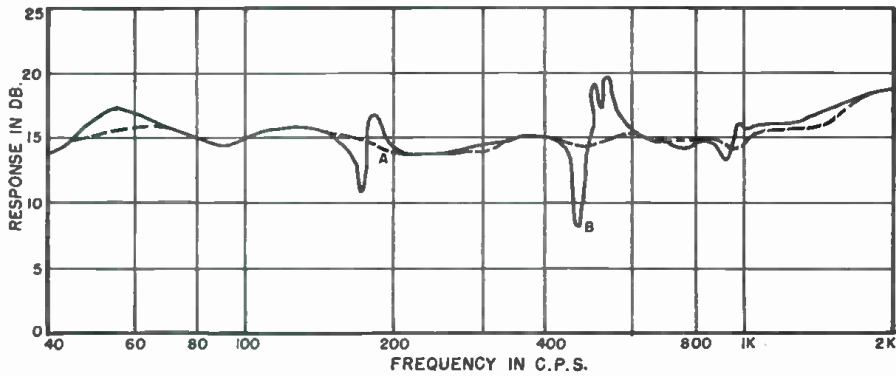

Fig. 8. Response frequency characteristic of a 15" loudspeaker mechanism mounted in the cabinet shown in Fig. 6. (A) Good response obtained by treating inside of cabinet with damping material. (B) Poor response when damping material was omitted.

within the cabinet, loudspeaker mechanism mounting in the wall of the cabinet, and the exterior configuration of the cabinet upon the response frequency characteristic. The experiments to illustrate these effects were carried out so that the result and response frequency characteristic would depict the effect of one phenomenon at a time. This procedure will be evident in the text describing the tests and the results obtained.

The RCA Type LC1A loudspeaker mechanism was used in the tests which will be described in the sections which follow. The mass of the cone, voice coil, and air load of this loudspeaker mechanism is 85 grams. The measured resonant frequency of the mechanism used in these tests was 35 cycles. The resonant frequency of the combination of the loudspeaker mechanism and the preferred cabinet shown in Fig. 6 was 52 cycles.

#### Cabinet Wall Construction

In order to obtain smooth response in the low frequency region, it is necessary to use a well braced cabinet. If the walls of the cabinet are allowed to vibrate, peaks and dips will be introduced in the response, because the vibration of the different panels of the cabinet causes the radiation of sound from these panels which may be in-

out-of-phase with the sound radiated by the cone. Furthermore, the vibration of the heavy, high "Q" panels of the cabinet introduces poor transient response, because the build-up and decay periods of the excited panels are very long.

In order to confine the effects of the vibration of the walls of the cabinet without any other effects which mar the response, a cabinet of the configuration and dimensions shown in Fig. 6 was used with the inside of the cabinet damped and the loudspeaker mounted flush with the front of the cabinet. The walls were made of thinner wood than that shown in Fig. 6. In addition, all bracing strips were eliminated. A typical response frequency characteristic of a loudspeaker mechanism mounted in a cabinet with vibrating walls is shown in Fig. 7B. It will be seen that the vibrating panels introduce wide variations in the response frequency characteristic. In this experiment, it is difficult to isolate the effect of the vibrating panels completely because the damping material mitigates the vibrations of the panels to some extent. The response frequency characteristic of a loudspeaker mechanism in a cabinet of the same dimensions as Fig. 6, but with rigid and well braced walls, is shown in Fig. 7A. The characteristics of Figs. 7A and 7B show that it is very important that a solid, well braced cabinet be used to insure a smooth response frequency characteristic. The walls of the cabinet should be made of wood  $\frac{3}{4}$  inch thick. Additional strips of  $1\frac{1}{2}$  inch by 2 inch hardwood should be glued or screwed to the inside of the panels having large flat areas as, for example, the back and the front of the cabinet. Additional bracing can be obtained by running a  $1\frac{1}{2}$  inch by 2 inch tie strip from the front to the back of the cabinet as shown in Fig. 6.

#### Cabinet Damping

Standing wave systems on the inside of the cabinet will interact with the loudspeaker cone to produce variations in the response frequency characteristic. This is due to the variation in acoustical impedance presented to the cone by the complex sound wave pattern in the cabinet. For example, if there is a pressure loop at the loud-

speaker cone, the acoustical impedance presented to the loudspeaker cone will be high and the motion of the cone will be retarded. If there is a particle velocity loop at the loudspeaker cone, the acoustical impedance presented to the cone will be small and the motion of the cone will be accentuated. The result will be corresponding dips and peaks in the response frequency characteristic. A typical response frequency characteristic of a loudspeaker mechanism mounted in the well braced cabinet of Fig. 6, but without damping material, is shown in Fig. 8B. In this case, the only deviation from the proposed cabinet of Fig. 6 is the absence of damping material. The ragged response in the region between 400 to 1000 cycles is due to standing waves within the cabinet. These standing wave patterns can be reduced, so that the effects upon the response frequency characteristic are negligible, by several different damping arrangements. One procedure is to line the front, back, and sides of the cabinet with 1 inch hair felt or the equivalent. The important thing is that the lining material should exhibit high absorption characteristics. Another procedure is to line the side walls and, in addition, hang a heavy blanket of hair felt across the full width of the cabinet half way between the front and the back. Still another method is to fill the entire volume with a fluffed out soft material such as kimpac. A typical response frequency characteristic, after the undamped cabinet has been treated with absorbing material, is shown in Fig. 8A. It will be seen that the variations in response exhibited by the undamped cabinet have been eliminated. Furthermore, the accentuated response at the resonant frequency has been reduced somewhat by the addition of the damping material.

#### Mounting Arrangement

The mounting arrangement of the loudspeaker mechanism in the front wall of the cabinet influences the response due to the resonances of the cavity in front of the mechanism. In addition, variations in the response are produced by reflection and diffraction from the circular boundary of this cavity. The standard mounting arrangement for loudspeaker mechanisms which has been used for years is shown in Fig. 9A. Referring to Fig. 9A, it will be seen that the cabinet wall forms a cavity in front of the loudspeaker. The resonances and anti-resonances of this cavity, as well as reflections and diffractions of this wall edge, introduce variations in the response frequency characteristic as shown in Fig. 10A(a). These variations in response can be reduced by the improved loudspeaker mechanism mounting arrangement as shown in Fig. 9B. It will be seen that the cavity in front of the loudspeaker mechanism has been materially reduced. The reflecting edge of the cutout in the cabinet

(Continued on page 84)

Fig. 9. Two different methods of mounting direct radiator loudspeaker mechanisms in wall of cabinet. (A) With mechanism mounted on back of cabinet wall. (B) Mechanism mounted flush with front surface of cabinet.

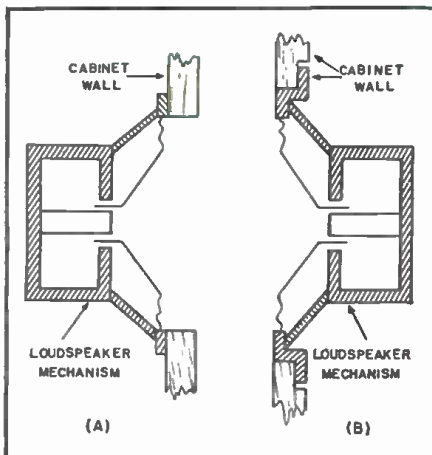



# A Novel Unit for Voice Controlled Operation



Over-all view of a voice control unit which can be added to any transmitter.

**An electronic robot—it will turn on your transmitter automatically at your command.**

By  
**E. A. ANDERSON.**  
**VE6OD**

**T**HE unit to be described was built for use at VE6OD and since it has worked out rather well the author thought other hams might be interested in the details. After looking over several circuits we decided to design something that would meet the need but be just a bit different. Since we did not want to make any changes in the transmitter itself, a different type of circuit had to be evolved. Also since we wanted the minimum of delay in putting the transmitter on the air when the mike was being used it was evident that something a little more elaborate than usual would be required.

From the circuit diagram it is easy to see that the first two tubes are used in an ordinary preamp layout. From there on the signal is passed through an ordinary 3:1 audio transformer and then rectified by the 6H6 tube. The potentiometer  $R_7$  and the condenser  $C_6$  make up the time delay determining circuit.  $C_6$  was made up of paralleled units in order to provide the odd value but a stock 4  $\mu$ fd. unit could be used if desired. The arm of the potentiometer is connected through limiting resistor  $R_8$  to the grid of the 2050 thyratron tube. This tube is designed to work from one side of the high voltage secondary of the power transformer and resistor  $R_{10}$  is a current limiting resistor. The value of  $R_{10}$  will depend on the transformer voltage.

$R_9$  is connected to ground and is designed to permit a small amount of a.c. to flow through the relay winding to prevent permanent magnetization of the core. The relay used is a tele-

phone type with normally-closed contacts and a coil resistance of 1000 ohms. Relays of greater sensitivity can be used if desired. Condenser  $C_7$  is connected across the relay coil and serves to filter out the pulsating d.c. from the plate of the 2050 thyratron and keeps the relay from chattering.

We found by experimentation that the best results with this unit were obtained when four tubes were used. One tube could have been eliminated but since the object was to get the transmitter on the air quickly and without losing too much of the first syllable, the fourth tube has paid off. The resultant circuit is almost equivalent to a regular speech amplifier which gives a good healthy sock quickly. Maximum delay appears to be 5

or 6 seconds. The timing usually used when on the fone net is 1 to 2 seconds which gives fairly snappy operation. No trouble was experienced with volume from the loudspeaker kicking the transmitter on except in cases of high frequency heterodyne. Of course, headphones can be used to make sure that such a thing will not happen and have been used by the author in cases of high QRM.

A number of relays are used in the transmitter to control operation as well as in the antenna circuit for switching and in the receiver for muting. A 24 volt supply is used to operate these relays and connections are made from the two binding posts on the unit to this circuit. In this way

(Continued on page 98)

Complete schematic diagram of the four-tube, voice controlled robot unit.

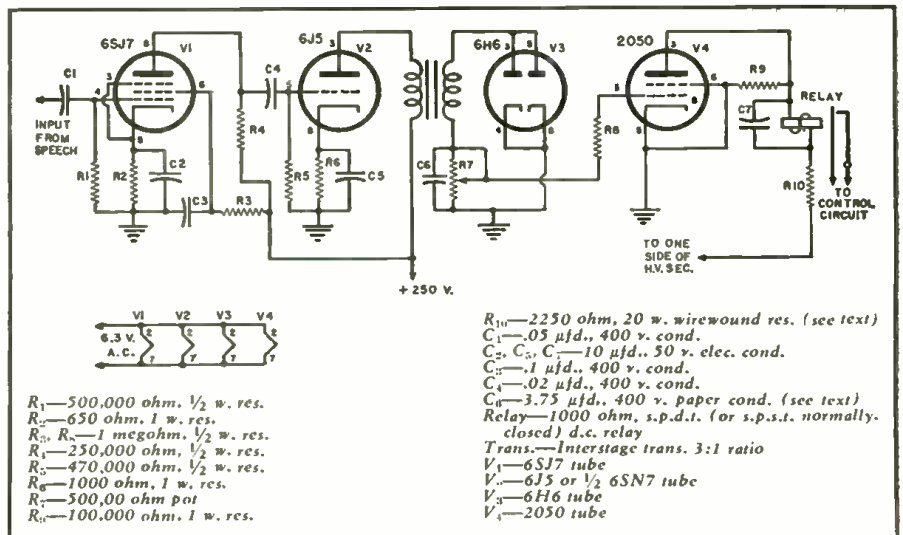

# A Small Rig With PLENTY OF POWER

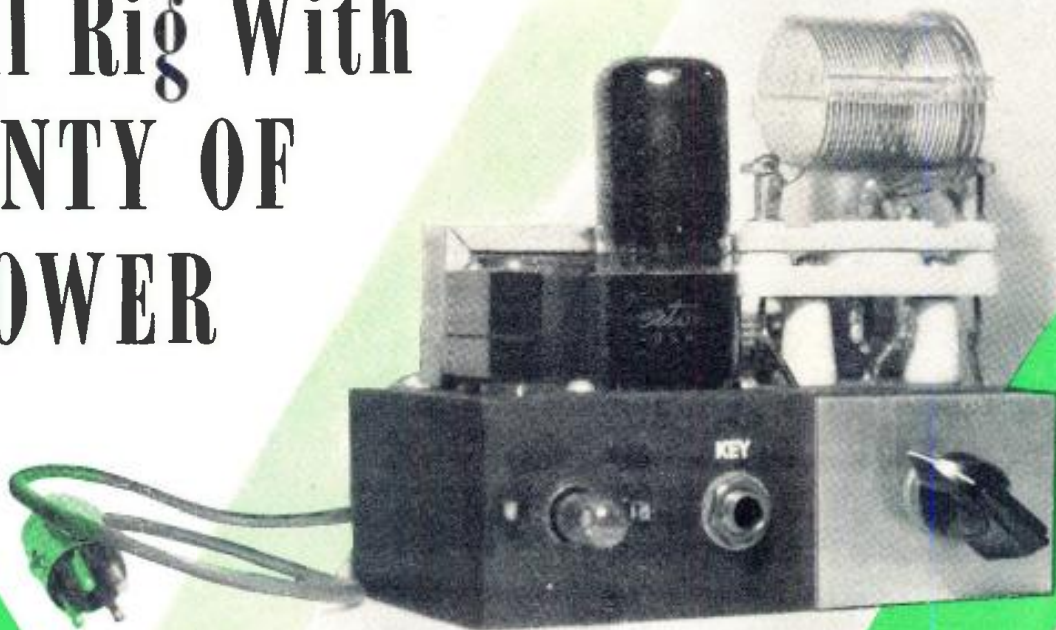

Over-all view of transmitter. Along the front of chassis can be seen tuning indicator lamp, key jack, and the plate tuning control.

By  
**LEON A. WORTMAN, W2LJU**

*Designed especially for the ham living in crowded quarters, this compact unit is rated at 12 watts.*

**A**T LEAST one ham I know has stayed off the air because of the apartment shortage. Whenever he expresses his frustrated desire to build a rig and pound brass, his wife draws herself up to her full 5 feet 2 inches and says, "What? In this two-by-four apartment you want to crowd the place with equipment when there isn't even enough room for me to hang my nylons!" That response has stopped the poor guy cold for the last three years. Each Saturday morning he can be seen with his nose pressed against the plate glass windows of the stores on radio row, a pathetic figure of a man. Out of sympathy for my friend and his fellow sufferers, I constructed a "small but powerful" rig, one that won't crowd the wife.

It's a 12-watt job, compact and efficient, easy to construct in an evening's time, ideal for the beginner, for the fellow who gets a kick out of compact equipment, and for the fellow who wants a standby installation. Any ham who has pounded brass will tell you that 12 watts of rig gets an operator plenty of DX and rag chews. The rig uses a 6V6GT tube as a crystal-controlled pentode oscillator and, except for the small power transformer, all components are mounted on a chassis that measures only 3"x5"x1 3/4". Contained on this chassis are the oscillator tube, crystal, tuning coil and con-

denser, the voltage doubler, and the power supply filter.

The only way to achieve this compact construction was to mount the power transformer as a separate unit. The elimination of rectifier tubes has been made possible by the availability of selenium rectifiers. These rectifiers are small, require no heater elements, are efficient and capable of withstanding high peak current surges without breakdown. The life expectancy of a selenium rectifier is quite long. They are available in a variety of ratings to meet all sorts of designs. For our purpose, the 75 milliamperere unit is excellent with its 900 milliamperere peak rating. Thus we have the power supply rectifiers. They can be installed without worrying about burnout. The power transformer is a *Merit #P-3045*,

which has a half-wave 117 volt, 50 milliamperere secondary, and a 6.3 volt, 1.5 ampere filament winding. The "high voltage" secondary is rated at a little under 6 watts but, because power is drawn intermittently (only when the key is down), it works quite nicely in this application without overheating. We obtain a voltage that is much higher than 117 from the secondary by using a voltage doubler circuit.

The voltage doubler is by no means a new or even recent invention. The idea has been used by many receiver manufacturers although I haven't seen many ham circuits making use of this technique. It's intriguing to think that one can take a voltage and, without the use of inductors or transformers, actually double it. And it really is quite simple. The basic circuit of a voltage doubler is shown in Fig. 1. The voltage doubler must operate from an alternating current power source. Because of the unidirectional characteristic of rectifiers, current flows through only one of the rectifiers for each half cycle of the line's alternating polarity. When the polarity at point A is positive with respect to point B, the current flow is as indicated by the solid arrow. This flow of current charges  $C_7$  and point  $a$  is positive with respect to point  $z$ . During the half cycle which makes point B positive with respect to point A, current flows only in the direction indicated by the broken arrow. This flow of current makes point  $z$  positive with respect to point  $b$ , charging  $C_{10}$ . This leads to the conclusion that, since  $C_7$  and  $C_{10}$  are in series from point  $a$  to point  $b$ , the voltage measured across  $a$  to  $b$  is the sum of the charges on the individual condensers. However, one condenser is discharging while the other is charging. The re-

Fig. 1. The basic voltage doubler circuit.

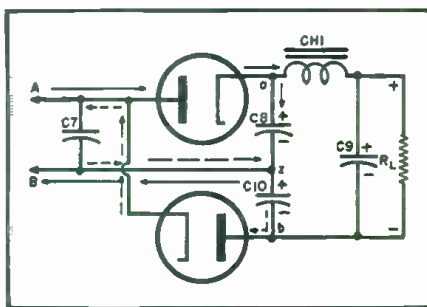

sulting output voltage is, therefore, not actually twice the voltage of the supply line. A more correct name than "voltage doubler" is voltage adder; the voltage across  $C_1$ , at any given instant, being added to the voltage across  $C_{in}$ . The ripple frequency of this circuit is twice the line frequency. In this regard, the "symmetrical voltage doubler" is similar to the full-wave rectifier. If condensers  $C_1$  and  $C_{in}$  are not approximately equal in value, the ripple voltage will contain a component of the line frequency. It is usually assumed that the two condensers of a voltage doubler circuit will be equal in value, and such is the case in the power supply of our little transmitter.

The capacitances of  $C_1$  and  $C_{in}$  very definitely affect the output voltage of the power supply. Fig. 2 shows the relationship between the capacitances, load current of the oscillator tube, and the output voltage. It is then obvious why 20  $\mu$ fd. has been selected as the value of both  $C_1$  and  $C_{in}$ . With the values given in the transmitter schematic wiring diagram of Fig. 3, the voltage output of the power supply is about 250.

The chassis layout can be seen in the photographs of the completed unit. The power supply components, except for the small power transformer, are mounted across the back edge of the chassis top. The radio frequency components occupy the remaining top space of the chassis. The power transformer is most conveniently mounted on a small block of wood approximately 3x4x $\frac{3}{4}$  inches.

If a larger chassis were to be used the transformer could be mounted with the balance of the transmitter.

The controls seen on the leading edge of the chassis are, from left to right, the tuning indicator light, the meter-key jack, and the plate tuning condenser. The antenna terminals are two Eby binding posts with insulated bases and shoulder washers to prevent short circuiting to the metal chassis. The tuning coils are National plug-in units, type AR-16. A National XB-16 socket mounts on the chassis top on stand-off insulators. By changing crystals and the plug-in coils, bands are selected. No "transmit-standby" switch is necessary for this rig since the 6V6GT oscillator tube draws current and goes into oscillation only when a meter or key is plugged into the jack. After the wiring has been completed and checked, the rig is ready to be tuned and put on the air.

The major reason for tuning up a transmitter is the same as when you connect the voice coil of a loudspeaker to the 8 ohm winding of an amplifier output transformer—to match impedances and gain a maximum transfer of power from one unit to the other. In the case of tuning up this little rig, you want to get a maximum of the power generated by the oscillator into the antenna. Your choice of the type of antenna depends entirely on your location, apartment, home, surround-

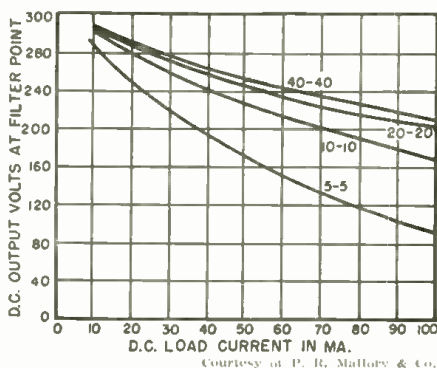

Fig. 2. Relationship between the capacitances, load current of the oscillator tube, and the output voltage of the rig.

ing objects, or how high up-in-the-air you can get it.

As with most things, the most desirable antenna design is the simplest one you can construct that is consistent with reasonable performance. I recommend either one of these two well known types, the folded doublet and the 2-band end-fed wire.

### A One Band Antenna

If one band operation is desired, the antenna shown in Fig. 4, the half-wave doublet, has been in satisfactory use for years and years. Many commercial FM and TV, as well as commercial communication and ham stations, use this basic antenna design. It's quite easy to figure out the necessary length of wire to match the particular crystal frequency at which you are operating. For example, you want to operate on 40 meters and your crystal frequency is 7150 kc., the middle of the band. Follow these steps and you can cut the antenna wire to the length necessary to resonate with any ham crystal. In the formula:  $L = 468/f$  substitute the crystal frequency in megacycles for  $f$ .  $L$  then becomes the length of the antenna in feet. In this case  $L = 468/7.15$  or 65.45 feet.

For practical wire cutting purposes,

Bottom view of the transmitter chassis. Although the chassis measures just 3x5x1 $\frac{3}{4}$  inches there is a surprising amount of space available even after all of the parts have been wired into place.

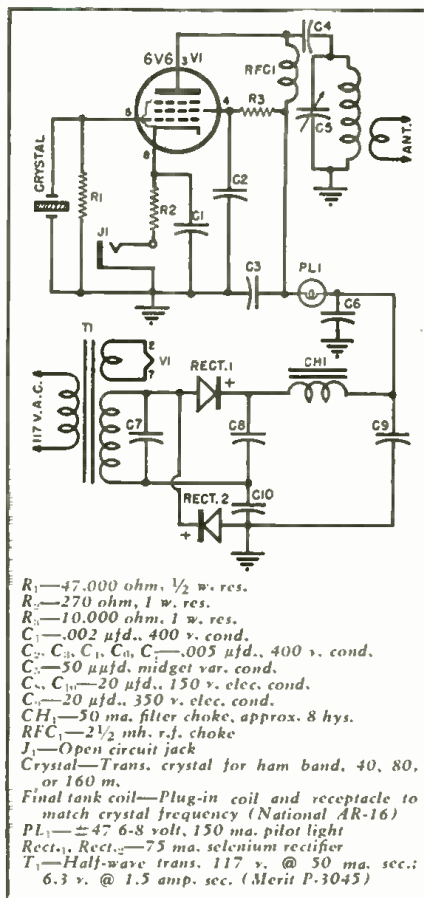
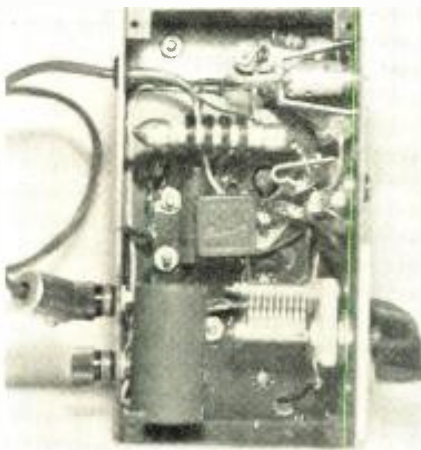
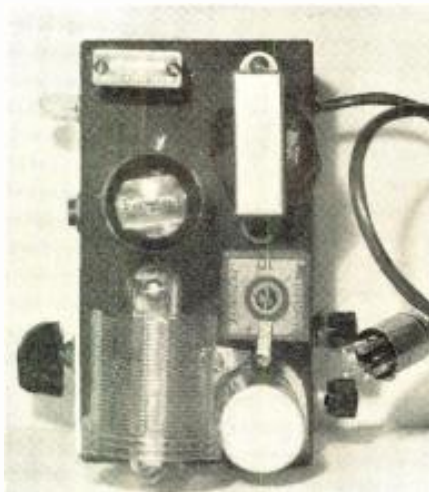

Fig. 3. Complete circuit diagram of the compact, 12-watt transmitter which can be built on a 3x5x1 $\frac{3}{4}$ -inch chassis.

65 $\frac{1}{2}$  feet is close enough. As shown in Fig. 4, split the 65 $\frac{1}{2}$  feet long wire at the midway point and trim 6 inches off each end of the two wires. Then, as in the diagram, form an insulated splice to join the two wires together. This is done by using two non-conducting antenna insulators and another short piece of wire between them, so measured that the entire splice section

(Continued on page 133)

Top view of rig shows efficient use of small space. In a line down the side are the filter choke, two selenium rectifiers, and the electrolytics. The crystal, tube, and coil are also visible in this photo.



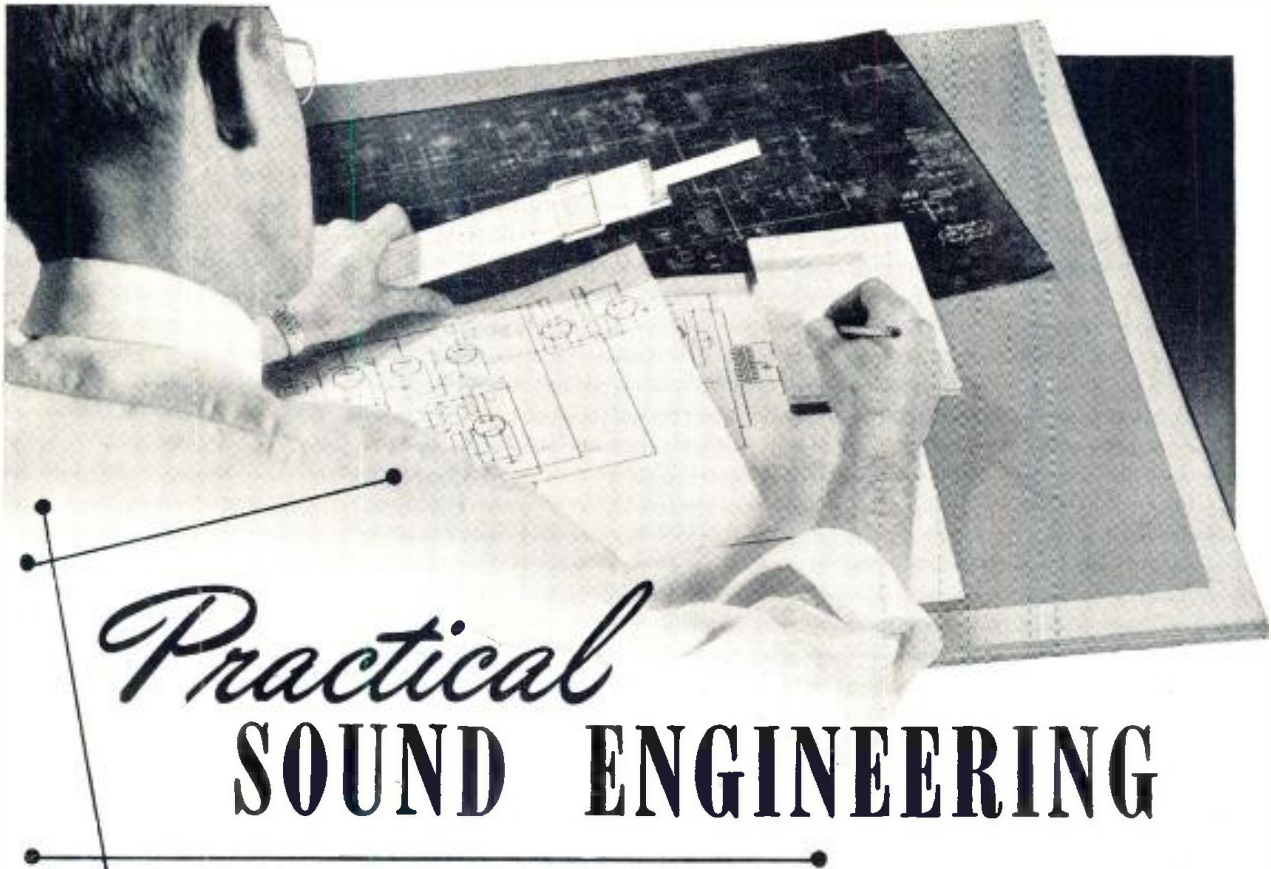

# Practical SOUND ENGINEERING

By

**H. M. TREMAINE, D.Sc.**  
College of Audio Engineering  
University of Hollywood

**Part 3. The decibel—its definition and how it is used as a convenient tool by the design engineer to calculate gains and losses in audio equipment.**

**I**N THE field of acoustics and sound engineering, the range of sound intensities or pressures is so great that it has been found necessary to establish a standard scale of units by which they might be gauged. As the human ear hears in a logarithmic manner, it was necessary for the scale of units to be a logarithmic function.

At an international convention of telephone engineers and other interested persons held in 1938, the "bel," so-called in honor of Alexander Graham Bell, was adopted as a standard unit of measurement, replacing the former "transmission unit" (tu.) used for the measurement of sound intensities.

The bel is equal to the common logarithmic ratio of two powers. When the ratio is 10/1, the powers differ by one bel. The decibel is the unit generally employed to express the magnitude of changes in sound intensity or signal level, and is 1/10 of a bel. The symbol for the decibel is db.

The decibel is most useful in audio design work and audio frequency measurements. In audio engineering large power ratios are reduced to numbers more convenient to handle. If the power at the output of a device is 10,000,000 times that at the input, the ratio is expressed simply as 70 db.

Gain and loss may be added or subtracted directly. In acoustic measurements, the decibel is used to express a change in the intensity level. The change in level can be expressed either in decibels or "volume units". A change of 1 volume unit (vu.) is equal to a change of 1 decibel. The term "volume unit" is generally used when speaking of complex waveforms comprising speech or music, or both. To use the decibel equation and its derivatives, a knowledge of logarithms is essential.

Logarithms are basically nothing more than an expanded system of powers of ten. The first step in taking the logarithm of a number is to express that number as a number between one and ten multiplied by the proper power of ten. Let us consider the number 278,000. This can be written as  $2.78 \times 10^5$ , and is as far as we go in a simple powers of ten operation, but in logarithms, we can go farther.

Let us now express the 2.78, also as a power of ten. Remembering that  $10^0$  is equal to 1 and that  $10^1$  is equal to 10, it is obvious that any number between 1 and 10 will have a corresponding power of ten between zero and one, and numbers between zero and one are decimals. The number 2.78 can be written as  $10^{0.444}$  and, consequently, the entire number can also be written as  $10^{0.444} \times 10^5$ . In multiplying such

numbers, we merely add exponents, which gives us  $10^{5.444}$  as the power of ten corresponding to the number 278,000. To convert this to a log, we merely neglect to write ten; thus:  $\log_{10} 278,000$  equals 5.444.

A logarithm is divided into two parts, the whole number (in this case 5) and the decimal part (.444). The whole number is called the "characteristic," and the decimal part the "mantissa." Observe that the characteristic is the power of ten used to express the original number as a number between one and ten, and the mantissa is the power of ten corresponding to the number as it was written. Mantissas are always decimals, and are obtained from a log table.

The characteristic is never printed in the log table, nor is it read on a slide rule. The characteristic is determined by the number of digits, *i.e.*, 0=units, 1=tens, 2=hundreds, 3=thousands, 4=ten thousands, 5=hundred thousands, 6=millions, 7=ten millions, 8=hundred millions, and 9=billions.

When a number is between 1 and 10, the characteristic is zero, because it will be between  $10^0$  and  $10^1$ . We can find the characteristic by writing the number in units and applying powers of ten. In doing so, the exponent of the power of ten will be the characteristic.

For example: 765,000 would be written  $7.65 \times 10^5$ . Its characteristic would be 5 or, given the figure 0.000765, written in powers of ten, we would have  $7.65 \times 10^{-4}$  and the characteristic would be -4.

The characteristic may also be determined by the application of one of the following rules:

**Rule One:** For numbers greater than unity, the characteristic is one less than the number of digits to the left of the decimal point.

**Example:** Consider the number 34. This number has two digits to the left of the decimal point, therefore, the characteristic is 1. The number 340 has three digits to the left of the decimal point; hence, the characteristic would be 2, etc.

**Rule Two:** For numbers less than unity, the characteristic is negative and one more than the number of zeros between the decimal point and the first significant digit.

**Example:** Consider 0.0403. There is only one zero between the decimal point and the first significant figure. Hence, the characteristic would be -2. Or, if we were given the figure 0.000403, we have three zeros between the decimal point and the first significant figure and the characteristic would, therefore, be -4, one more than the number of zeros between the decimal point and the first significant figure.

As has been previously stated, the fractional part of the logarithm is called the mantissa. All mantissas are positive. When a log has a negative characteristic, it is written  $\bar{3}$ . The minus sign above the characteristic indicates that the characteristic is negative. The mantissa, determined by the use of log tables, is always positive.

Thus far we have discussed the conversion of a number to a logarithm. We must now consider the conversion of a logarithm to a number, or an "antilog." When converting a log to a number, the first step is to read the mantissa from the log tables and then place the decimal point. The antilog is sometimes written as  $\log^{-1}$ , which simply means, antilog of the number. Suppose we were given the problem:  $\log^{-1} 3.6990$ ; find the number. Remember that the notation  $\log^{-1}$  indicates that the figure or figures following it are already a logarithm and must not be further converted into a logarithm.

Referring to a log table, we find the mantissa 6990 under the "0" column and opposite the "N" column figure of 50. Thus we know our resultant figure will be 50 something. The characteristic of 3 tells us that the number will be greater than unity (see Rule One) and because it is 3, the number, then, must be FOUR places to the left of the decimal point, or 5000.

Suppose, however, that the problem had read  $\log^{-1} 0.6990$ . The characteristic here is zero, indicating the number is greater than one and less than ten. The mantissa is the same, so we would arrive at the result that  $\log^{-1} 0.6990$

equals 5.0. Similarly, if the problem had read  $\log^{-1} .6990$  the result would be 0.05, since the characteristic of  $\bar{1}$  indicates one more than the number of zeros between the decimal point and the first significant digit, or the position of the first significant figure to the right of the decimal point.

#### Use of Decibels

Gain is defined as an increase of power and may be expressed in decibels. A reduction in power is considered a *negative* gain, and is expressed in decibels as a loss. The decibel is used to express amplifier gain, variations in frequency response, power output, and the intensity of sounds. It is also used to express the loss of attenuators and the frequency characteristics of equalizers, filters, and similar equipment. Very often a reference level is used in conjunction with such measurements.

The two reference levels in current use are 1 milliwatt and 6 milliwatts. The first reference level is based on the flow of 1 milliwatt of power in a 600 ohm circuit. The second reference level is based on the flow of 6 milliwatts of power in a circuit resistance of 500 ohms.

Equipment manufactured since 1938 is designed and calibrated for the 1 milliwatt reference level. The 6 milliwatt reference level was in general use prior to 1938 and is still being used by the majority of the motion picture studios in Hollywood. The 6 milliwatt reference level was adopted in the early days of telephony as a standard because it represented the amount of power required for satisfactory reproduction by the telephone equipment then in use. A number of years ago RCA introduced a 12.5 milliwatt reference level, which was used by the broadcasting and recording industries; however, this was later replaced by the 6 milliwatt reference level.

With the 1 milliwatt reference level came a new term, "zero-dbm," meaning that the power level under discussion is in relation to 1 milliwatt of power in a 600 ohm circuit. In the discussion of reference levels, the term dbm applies *only* to the 1 milliwatt reference level, while the term db is used *only* to express levels referring to the 6 milliwatt reference level.

The use of a 1 milliwatt reference level has its advantages. It is a unit quantity; hence, it is readily applica-

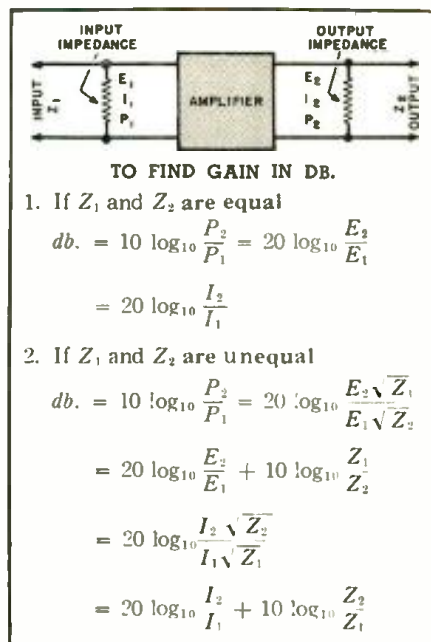

Fig. 1. Amplifier circuit and the formulas used to determine the gain of amplifier.

ble to the decimal system, being related to the watt by a factor of  $10^{-3}$ , which results in positive values for the majority of measurements.

When speaking of quantities above the reference level, it is said to be "n" db. above, and then referring to levels below, "n" db. below.

The gain of an amplifier is positive because it amplifies the signal and increases its amplitude. Other devices, such as mixer networks, filters, equalizers, and attenuators all produce a loss when inserted in a circuit, and result in a reduction of power at their outputs.

In the general decibel equation, we make use of a ratio between two powers, one of which may be a fixed reference level. In the calculation of gain or loss, the power at the output of a device is compared to the power at its input. When the decibel is used in this sense, there is no fixed reference level.

The second most common application of the decibel is the expression of power at some point in a system. The equation for this expression requires the use of two powers and their ratios. For the second power we use the standard reference level, and state it along with the level in decibels.

If it is stated that the level at some

Table 1. How widely divergent ratios may be calculated by inspection.

RATIO	Log <sub>10</sub> of RATIO	DB. for POWER RATIO	DB. for I or E RATIO
.0001	-4	-40	-80
.001	-3	-30	-60
.01	-2	-20	-40
.1	-1	-10	-20
1.	0	0	0
10.	1	10	20
100.	2	20	40
1000.	3	30	60
10000.	4	40	80
100000.	5	50	100
1000000.	6	60	120

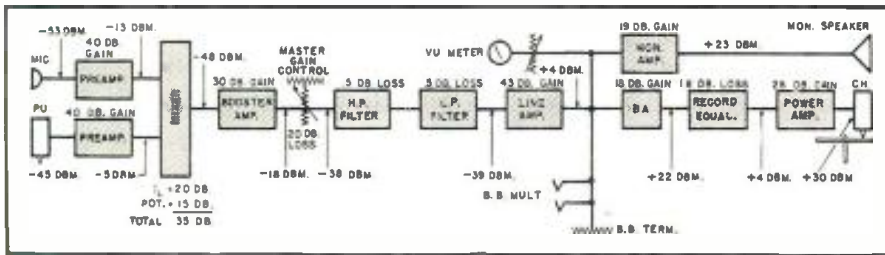

Fig. 2. Block diagram of a recording system illustrating range of levels encountered.

point in a recording system is plus 30 db., it means that the power at that point is 30 db. above the reference level, and expresses the power at that point with respect to the reference level.

A db. gain or loss may be used to express the ratio between the output and the input power of a device, and is indicative of the amount of amplification or loss in power of the signal, after passing through the device. This ratio is expressed by multiplying the logarithm of the power ratio by 10.

Amplifier gain is always stated simply as "n" db. gain. Quantities expressed in decibels may be added or subtracted, but never multiplied. Thus, if two amplifiers of 20 db. gain are connected in cascade or tandem, the total gain for the two is 40 db.

To prevent confusion as to which reference level has been employed in the rating of equipment, we express the power level in "db." for the 6 milliwatt reference level, and for the 1 milliwatt level, we use the term "dbm." (the *m* meaning milliwatt), to remind us that the statement is with respect to the 1 milliwatt reference level. The method of calculation is the same when using either reference level, except for the powers.

It is frequently of interest to know the voltage in a circuit represented by these reference levels. The voltage may be determined by the use of equation (1).

$$E = \sqrt{PZ} \dots \dots \dots (1)$$

where: *P* equals the power in watts and *Z* the circuit impedance, in ohms.

Using equation (1) we find that the voltage for 1 milliwatt of power in a 600 ohm circuit is 0.773 volt and for 6 milliwatts in a 500 ohm circuit 1.73 volts.

For power levels expressed in db. and dbm. there is a *fixed* relationship between the levels. It is obvious that, for a given amount of power, the numerical value of db. will be greater for the 1 milliwatt reference level than for the 6 milliwatt reference level. This difference is 7.78 db. Therefore, a

plus 10 db. is equivalent to a plus 17.78 dbm. This difference between the reference powers may be found by equation (2).

$$db. = 10 \log_{10} \frac{P_1}{P_2} \dots \dots \dots (2)$$

Substituting in equation (2);

$$= 10 \log_{10} \frac{6}{1} = 6$$

$$10 \log_{10} 6 = 10 \times 0.778 = 7.78 \text{ db.}$$

This same equation may also be used to find the output level of an amplifier in db., although the output level is quoted in watts. As an example: assume we have an amplifier which is stated to have an output power of 10 watts. What is the equivalent in dbm.? Using equation (2) and the 1 milliwatt reference level:

$$db. = 10 \log_{10} \frac{P_1}{P_2}$$

$$= 10 \log_{10} \frac{10}{0.001} = 10.000$$

$$10 \times \log 10.000 = 10 \times 1 = 40 \text{ dbm.}$$

Because this represents a power greater than the reference level, we place a plus sign in front of the 40, thus the output level is plus 40 dbm. If the output was taken with respect to the 6 milliwatt reference level, the output would be a plus 32.22 db. It is now easy to see how an amplifier rated in db. could be very easily overloaded if an attempt were made to obtain an output level equivalent to that for the 1 milliwatt reference level. It is important to remember that every time the output level is increased 3 db., the output power must be doubled.

In both the examples thus far the greater power was placed in the numerator; naturally, the result will always be greater than unity, and the characteristic of the log will be zero or a plus quantity. In this way negative characteristics are avoided. Since it is known if the device has a gain or loss, it is only necessary to place the proper sign before the resulting answer.

When two values of voltage or cur-

rent are to be compared, the logarithm is multiplied by 20 instead of 10, as the power varies directly as the square of the current. Doubling the log is equivalent to squaring the number. Therefore, for problems involving current or voltage, the equations (3) and (4) are used.

$$db. = 20 \log_{10} \frac{E_2}{E_1} \dots \dots \dots (3)$$

$$db. = 20 \log_{10} \frac{I_2}{I_1} \dots \dots \dots (4)$$

where: *E*<sub>1</sub> equals the input voltage and *E*<sub>2</sub> the output voltage and *I*<sub>1</sub> and *I*<sub>2</sub>, the input and output currents.

One precaution must be observed when using equations (3) and (4); they may *only* be used when the input and output impedances are equal in value. If the impedances are unequal in value, equations (5) and (6) are substituted.

$$db. = 20 \log_{10} \frac{E_2 \sqrt{Z_1}}{E_1 \sqrt{Z_2}} \dots \dots \dots (5)$$

$$db. = 20 \log_{10} \frac{I_2 \sqrt{Z_2}}{I_1 \sqrt{Z_1}} \dots \dots \dots (6)$$

A typical example of how the gain of an amplifier with unequal input and output impedances is calculated, is given below using equation (5). Assume we have an amplifier with an input impedance of 250 ohms, and an output impedance of 500 ohms. The signal voltage at the input is 0.005 volt and the signal voltage at the output is 5.0 volts. What is the gain in db.?

$$\begin{aligned} db. &= 20 \log_{10} \frac{E_2 \sqrt{Z_1}}{E_1 \sqrt{Z_2}} \\ &= 20 \log_{10} \frac{5 \times \sqrt{250}}{0.005 \times \sqrt{500}} \\ &= 20 \log_{10} \frac{5 \times 15.8}{5 \times 10^{-3} \times 22.4} = \frac{79.0}{112 \times 10^{-3}} \\ &= 20 \log_{10} 705 = 20 \times 2.8482 \\ &= 56.96 \text{ db.} \end{aligned}$$

A problem that often arises in the design of audio amplifiers is: What will be the effective increase or decrease in the gain of an amplifier using an input transformer with an impedance ratio of 500 to 100,000 ohms, as compared to a transformer with an impedance ratio of 500 to 60,000 ohms, for the same level input signal.

First, we must know the turns ratio of the transformers. Turns ratio is equal to the square root of the impedance ratio. For the first transformer:

$$\text{Turns Ratio} = \sqrt{100,000/500} = \sqrt{200} = 14.14$$

For the second transformer:

$$\text{Turns Ratio} = \sqrt{60,000/500} = \sqrt{120} = 10.95$$

Substituting in equation (3);

$$db. = 20 \log_{10} \frac{14.14}{10.95} = 1.292$$

$$20 \times \log_{10} 1.292 = 20 \times 0.111 = 2.22 \text{ db.}$$

Therefore, if we substitute the second transformer and match the input (Continued on page 143)

Table 2. Gains and losses in a sound system and how they are added to attain over-all gain.

LOSSES		GAINS	
Mixer	35 db.	Misc. preamp	40 db.
Master gain	20 db.	Booster ampl.	30 db.
Filters	1 db.	Line ampl.	43 db.
Rec. equal	18 db.	Bridg. ampl.	18 db.
		Rec. ampl.	26 db.
<b>Total loss</b>	<b>74 db.</b>	<b>Total gain</b>	<b>157 db.</b>
		<b>Total gain</b>	<b>157 db.</b>
		<b>Total loss</b>	<b>74 db.</b>
		<b>NET GAIN</b>	<b>83 db.</b>



# International SHORT-WAVE

Compiled by **KENNETH B. BOORD**

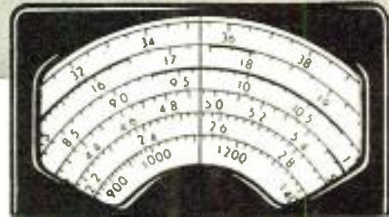

**T**HIS month it is a pleasure to dedicate the *ISW DEPARTMENT* to stations in widely-separated corners of the earth—namely, ELBC, Monrovia, Liberia, in Africa, and YNDG, Leon, Nicaragua, in Central America.

This information concerning ELBC came direct from Dr. John B. West, president, the Liberian Broadcasting Company, Monrovia, Liberia, which is the QRA for reports.

ELBC, the initial outlet of the Liberian Broadcasting Company, went on the air from its studios in Monrovia on May 2, 1950, transmitting with 1 kw., using a folded dipole antenna, on 6.025. The station broadcasts each night at 1945-2345 GMT (1445-1845 EST). Program material consists of popular, classical, folk, and children's music, children's stories, dramatic presentations, news and advertisements in *English*; and music, news, and advertising in Arabic and French.

Personnel includes a radio engineer, two radio technicians, two *English*-speaking announcers, an Arabic-speaking announcer, and a French-speaking announcer, as well as a musical librarian and stenographic help.

One of the most popular programs of ELBC is at 1515-1545 EST under the title "Children's Corner, with Uncle John;" another is "Listeners' Choice," directed by disc-jockey Richard Prees, at 1745-1845 each Saturday evening. The children's program is daily and includes music, education, and folk tales, as well as other famous types of children's stories of educational value.

At present, ELBC transmits for the "Voice of America;" *Sears, Roebuck and Company* of Philadelphia, Pennsylvania, and *RCA International* of the United States, and for such local (Liberian) firms as *National Manufacturing Company* and *National Drug Company*. Negotiations are in progress with 11 other American firms for advertising contracts, and with six firms in Great Britain.

"We will readily verify any correct logs reported to us in writing," says Dr. West, "and will reply negatively in writing to those that are incorrect. We will pay the postage."

At the time this was compiled, plans were being drawn for a new studio-transmitter building to house two new transmitters on shipment to Liberia. Each of the new transmitters is 1 kw. and will be coupled with new high-

fidelity audio equipment and studio console. One will be used with a North-South high-gain directional antenna, and the other on a similar East-West antenna. The present transmitter will continue on a non-directional basis for radial coverage of the immediate surrounding area. New frequencies were yet to be assigned by the Liberian Chief of Communications, but will be in the 25- and 19-m. bands, respectively. *By this time the new transmitters may be in operation. I hope to have further details soon.*

ELBC also was drafting plans for "Learn English by Radio" which will carry education to the hinterland of Liberia; this probably will be effected in July or August of this year, and will be radiated during (local) daytime.

Just recently, ELBC has been coming through fair to good in the United States, probably due to more favorable seasonal propagation conditions approaching the optimum between Liberia and this country, and/or re-

cently-effected improvement of coupling the transmitter to the antenna. Reception here in West Virginia normally is best towards closedown (1845 EST which is 2300 Liberian Time), and signal strength, quality, and QRM vary from day to day. Frequent announcements are noted and the station is easy to identify.

And direct from Dennis E. Gallo, manager, D. E. Gallo & Co., operator of Radio Colonial, YNDG, 5.995, Leon, Nicaragua, comes this interesting data:

YNDG began operations on April 1, 1938, on a frequency of 7.660 in the 39-meter band. Power was 100 watts, using a 35T on final, modulating with a pair of TZ20's. In 1947, the present rig—a *Hallcrafters* BC-610 E—was bought from the U.S. Government. It is a 250 watt transmitter. In February 1950, power was increased to 1 kw., using a new final with two 250TH tubes and a new power supply with two 866 tubes using 2400 volts and 350 mils on final. The old final of the rig, a 250TH, is a driver now with 60 mils; 100 mils on grid of final, also a new modulator transformer was installed to take care of the increased power.

On January 1, 1951, a new frequency was assigned by the Nicaraguan government—5.995, YNDG is on the air daily 1700-2300.

(Continued on page 110)

**YNDG, 5.995, Radio Colonial, Leon, Nicaragua, uses a Hallcrafters BC-610E. Since this photograph was taken the station's power has been increased to 1 kw. and additional equipment has been added. Dennis E. Gallo is the manager of this outlet.**



# Adapt Your Amplifier for MAGNETIC RECORDING

By  
**LLOYD B. HUST**

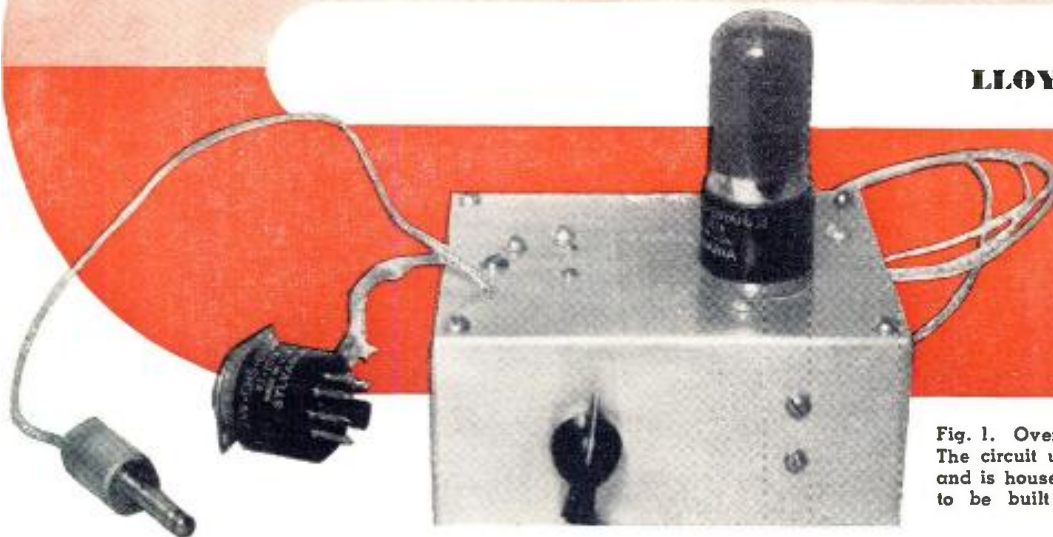

Fig. 1. Over-all view of the adapter unit. The circuit uses one tube and few parts and is housed in a chassis small enough to be built into the amplifier cabinet.

**Construction details on an ultrasonic oscillator that can be used with your audio amplifier for recording and erasing on magnetic tape or wire.**

IT IS a well-known fact that the ordinary amplifier is not suitable for magnetic recording unless it is especially adapted for this service. In fact, early experiments in magnetic recording were discontinued because, although magnetic impressions could be placed on the recording medium by feeding the output from a standard amplifier into an electromagnetic type of recording head, the recorded signal was of low amplitude, low signal-to-noise ratio, and of extremely high distortion. One reason for this is the non-linear relationship which exists between a constant-current recording signal and the magnetization characteristics of the permanent magnetic recording material. Experiments showed that the application of a d.c. bias voltage to the recording medium during recording would somewhat improve the amplitude and quality of the recorded signal, but the problem of low signal-to-noise ratio remained. The substitution of an ultrasonic a.c. bias for the d.c. bias helped greatly to overcome this difficulty. This mixing of this ultrasonic frequency with the audio signal being recorded usually takes place in the recording head, with both voltages being fed into the head simultaneously.

If the audio signal from an ordinary amplifier is fed into a recording head along with an alternating voltage of from 25 to 50 kc., the signal impressed upon the recording medium, be it tape

or wire, will result in a magnetic pattern, which, upon playback through the same amplifier will result in a frequency response curve somewhat similar to that shown in Fig. 2. It will be seen from this curve, that for maximum fidelity, or for a "flat" recording and playback characteristic, the recording and/or playback amplifiers must be equalized at both the high and low frequency ends of the audio spectrum. Probably the most efficient method of equalizing to achieve a relatively flat response in magnetic recordings is to pre-emphasize the high frequencies and to post-emphasize the low frequencies, or possibly even both high and low frequencies. This method minimizes the possibility of over-recording or overloading the medium which would be likely to occur if the low frequencies were boosted during the recording cycle.

The modern recording amplifier, therefore, differs from the ordinary amplifier principally in two respects; first, in the incorporation of a source of high frequency bias current, and second, in the provision of equalization networks—high boost circuits for the recording cycle and high and low boost circuits for the playback cycle. Often this amplifier will also supply an ultrasonic voltage suitable for erasing a previously recorded signal.

Many experimenters would like to use their present amplifiers for magnetic recording. The adapter herein

described will make this possible at a minimum of cost and with no internal changes required in the amplifier. The adapter is essentially an oscillator capable of supplying the necessary ultrasonic bias for recording and erasing of recorded signals. It is so constructed that it can be connected to the amplifier or disconnected in just a few moments. A switch is incorporated to connect the proper portion of the amplifier to the recording head and to disconnect the plate voltage from the oscillator tube while a record is being played so that the signal will not be erased. A separate switch is used to disconnect the lead from the plate of the amplifier when playing back a recording so that regenerative feedback will not occur.

This unit will work well with most of the high impedance heads now on the market. The erase voltage developed by this unit is sufficient to energize most low impedance erase heads. Very good results were obtained using the adapter with a *Shure Model 815* head designed for tape recording. This head is a combination record-playback and erase head. The constructor may wish to use some other head, however, and any high impedance recording head will work well with this unit. A low impedance recording head will also work well, but in case such a head is used, the voltage from  $L_1$  will have to supply the head with its bias voltage and the audio voltage will have to come from the secondary of the output transformer used in the amplifier. The fact that this unit can be used with practically any kind of head makes it a very versatile device.

The schematic diagram for the adapter is shown in Fig. 4. The oscillator coil  $L_1$  and  $L_2$  should be con-



constructed as follows: The first half of  $L_1$ —100 turns of #25 enameled wire—is layer wound upon a form  $\frac{1}{2}$ " in diameter and  $2\frac{1}{2}$ " long. ( $\frac{1}{4}$ " of this length is taken up by the actual windings) The ends of the form should be equipped with fiber washers so that the coil, when finished, will be as nearly cylindrical as possible.  $L_2$  is wound directly over the first half of  $L_1$  and is insulated from it by a layer of varnished cambric. (Heavy waxed paper will be suitable if the cambric is unavailable.)  $L_2$  consists of 1000 turns of #30 enameled single cotton-covered wire and is tapped at the 275th turn. It may be difficult to wind this coil in even layers and "scramble" winding will be satisfactory if the coil is kept as cylindrical as possible. This winding should be covered with an insulating layer and the second half of  $L_1$  is wound over it. This consists of another 100 turns of #25 enameled wire. The starting end of the second half of  $L_1$  is connected to the finish end of the first half and both halves should be wound in the same direction.

The chassis used should be deep enough to house the coil and other components and a bottom plate should be employed to minimize radiation. (The chassis used by the author measured 4"x5"x2" deep). If these precautions are not taken, harmonics of the output of the oscillator may beat against the station carrier wave in an associated radio set, creating undesirable interference.

Pin jacks are used to connect the wires from the record-playback head and the erase head (or sections of the same head). Shielded wire is used and the connectors should make positive contact with their sockets. The lead to the input of the amplifier should be shielded and should be equipped with a connector which will fit the microphone input of the amplifier used. The lead to the plate of the output tube *must* be shielded or much difficulty will ensue. In general these leads should be kept as short as possible.

The connections to the amplifier, which are made to supply filament and plate power as well as to supply the audio voltage to the adapter, are made through a plug-socket connector which is plugged into the socket of one of the output tubes of the amplifier and into which the amplifier output tube is plugged. Fig. 3 shows how this connector is assembled from the base of an octal tube and an octal socket. A  $\frac{3}{8}$ " hole is drilled in the side of the tube base and the leads from the oscillator are taken through this hole. They are soldered to the appropriate socket pins—filament leads to pins 2 and 7, plate lead to pin 3, "B+" lead to pin 4. Then a flexible lead is made from each socket terminal to the corresponding pin in the tube base. The connections indicated are for the beam power type of tube, such as 6V6 or 6L6 with which most amplifiers are equipped. If the amplifier to be used does not use this type of output tube, it may be necessary to wire in a special connector to

the amplifier so that the proper voltages can be obtained. The "B—" lead and the shield on the wire connecting to the plate of the output tube should be connected to the amplifier chassis with a clip.

Since different amplifiers may have different voltages present at the output tubes, the value of  $R_2$  may have to be changed to compensate for this difference. The voltage at the plate of the 6V6 should be in the neighborhood of 275, although the value is not critical. In order to develop sufficient voltage for some erase heads it may be necessary to raise this voltage some. Raising it above 300 volts will have a tendency to cause the oscillator to deliver a distorted wave rather than the true sine wave which is necessary if distortion-free recordings are to be obtained.

The record-playback head receives its audio voltage directly from the plate of the output tube of the amplifier through a .25  $\mu$ fd., 600 volt condenser in series with a 25,000 ohm,  $\frac{1}{2}$  watt resistor. The return lead of this head is to ground. The bias voltage is fed into this head through a 150  $\mu$ fd. mica condenser directly from the plate of the oscillator tube. The erase head receives its voltage from the secondary winding ( $L_1$ ) of the oscillator coil.

Probably the most difficult problem in the construction of this unit is that of eliminating any regenerative feedback from the output to the input of the amplifier. This problem is brought about because it is necessary to bring the output and input leads fairly close together so that the proper circuit can be switched into the record-playback head. The switch  $S_2$  is not a part of the rotary switch  $S_1$ , because of the possibility of feedback.  $S_2$  is a toggle switch which is located as shown in the diagram of the chassis. This arrangement minimizes the likelihood of feedback.

The condenser  $C_6$  resonates with the head when it is used for playback. This gives the necessary high boost.

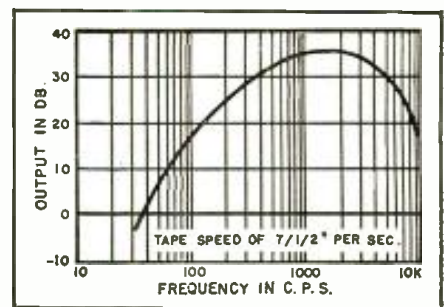

Fig. 2. Unequalized response of magnetic tape.

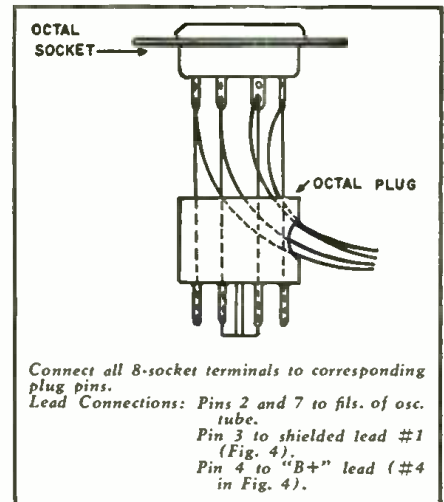
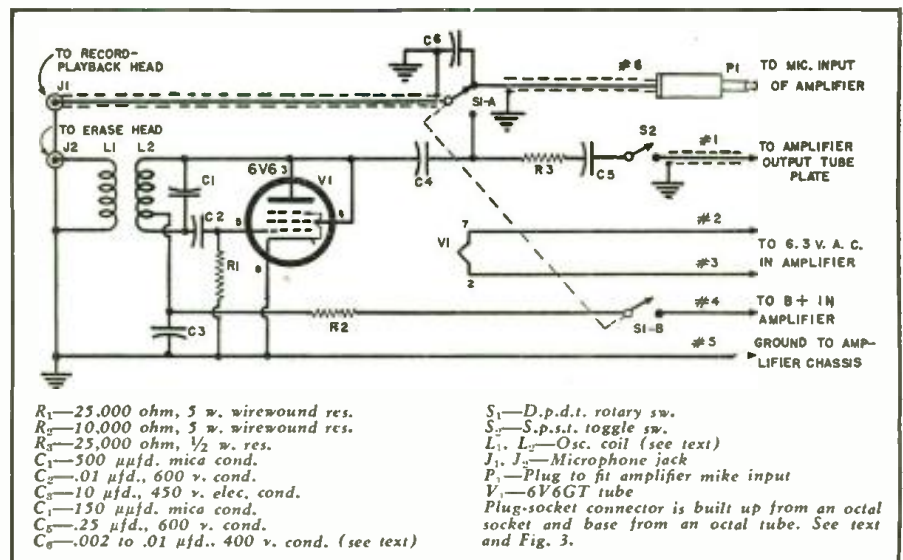

Fig. 3. Construction of plug-socket unit.

The value of this condenser varies with individual heads, and will range from .002 to .01  $\mu$ fd. However, a condenser of .005  $\mu$ fd. will give good results with most heads. For best high frequency boost, different values for  $C_6$  should be tried. In order to eliminate any changes in the amplifier being used, no other equalizing circuits are shown. Since most amplifiers are equipped with tone controls, the proper use of these controls will enable the operator to record and playback a signal with it flat over a wide (Continued on page 118)

Fig. 4. Complete schematic diagram and parts list for the magnetic recording adapter.



# Mac's RADIO SERVICE SHOP

By JOHN T. FRYE

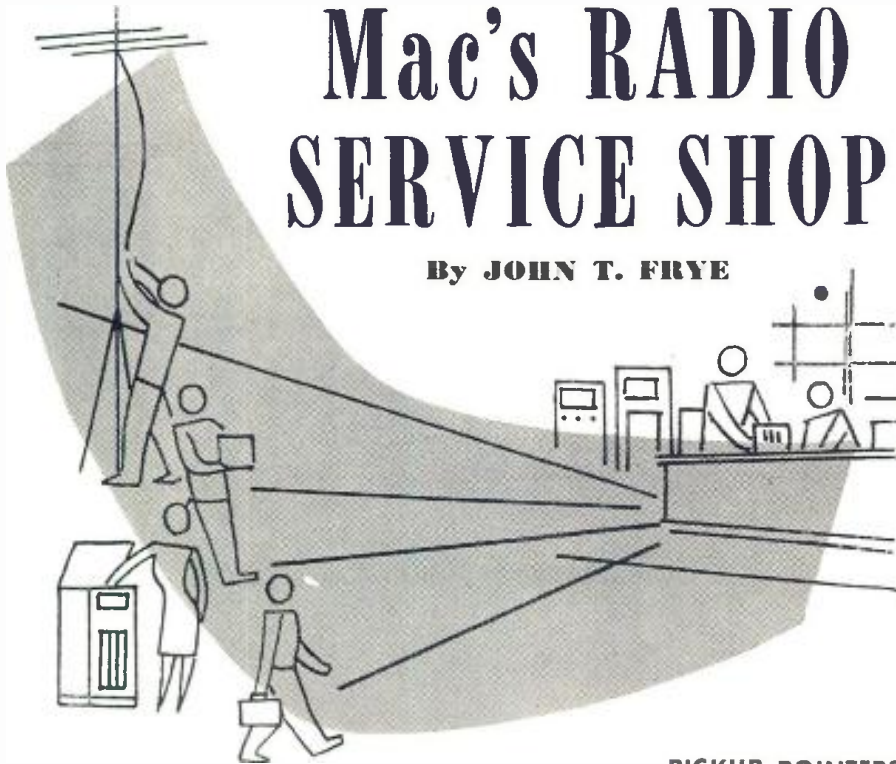

## PICKUP POINTERS

"HEY, Chief," Barney called to Mac, "bend an ear to this sour-sounding combo, will you? Seems all okay on the radio, but it's strictly from hunger on the platters. Suppose it could be the crystal cartridge? I checked the output of the pickup with the v.t.v.m., and it peaks right up to the rated two-and-a-half volts, without any jerking of the meter pointer like you get with a cracked crystal; but just listen to the awful things it is doing to the voice of 'liltin' Martha Tilton.'"

Mac lifted the tone arm from the record and looked at the crystal; then he sauntered to the back of the radio and record-player combination and took a long look at the wiring at the rear of the chassis.

"The equipment is all right," he said, "but the outfit is suffering from what guys in the service call 'cockpit trouble,' meaning 'fouled up by the operator.' Originally that tone-arm carried a beam-of-light pickup system, and the very low output of the light cell was amplified by a high-gain amplifier running wide open. During the war it became impossible to get light cell replacements, and a technician has changed this one over to a crystal cartridge. The idea is good, but the method is wrong. The full output of the crystal cartridge is run straight into the amplifier, feeding it ten or twenty times as much signal as it was designed to handle. The result is the heavy overloading and distortion that you hear."

"Well, what's to do about it?"

Before answering, Mac slid a drawer out of a steel filing cabinet and rifled through the index cards. Then he pulled out a mimeographed sheet and sailed it across to Barney. "Rewire the

phono and microphone inputs according to this diagram," he told the youth. "That attenuator network (see Fig. 1) will make the pickup do justice to Martha's voice."

Barney looked at his employer quizzically. "I'm wondering how it always 'just happens' that you have the information on tap for licking nearly every problem I bring up," he said slowly. "For instance, how did you come by this diagram?"

"Elementary, my dear Watson," Mac replied cheerfully; "I sent for it. You may have noticed that I study radio magazines, house organs, advertising pamphlets, etc. received here at the shop almost as thoroughly as you go over *Esquire* cartoons. When I see a manufacturer is offering an informative brochure on some subject in connection with radio or television, I send for it, read it, and file it away for future reference. On top of that, when I run across something that puzzles me in service work and which I cannot answer by myself, I don't hesitate to call

Fig. 1. Astatic Corporation's crystal replacement for a Philco photoelectric unit.

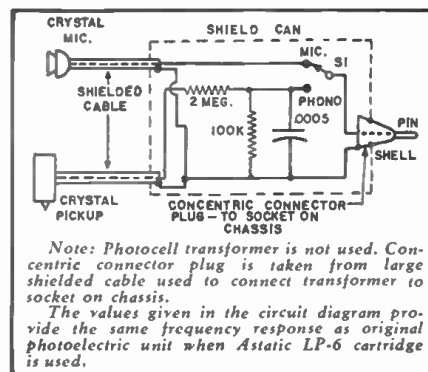

for help by writing to the company that made the puzzling gadget. You'd be surprised how much time and trouble a big manufacturer will go to in order to help you do a better service job on his products. That cabinet is stuffed with letters from company engineers."

"While I'm changing over this pickup, and while my mind is on the subject, why don't you go through that file and give me some more good hot dope on the phonograph cartridges," Barney suggested.

"Okay," Mac agreed as he pulled a fat file from the cabinet; "but just remember you asked for it. For instance, did you know that a Rochelle salt crystal cartridge has its greatest output at 70 degrees, Fahrenheit, and that will function normally and have a very long life under temperature and humidity conditions most comfortable to human beings? Seventy to eighty degrees and a relative humidity of fifty per-cent is just right for people and crystal cartridges."

"The tropics must be kind of hard on the cartridges," Barney's muffled voice said as he lay on his back with his head inside the speaker compartment of the combination.

"They are. In the daytime tropical temperature and humidity are both high. At night the temperature may drop 50 degrees while the relative humidity remains high. The effect on the hygroscopic cartridge is to make it practically suck water into itself. The moisture lowers the resistance of the crystal element, causing a reduction in output and a change in frequency response most noticeable as a loss of low frequencies. Eventually, enough moisture will ruin the crystal either by dissolving it or by promoting fungus growth that accomplishes the same end."

"Any way of licking the problem?" Barney asked as he vigorously shook excess solder from the tip of his solder gun.

"There are some partial solutions. Crystal cartridge manufacturers use every known method to waterproof their products. Some of them make up special humidity-proofed units for use in the tropics. None of these measures, however, will completely prevent hydration; but they help a lot in slowing up the process and extending the life of the crystal.

"There are some things the cartridge-user can do to help. One thing is to keep a low-wattage bulb burning inside the radio cabinet near the crystal. This will keep the temperature fairly even and will dry some of the moisture from the atmosphere. The trick is to make sure the temperature of the crystal never goes above 110 degrees. The melting point of Rochelle salt is just slightly above 120 degrees, and the closer the cartridge is operated to this temperature, the shorter will be its life span.

"Another practical solution, especially with plug-in type cartridges, is

(Continued on page 99)

# SQUARE-WAVE TESTING SPEEDS TV SERVICING

By LOUIS E. GARNER, JR.



Fig. 1.

Fig. 2.

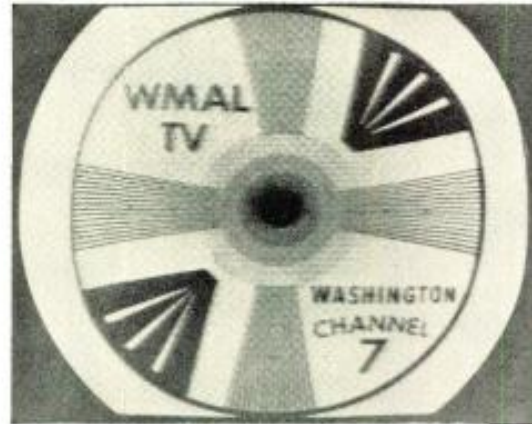

**A**S LONG as the test pattern is clear and sharp in a TV receiver and the lines of the vertical wedges can be clearly distinguished down to the center circle, it may be safely said that all signal circuits in the receiver are operating normally (see Fig. 1). If the picture quality deteriorates, the definition may suffer (Fig. 2) with the result that the lines "fade out" before reaching the central circle.

This condition (Fig. 2), may be caused either by defects in the video i.f. stages, or by defects in the video amplifier following the 2nd detector. The technician, upon encountering these conditions, may immediately assume that the trouble is in the video i.f., then spend from 30 minutes to an hour carefully realigning the i.f., only to find that the condition still exists. Or he may assume the trouble to be in the video amplifier, then spend considerable time trying substitute parts and checking plate and screen voltages in the video amplifier circuits.

However, by using a square-wave generator and easily applied test techniques, the average technician may, within only a few minutes, definitely find whether the trouble is in the video amplifier or not. He may then continue the same technique to isolate the trouble to a stage or part, or, if the video amplifier is shown to be clear of defects, concentrate on the video i.f. with

*Not a new technique but one that will provide a faster and more accurate method of servicing.*

full assurance he has isolated the trouble.

The basic connections necessary for the equipment used in applying this time-saving test technique are shown in block diagram form in Fig. 3. Actual connections are shown schematically in Fig. 4, where a part of the video amplifier circuit for the popular RCA 630TS TV receiver is used as an example. In practice, connections to and from the square-wave generator and to the cathode-ray oscilloscope are kept as short as possible. Open leads should be used unless shielded connections are necessary to minimize stray hum pick-up. If

a "low-capacity" probe is available for the oscilloscope, this should definitely be employed to prevent undue capacity loading of the 2nd video amplifier stage.

Several square-wave generators are available and all are generally satisfactory for carrying out the test techniques to be described. The generator should, however, at least meet the following basic requirements:

1. It should be able to supply both low and high frequency square-wave signals (50 c.p.s., 1 kc., or 10 kc., 100 kc., and 500 kc. or 1 mc.).
2. The square-wave signals supplied should have short rise time (maximum tolerable for high frequency signals is .1 microsecond).
3. Low output impedance (not over 600 ohms).
4. Control over output. Should be able to adjust output from several volts to under 1 volt.
5. The signals supplied should be free from overshoots and tilt at all frequencies within its range.

Any standard cathode-ray oscillo-

Fig. 3.

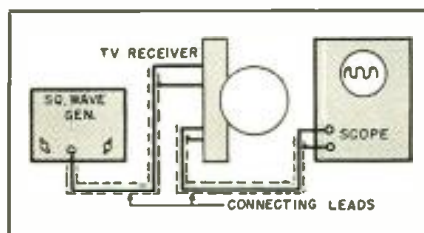

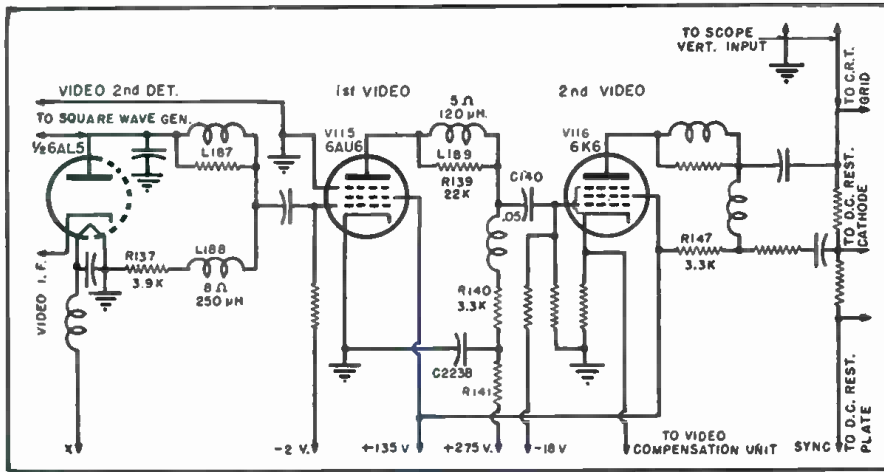

Fig. 4

scope may be used, provided it has good vertical response characteristics and has a sweep permitting at least two or three cycles of any of the square wave signals used in testing to be observed. For checking video amplifiers, the vertical amplifier of the scope should be reasonably flat ( $\pm 3$  db.) to 5 mc., should be free of overshoots, and should not introduce tilt in a 50 c.p.s. square wave.

If you do not know the characteristics of your scope, it may be checked by connecting the square-wave generator directly to the vertical input terminals and observing high and low frequency signals. The square waves should retain their "perfect" form, should not exhibit overshoots, and should not be rounded or tilted at frequencies of 50 c.p.s. 10 kc., 100 kc., or 500 kc.

#### Square-Wave Testing

Square-wave testing techniques have been described briefly in an earlier article<sup>1</sup>, and general information concerning analysis of the square-wave signals was given then. However, a brief review may be of value at this point.

Referring to Fig. 5A, a "perfect" square wave (3) may be considered to be made up of a sine wave (1), plus third (2) and higher odd harmonic signals, but of decreasing amplitude. The "body" of the square wave and its flat top are due primarily to the lower frequency signals, while the sharp leading and trailing edges are due to the higher frequency harmonics.

If there is a loss of lower frequency signals, or phase shift with respect to the higher frequency harmonics, the flat top of the square wave may be "tilted" and may even be concave as shown in Fig. 5B. A boost at frequencies near the fundamental of the square wave may result in a tilt in the opposite direction and in a convex top.

A loss of higher frequency signals results in "rounding" of the leading edges as in Fig. 5C, while accentuation or peaking at higher frequencies may

result in damped oscillations and "overshoots" as in Fig. 5D.

#### Troubleshooting

To prepare the following data, the author used an RCA 630TS television receiver, a Tektronix type 105 square-wave generator, and a Tektronix Model 511AD cathode-ray oscilloscope. However, since video amplifiers used in different TV receivers are essentially of the same form, the data obtained may be considered general, and will serve as a guide when servicing any TV receiver. Similarly, any test equipment meeting the general specifications outlined will be suitable for carrying out the test technique.

Defects were actually introduced in the TV receiver to cause complaints similar to those illustrated in Fig. 2, but in varying degree. Square-wave test techniques were then applied, and the resulting waveforms carefully traced.

**Normal:** Before introducing any defects, square-wave signals of 50 c.p.s., 10 kc., 100 kc., and 500 kc. were introduced in the video amplifier and output waveforms observed, to obtain the "normal" response of the video amplifier (Fig. 4). The waveforms obtained are illustrated in Fig. 6 (A to D). A 50 c.p.s. signal was tilted slightly, as shown in Fig. 6A. The 10 kc. square wave (Fig. 6B) was almost "perfect" except for a slight overshoot and "wriggle" on the leading edge, indicating the effect of the peaking coils. This is shown further by the 100 kc. square wave and the 500 kc. square wave, Figs. 6C and 6D, respectively. At these frequencies, however, "rounding" appears due to the drop-off in high frequency response.

**$C_{223B}$  increased in capacity:** A 10  $\mu$ f. electrolytic condenser was shunted across  $C_{223B}$ , (Fig. 4) doubling its effective capacity. No change occurred in the 10 kc., 100 kc., and 500 kc. signals. The 50 c.p.s. signal was tilted slightly more, but not appreciably. This simply indicated insufficient low-frequency compensation. Such a condition would probably not be noticed in the majority of TV receivers.

**$C_{223B}$  decreased in capacity:** When

$C_{223B}$  was removed from the circuit and a .5  $\mu$ f. condenser substituted, simulating a decrease in capacity or a partially open condenser, it was again found that the 10 kc., 100 kc., and 500 kc. square-wave signals were not changed. However, the 50 c.p.s. signal was changed appreciably and appeared as in Fig. 6E. This indicates peaking at a low frequency, and would affect a picture by preventing rapid changes in shade over large areas of the picture. Thus a scene with a light background and dark foreground would appear as gray fading to light followed by gray fading to black rather than as sharp whites and blacks.

**$C_{223B}$  open:** An open in  $C_{223B}$  was next shown by removing this condenser completely from the circuit. This effectively made  $R_{141}$  part of the plate load for the 6AU6. When this was done, it was found that the amplitude of the output signal became much higher for the same input and that a ripple appeared along the top of the 50 c.p.s. square wave, as shown in Fig. 6F. Apparently  $C_{223B}$  also serves to remove some hum and this appears superimposed on the square wave. The 10 kc. signal appeared normal, except that the slight "wriggle" on the leading edge disappeared. Both the 100 kc. and 500 kc. square waves were rounded, as shown in Figs. 6G and 6H, respectively, indicating a severe loss of higher frequency signals due to the increased plate load resistance of the 6AU6. As far as a picture is concerned, this defect would appear as a severe loss of high frequency definition (Fig. 2), together with faint 120 c.p.s. "hum bars" superimposed on the scene.

**$C_{170}$  changed to .01  $\mu$ f.:** A partially open coupling condenser does not affect the 10 kc., 100 kc. or 500 kc. square-wave signals, but the tilt and concavity of the 50 c.p.s. signal increased as shown in Fig. 6I. Such a defect would affect a picture as shown in Fig. 2, but to a much greater degree. . . It would be completely blurred.

**$C_{170}$  changed to .0001  $\mu$ f.:** When the coupling condenser becomes almost completely open, the 50 c.p.s. square wave is differentiated and appears as a pulse as shown in Fig. 6J, while phase shift even causes the 10 kc. square wave to become tilted as shown in Fig. 6K. Both the 100 kc. and 500 kc. square-wave signals remain unaffected, however. Such a defect would result in severe "smearing" of a reproduced picture.

**$L_{189}$  opened:** An open peaking coil permits its damping resistor ( $R_{139}$ ) to become part of the plate load resistance and to act as a voltage divider with the normal plate load resistor. As may be expected, the only effect of this defect on the 50 c.p.s. and 10 kc. square-wave signals is to reduce their amplitude. The 100 kc. and 500 kc. signals are rounded considerably, however, indicating a severe loss of high frequency components. Such a defect would result in a picture appearing as shown in Fig. 2. The 100 kc. and 500 kc. wave-

<sup>1</sup> Garner, Louis E., Jr.; "Wide Frequency Range Square-Wave" (Hopper, Radio & Television News, March, 1950).

forms are shown in Figs. 6L and 7A, respectively.

**$L_{157}$  shorted:** With peaking coil  $L_{157}$  shorted, the 50 c.p.s. and 10 kc. signals are not affected, and the only effect on the 100 kc. square-wave signal is a slightly increased rounding of the leading edge, while the 500 kc. signal appears as shown in Fig. 7B. On a picture, this defect would result in a slight, but not severe, loss of definition.

**$R_{157}$  shorted:** All square-wave signals are affected with this defect, for peaking coils  $L_{157}$  and  $L_{158}$  act almost alone as a load for the video 2nd detector. Almost all low frequency signals are lost, with a 50 c.p.s. signal appearing as a pulse as shown in Fig. 7C. The 10 kc. signal appears as shown in Fig. 7D, while the 100 kc. signal appears somewhat similar as shown in Fig. 7E. Finally, the 500 kc. signal appears as in Fig. 7F. The effect of this defect on the picture would likewise be severe. Smear would appear, indicative of poor low frequency response and phase shift, and duplicate pictures would appear to follow the image (similar to "ghosts"), indicative of the "ringing" which causes the ripples shown in the higher frequency square-wave signals.

**$R_{158}$  increased to 10,000 ohms:** When the plate load resistor increases in value, low frequency response is generally unaffected, and a 50 c.p.s. square wave appears almost normal as shown in Fig. 7G. High frequency response of the video amplifier suffers, however, and the 100 kc. (Fig. 7H) and 500 kc. (Fig. 7I) are rounded appreciably. Such a defect would result in severe loss of high frequency definition, with the test pattern appearing somewhat as shown in Fig. 2.

**$R_{157}$  changed to 1000 ohms:** In the final example, the plate load resistor for the 6K6 was changed from 3300 to 1000 ohms. It was found that the 50 c.p.s. square-wave signal was affected only as far as amplitude was concerned (somewhat lower in amplitude), but that severe overshoots and "ringing" occurred in all higher frequency square-wave signals. The 10 kc. square-wave signal is shown in Fig. 7J, while the 100 kc. and 500 kc. signals appear as shown in Figs. 7K and 7L, respectively. Such a defect, while not introducing "smear" (as did a short in  $R_{157}$ ), does cause severe "ringing." Multiple images appear right alongside the main image as far as a picture is concerned, with each additional "image" represented by a peak in the oscillatory wavetrain appearing after the leading edges of the square-wave signals shown in Fig. 7 (J to L). It is generally possible to distinguish multiple images due to "ringing" from those due to "ghosts" by several important characteristics.

First, multiple images due to "ringing" only follow sharp changes in picture brightness, such as a change from black to white. On the other hand, "ghosts" are complete duplicate images. Secondly, where ringing occurs, several multiple images are formed, all of which are quite close together,

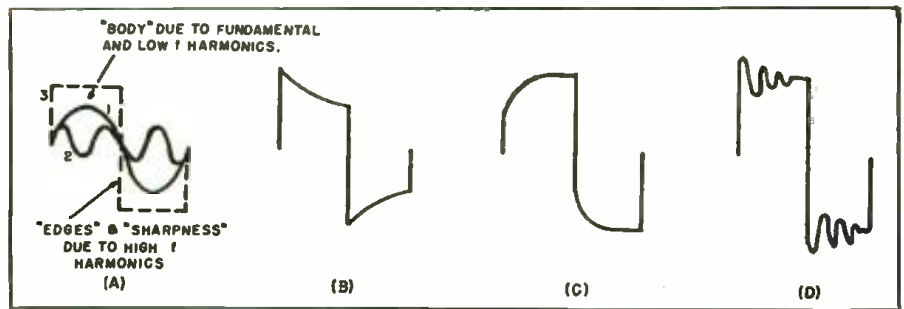

Fig. 5

and with about equal spacing. "Ghosts" may be unequally spaced with respect to one another and the main image, and are usually further apart. In addition, there are seldom more than one or two ghosts present, except in unusual locations.

Finally, the number and appearance of ghosts will generally vary from station to station, while the multiple images due to "ringing" will stay the same on all stations.

#### Scope Not Always Needed

Although we have thus far been concerned primarily with the changes in signal waveform as observed on a cathode-ray oscilloscope, it is often possible to use square-wave signals for testing TV receivers even if an oscilloscope is not available. To do this, two conditions must be met. (1) The cathode-ray tube circuit of the TV receiver must be in operating condition, permitting the video signal represented by the square-wave to appear on the screen of the set; (2) It must be possible to either adjust the frequency of the "hold" controls in the receiver, or the frequency of the square-wave gen-

erator, until the square-wave signal "locks-in" with either the horizontal or vertical sweep circuits.

Assuming that the two conditions outlined above can be met, and this will be true in most cases, then a more rapid servicing technique may be employed. The connections of the square-wave generator remain as in Fig. 4, but no scope is necessary.

A square-wave signal with a frequency between 50 and 70 c.p.s. may be locked-in by adjusting the "Vertical Hold" control, and should appear as shown in Fig. 9A. Each "half" of the screen should be perfectly "white" or "black," with no shades of gray present, as long as the low frequency response of the receiver is normal (it may be necessary to adjust the "Contrast" and "Brightness" controls). A high-frequency square-wave signal (between 150 kc. and 450 kc.), when locked-in by adjustment of the "Horizontal Hold" control, should appear as a series of vertical black and white lines or bars, as shown in Fig. 9B.

Either the upper or lower "half" of the screen may be "white" when a low frequency square-wave signal is used,

Fig. 6

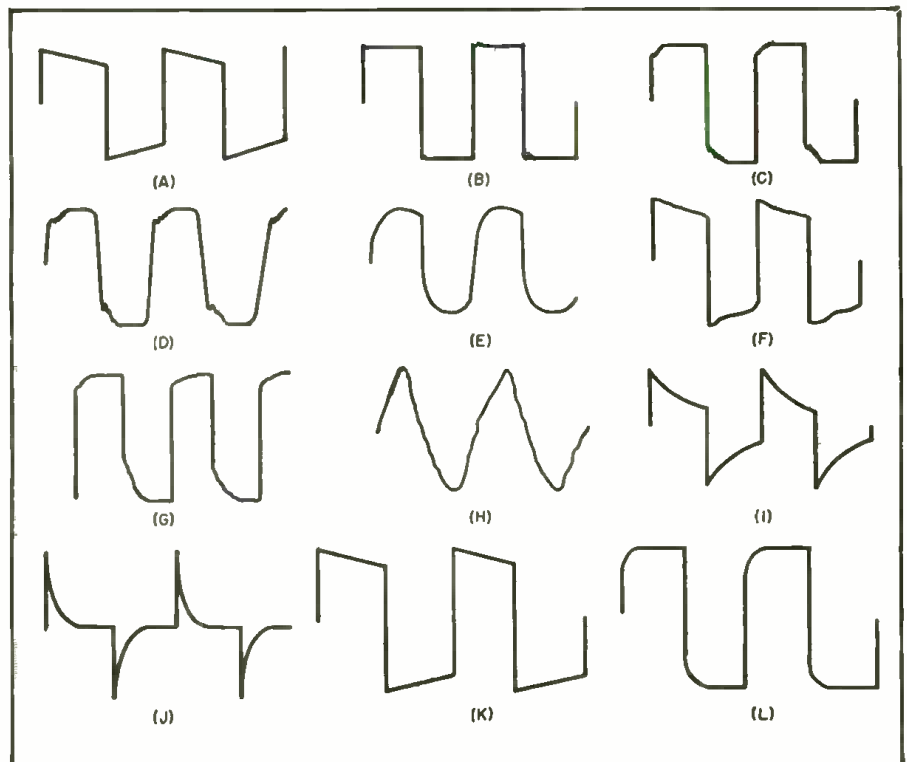

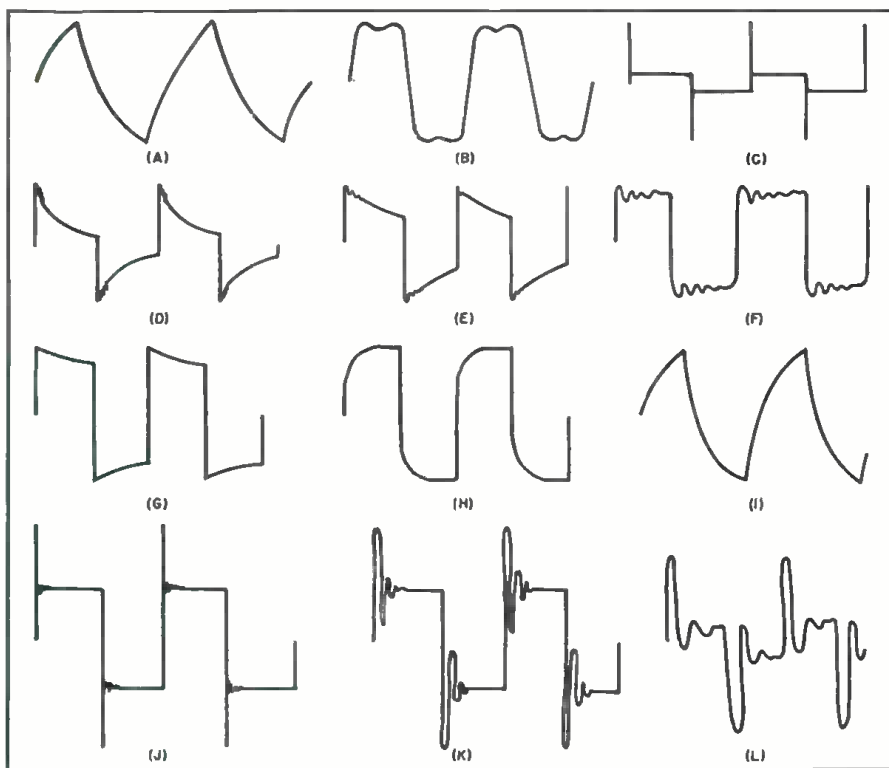

Fig. 7



Fig. 8

depending on exactly how the vertical sweep locks-in with the square-wave signal.

**High Frequency Response** may be determined by examining the vertical bars obtained with a high frequency square-wave signal (Fig. 9B). These bars should be distinct, with sharp black and white edges, and with each bar perfectly white or black.

Poor high frequency response causes a "haziness" along the edges so that the transition from "white" to "black"

is not distinct or clear. This may be caused by too large a plate load resistor in the video amplifier, or by an open or shorted peaking coil, as we have seen (Figs. 6F-G-H-L and 7A-G-H-I).

Phase shift at high frequencies prevents the bars from being perfectly white or black over their entire width, and there may be a fading into gray.

Ring, or damped oscillation, caused by too small a plate load resistor and similar defects (Figs. 7C-D-E-F-J-K-L), results in a series of fine lines following each change from white to black (and vice versa), as shown in Fig. 9C.

**Low Frequency Response** may be similarly checked by observing the pattern on the screen of the TV receiver. With normal response, a 50 to 70 c.p.s. square wave appears as a

Fig. 9

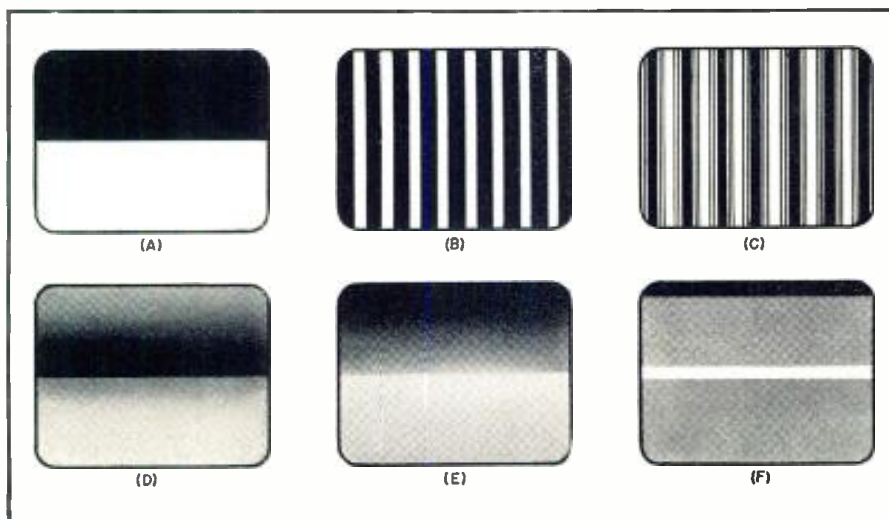

"black" and "white" half, as we have seen in Fig. 9A.

A boost in low frequencies due to over-compensation (Fig. 6E) results in a pattern as shown in Fig. 9D. Instead of sharp and distinct whites and blacks, the pattern appears as gray darkening to black, followed by gray lightening to white.

A loss in low frequencies (Fig. 6I) results in a pattern of black fading to gray, followed by white fading to gray as seen in Fig. 9E.

A severe loss of low frequencies, as may be caused by an open coupling condenser (Fig. 6J-K) appears as a black bar followed by a large gray area, with a white bar followed by a similar large gray area (Fig. 9F).

### Further Applications

If a signal generator supplying signals at either the TV i.f. or r.f. values is available, and it permits external modulation, then the square-wave generator may be used to check over-all response characteristics using the technique just described. The connections shown in Fig. 8 are used.

Be sure that the r.f. signal generator used will permit high-frequency square-wave modulation, however. If the generator does not permit this type of modulation, misleading results may be obtained.

Since a square-wave signal with a frequency between 150 kc. and 450 kc. will produce a number of equally spaced vertical bars or lines on the screen of the picture tube (once locked-in with the horizontal sweep), such a signal may be used for checking the horizontal linearity of the TV receiver, and for adjusting such controls as "Horizontal Drive," "Horizontal Linearity," and "Width."

A square-wave signal with a frequency between 600 and 900 c.p.s. may be locked-in by using the "Vertical Hold" control to produce a number of equally spaced horizontal lines or bars. Such a signal may then be used for checking vertical sweep linearity, and for adjusting the "Vertical Linearity" and "Height" controls.

As we have seen, the square-wave generator, when used alone, or in combination with an oscilloscope or r.f. signal generator, may be used for quickly checking such TV receiver characteristics as *definition, high-frequency response, ringing, low-frequency response and phase-shift, horizontal linearity and vertical linearity*. With these many possible applications, the square-wave generator ranks alongside the cathode-ray oscilloscope in versatility of application.

With a definite need growing for new and more rapid TV receiver servicing techniques, and with TV stations devoting less time to test pattern transmission (requiring other means for checking *definition and sweep linearity*), it may be that the square-wave generator will one day become as important a part of the TV servicing laboratory as is the vacuum tube voltmeter today.

TOM JACOBS, Owner  
Apex Radio Shop  
Detroit, Michigan



***“200% MORE TV BUSINESS  
--NO INCREASE IN OVERHEAD!”***



“With no increase in trained personnel, we tripled our TV service business in 6 months. The answer lies in our G-E Test Equipment. “The *Scope* is the best trouble-shooter on the market . . . it holds a steady trace—it’s stable—you can overload it and it recovers instantly. The *Variable Permeability Sweep* is extremely simple to operate, and with the crystal-controlled

*Marker Generator* we always get accurate and reliable results. While keeping profits up, the G-E Test Package has cut our service time in half!”  
Hundreds of TV dealers and servicemen use G-E Test Equipment to turn out clean, accurate jobs that keep customers satisfied and put money in the till. Call your G-E distributor or mail coupon today for full information.



General Electric Company, Section 951  
Electronics Park, Syracuse, New York  
Rush me latest bulletins plus price information on  
General Electric test equipment.

NAME.....  
ADDRESS.....  
CITY.....STATE.....

*You can put your confidence in—*

**GENERAL  ELECTRIC**



## Heathkit MODEL 0-6 . . . PUSH-PULL . . . 5" OSCILLOSCOPE KIT

The new Heathkit 5" Push-Pull Oscilloscope Kit is again the best buy. No other kit offers half the features — check them.

Measure either AC or DC on this new scope—the first oscilloscope under \$100.00 with a DC amplifier.

The vertical amplifier has frequency compensated step attenuator input into a cathode follower stage. The gain control is of the non frequency discriminating type—accurate response at any setting. A push-pull pentode stage feeds the CR tube. New type positioning control has wide range for observing any portion of the trace.

The horizontal amplifiers are direct coupled to the CR tube and may be used as either AC or DC amplifiers. Separate binding posts are provided for AC or DC.

The multivibrator type sweep generator has new frequency compensation for the wide range it covers: 15 cycles to over 100,000 cycles.

The new model 0-6 scope uses 10 tubes in all, including 5" CR tube. Has improved amplifiers for better response useful to 2 megacycles. Tremendous sensitivity .04V RMS per inch horizontal—.09V RMS per inch vertical. Only Heathkit Scopes have all the features.

New husky heavy duty power transformer has 50% more laminations. It runs cool and has the lowest possible magnetic field. A complete electrostatic shield covers primary and other necessary windings and has lead brought out for proper grounding.

The new filter condenser has separate sections for the vertical and horizontal screen grids and prevents interaction between them. An improved intensity circuit provides almost double previous brilliance and better intensity modulation.

A new synchronization circuit allows the trace to be synchronized with either the positive or negative pulse, an important feature in observing the complex pulses encountered in television servicing.

The magnetic alloy shield supplied for the CR tube is of new design and uses a special metal developed by Allegheny Ludlum for such applications.

The kit is complete, all tubes, cabinet, transformer, controls, grid screen, tube shield, etc. The instruction manual has complete step-by-step assembly and pictorials of every section. Compare it with all others and you will buy a Heathkit.

Model 0-6.....Shipping Wt. 24 lbs.

# \$3950

## NEW INEXPENSIVE Heathkit ELECTRONIC SWITCH KIT

The companion piece to a scope — Feed two different signals into the switch, connect its output to a scope, and you can observe both signals — each as an individual trace. Gain of each input is easily set (gain A and gain B controls), the switching frequency is simple to adjust (coarse and fine frequency controls) and the traces can be superimposed for comparison or separated for individual study (position control).

Use the switch to see distortion, phase shift, clipping due to improper bias, both the input and output traces of an amplifier, — as a square wave generator over limited range.

The kit is complete: all tubes, switches, cabinet, power transformer and all other parts, plus a clear detailed construction manual.



Model S-2  
Shipping Wt. 11 lbs.

# \$1950

## New MODEL V-4 A

## Heathkit VTVM KIT

The new Heathkit Model V-4A VTVM Kit measures up to 30,000 Volts DC and 250 megacycles when used with accessory probes — think of it, all in one electronic instrument more useful than ever before. The AC Voltmeter is so flat and extended in its response ( $\pm 1$  db from 20 cycles to 2 megacycles) that it eliminates the need for separate expensive AC VTVM's.

The new 200 microampere,  $4\frac{1}{2}$ " streamline meter with quality Simpson movement (five times as sensitive as the commonly used 1 MA meter) has a shatter proof plastic meter face for maximum protection. Meter has all the desirable scales and indicates AC volts, DC volts, ohms, db (direct reading), and even has a special zero center marking for quick FM alignment.

There are six complete ranges for each function. Four functions give total of 24 ranges. The 3 volt range allows 33 $\frac{1}{3}$ % of the scale for reading 1 volt, as against only 20% of the scale on the 5 volt types.

New  $\frac{1}{2}$ % ceramic precision resistors are the most accurate commercial type available — you find the same make and quality in the finest laboratory equipment selling for thousands of dollars. The entire voltage divider decade uses these  $\frac{1}{2}$ % resistors.

Both AC and DC voltmeter measurements use a push-pull electronic voltmeter circuit, and the meter circuit makes the meter burn-out proof. Electronic ohmmeter circuit measures resistance over the amazing range of 1/10 ohm to one billion ohms, all with internal 3 volt battery. Ohmmeter batteries mount on the chassis in snap-in mounting for easy replacement.

Voltage ranges are full scale — 3 Volts, 10 Volts, 30 Volts, 100 Volts, 300 Volts, 1000 Volts. Complete decoding coverage without gaps.

The DC probe is isolated for dynamic measurements. Negligible circuit loading. Gets the accurate reading without disturbing the operation of the equipment under test. Kit comes complete: cabinet, transformer, Simpson meter, test leads, complete assembly and instruction manual.



Model V-4A.....Shipping Wt. 8 lbs.

Note New Low Price

# \$2350



## Heathkit 30,000V DC PROBE KIT

A new 30,000 V DC Probe Kit to handle high voltages with safety. For TV service work and all other high voltage applications. Sleek looking — Two color molded plastic — Red body and guard — jet black handle. Comes with connector, cable, and PL55 type plug. Plugs into Heathkit VTVM so that 300V scale is conveniently multiplied by 100. Can be used with any standard 11 megohm VTVM.

No. 336 High Voltage Probe Kit.....Shipping Wt. 2 lbs.

# \$550

## Heathkit RF PROBE KIT

This RF Probe Kit comes complete with probe housing, crystal diode detector, connector, lead and plug and all other parts plus clear assembly instructions. Extends range of Heathkit VTVM to 250 Mc.  $\pm 10\%$ . Works on any 11 megohm input VTVM. Specify No. 309 RF Probe Kit.



Shipping Wt. 1 lb.

# \$550

EXPORT SCHEM  
ROCKE INTERNATIONAL CORP.  
13 E. 40th ST.  
NEW YORK CITY (16)  
CABLE: ARKAD-N.Y.

# The HEATH COMPANY

. . . BENTON HARBOR 15, MICHIGAN



NEW  
**Heathkit TV ALIGNMENT GENERATOR KIT**

Here is an excellent TV Alignment Generator designed to do TV service work quickly, easily, and properly. The model TS-2 when used in conjunction with an oscilloscope provides a means of correctly aligning television receivers.

The instrument provides a frequency modulated signal covering, in two bands, the range of 10 to 90 Mc. and 150 to 230 Mc.—thus, ALL ALLOCATED TV CHANNELS AS WELL AS IF FREQUENCIES ARE COVERED.

An absorption type frequency marker covers from 20 to 75 Mc. in two ranges—therefore, you have a simple, convenient means of frequency checking of IF's, independent of oscillator calibration.

Sweep width is controlled from the front panel and covers a sweep deviation of 0-12 Mc.—all the sweep you could possibly need or want.

And still other excellent features are: Horizontal sweep voltage available at the front panel (and controlled with a phasing control)—both step and continuously variable attenuation for setting the output signal to the desired level—a convenient instrument stand-by position—vernier drive of both oscillator and marker tuning condensers—and blanking for establishing a single trace with base reference level. Make your work easier, save time, and repair with confidence—order your Heathkit TV Alignment Generator now!

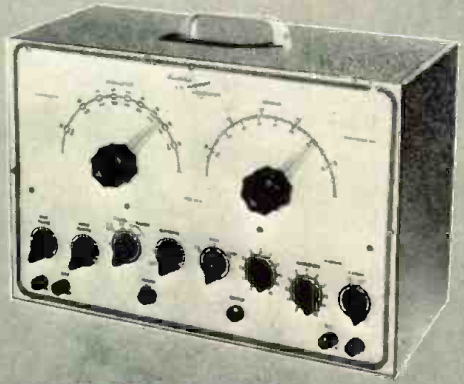

**\$3950**

Model TS-2  
Shipping Wt. ....20 lbs.

**Heathkit SIGNAL GENERATOR KIT**



Model SG-6  
Shipping Wt.  
7 lbs.

**\$1950**

The new Heathkit Signal Generator Kit has dozens of improvements. Covers the extended range of 160 Kc to 50 megacycles on fundamentals and up to 150 megacycles on useful calibrated harmonics; makes this Heathkit ideal as a marker oscillator for TV. Output level can be conveniently set by means of both step attenuator and continuously variable output controls. Instrument has new miniature HF tubes to easily handle the high frequencies covered.

Uses 6CA master oscillator and 6CA sine wave audio oscillator. The kit is transformer operated and a husky selenium rectifier is used in the power supply. All coils are precision wound and checked for calibration making only one adjustment necessary for all bands.

New sine wave audio oscillator provides internal modulation and is also available for external audio testing. Switch provided allows the oscillator to be modulated by an external audio oscillator for fidelity testing of receivers. Comes complete, all tubes, cabinet, test leads, every part. The instruction manual has step-by-step instructions and pictorials. It's easy and fun to build a Heathkit Model SG-6 Signal Generator.

**Heathkit SIGNAL TRACER**

**and UNIVERSAL TEST SPEAKER KIT**

The popular Heathkit Signal Tracer has now been combined with a universal test speaker at no increase in price. The same high quality tracer follows signal from antenna to speaker—locates intermittents—finds defective parts quicker—saves valuable service time—gives greater income per service hour. Works equally well on broadcast, FM, or TV receivers. The test speaker has an assortment of switching ranges to match either push-pull or single output impedances. Also tests microphones, pickups and PA systems. Comes complete—cabinet, 110V 60 cycle power transformer, tubes, test probe, all necessary parts, and detailed instructions for assembly and use.



Model T-2  
Shipping Wt. ....7 lbs.

**\$1950**

**Heathkit TUBE CHECKER KIT**

Test your tubes the modern way—dynamically—the simplest, yet fastest and surest method—your Heathkit has a switch for each tube element and measures that element—no chance for open or shorted elements slipping by. All the advantages of the mutual conductance type without the slow cumbersome time consuming setups. Checks for opens, shorts, each element individually, filament and filament tap continuity, and emission.

This Tube Checker has all the features—beautiful 3 color BAD-? GOOD meter—complete selection of voltages—roller chart listing hundreds of tubes including the new 9 pin miniatures—finest quality Centralab lever switches—high grade birch, counter-type cabinet—continuously variable line adjust control—every feature you need to sell tubes properly. The most modern type tube checker with complete protection against over-see. Uses only the best of parts—rugged oversize 110V 60 cycle power transformer, finest of Mallory and Centralab switches and controls, complete set of sockets for all type tubes with blank spare for future types. Fast action, gear driven roller chart quickly locates the setting for any type tube. Simplified switching cuts necessary testing time to a minimum and saves valuable service time. Simple method allows instant setup of new tube types without waiting for factory data. No matter what the arrangement of tube elements is, the Heathkit flexible switching method easily handles it. Order your Heathkit Tube Checker Kit today and see for yourself that Heath again saves you two-thirds and yet retains all the quality. Complete with instructions, all parts, and cabinet.

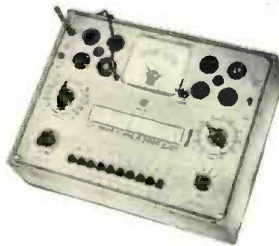

Model TC-1  
Shipping Wt.  
12 lbs.

**\$2950**

**Heathkit CONDENSER CHECKER KIT**



**\$1950**

Checks all types of condensers—paper, mica, ceramic, electrolytic. All condenser scales are direct reading and require no charts or multipliers. Covers range of .00001 MFD to 1000 MFD. A Condenser Checker that anyone can read. A leakage test and polarizing voltage for 20 to 500 V provided. Measures power factor of electrolytics between 0% and 50% and reads resistance from 100 ohms to 5 megohms. The magic eye indicator makes testing easy.

The kit is 110V 60 cycle transformer operated and comes complete with rectifier tube, magic eye tube, cabinet, calibrated panel and all other parts. Has clear detailed instructions for assembly and use.

Model C-2 ..... Shipping Wt. 6 lbs.

NEW **Heathkit HANDITESTER KIT**

A precision portable volt-ohm-milliammeter. Uses only high quality parts—All precision 1/2% resistors, three deck switch for trouble-free mounting of parts, specially designed battery mounting bracket, smooth acting ohm adjust control, beautiful molded bakelite case, 400 microamp meter movement, etc.

DC and AC voltage ranges 10-30-300-1000-5000V. Ohms range 0-3000 and 0-300,000 Range Milliampers 0-10 Ma, 0-100 Ma. Easily assembled from complete instructions and pictorial diagrams.



**\$1350**

Model M-1 ..... Shipping Wt. 3 lbs.

EXPORT AGENTS  
**ROCKE INTERNATIONAL CORP.**  
131 E. 40th ST.  
NEW YORK CITY (16)  
CABLE: ARLAB-N.Y.

**The HEATH COMPANY**

... BENTON HARBOR 15, MICHIGAN

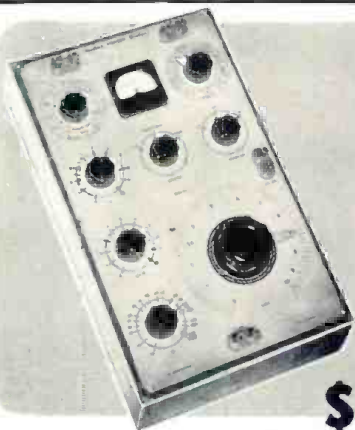

## NEW *Heathkit* IMPEDANCE BRIDGE KIT

This Impedance Bridge Kit is really a favorite with schools, industrial laboratories, and serious experimenters. An invaluable instrument for those doing electrical measurements work. Reads resistance from .01 Ohms to 10 megohms, capacitance from .00001 MFD to 100 MFD, inductance from 10 microhenries to 100 henries, dissipation factor from .002 to 1, and storage factor from 1 to 1000. And you don't have to worry about selecting the proper bridge circuit for the various measurements — the instrument automatically makes the correct circuit when you set up for taking the measurement you want. Bridge utilizes Wheatstone, Hay, Maxwell, and capacitance comparison circuits for the wide range and types of measurements possible. And it's self powered — has internal battery and General Radio 1000 cycle hummer. No external generator required — has provisions for external generator if measurements at other than 1000 cycles are desired.

Kit utilizes only highest quality parts. General Radio main calibrated control. General Radio hummer, Mallory ceramic switches, excellent 200 microamp zero center galvanometer, laboratory type binding posts with standard 3/4 inch centers, 1/2% precision ceramic-body type multiplier resistors, beautiful birch cabinet and ready calibrated panel. (Headphones not included.)

# \$6950

Model IB-1B...Shipping Wt. 15 lbs.

Take the guesswork out of electrical measurements — order your Heathkit Impedance Bridge Kit today — you'll like it.

### *Heathkit* LABORATORY RESISTANCE DECADE KIT



Model RD-1

An indispensable piece of laboratory equipment — the Heathkit Resistance Decade Kit gives you resistance settings from 1 to 99,999 ohms IN ONE OHM STEPS. For greatest accuracy, 1/2% precision ceramic-body type resistors and highest quality ceramic wafer switches are used.

Designed to match the impedance bridge above, the Resistance Decade Kit has a beautiful birch cabinet and attractive panel. It's easy to build, and comes complete with all parts and construction manual.

Ship. Wt.  
4 lbs.

# \$1950

### *Heathkit* LABORATORY POWER SUPPLY KIT

Every experimenter needs a good power supply for electronic setups of all kinds. This unit has been expressly designed to act as a HV supply and a 6.3 V filament voltage source.

Voltage control allows selection of HV output desired (continuously variable within limits outlined), and a Volts — Ma switch provides choice of output metering. A large, plainly marked, and direct reading meter scale indicates either DC voltage output in volts or DC current output in Ma. (Range of meter 0-500V DC, 0-200 Ma DC). Instrument has convenient stand-by position and pilot light.

Comes with power transformer, filament transformer, meter, 5Y3 rectifier, two 1619 control tubes, completely punched and formed chassis, panel, cabinet, detailed construction manual, and all other parts to make the kit complete.



Model PS-1  
Ship. Wt. 20 lbs.

#### LIMITS:

No load.....	Variable	150-400V DC
25 Ma.....	Variable	30-310V DC
50 Ma.....	Variable	25-250V DC
Higher loads.....	Voltage drops off proportionally	

# \$2950

### *Heathkit* BATTERY ELIMINATOR KIT



Model  
BE-2

Ship. Wt.  
19 lbs.

# \$2250

A few auto radio repair jobs will pay for the Heathkit Battery Eliminator Kit. It's fast for service. The voltage can be lowered to find sticky vibrators or raised to ferret out intermittents. Provides variable DC voltage 5 to 7 1/2 Volts at 10 Amps, continuous or 15 Amps, intermittent.

Also serves as storage battery charger. A well filtered, rugged power supply uses heavy duty selenium rectifier, a husky choke, and a 4000 MFD electrolytic condenser for clean DC. 0-15V voltmeter indicates output which is variable in eight steps. Better equipped for all types of service — it means more income.

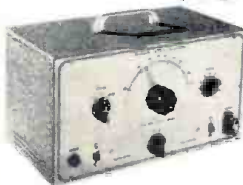

Model AG-7  
Ship. Wt. 15 lbs.

# \$3450

### NEW *Heathkit* SINE and SQUARE WAVE AUDIO GENERATOR KIT

We proudly present the NEW MODEL Sine and Square Wave Audio Generator Kit. Designed with versatility, usefulness, and dependability in mind, the AG-7 gives you the two most needed waveshapes right at your fingertips — the sine wave and the square wave.

The range switch and plainly calibrated frequency scale give rapid and easy frequency selection, and the output control permits setting the output to any desired level.

A high-low impedance switch sets the instrument for either high or low impedance output — on high to connect to high impedance load, and on low to work into a low impedance transformer with negligible DC resistance.

Coverage is from 20 to 20,000 cycles, and distortion is at a minimum — you can readily trust the output waveshape.

6 tubes, quality 4 gang tuning condenser, power transformer, metal cased filter condenser, 1/2% precision resistors in the frequency determining circuit, and all other parts come with the kit — plus, a complete construction manual. A tremendous kit, and the price is truly low.

### TWO HIGH QUALITY *Heathkit* SUPERHETERODYNE RECEIVER KITS



Model BR-1 Broadcast  
Model Kit covers 550  
to 1600 Kc. Shipping  
Wt. 10 lbs.

# \$1950

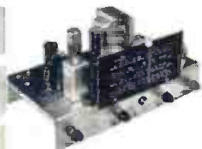

Model AR-1 3 Band  
Receiver Kit covers 550  
Kc. to over 20 Mc.  
continuous. Extremely  
high sensitivity. Shipping  
Wt. 10 lbs.

# \$2350

Two new Heathkits. Ideal for schools, replacement of worn out receivers, amateurs and custom installations.

Both are transformer operated quality units. The best of materials used throughout — six inch calibrated slide rule dial — quality power output transformers — dual iron core shielded I.F. coils — metal cased filter condenser. The chassis has phono input jack, 110 Volt output for phono motor, and there is a phono-radio switch on panel. A large metal panel simplifying installation in used console cabinets is included. Comes complete with tubes and instruction manual incorporating pictorials and step-by-step instructions (less speaker and cabinet). The three band model has simple coil turret which is assembled separately for ease of construction.

### *Heathkit* FM TUNER KIT

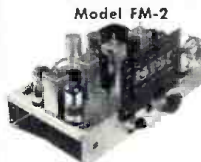

Model FM-2

Ship. Wt. 9 lbs.

# \$2250

The Heathkit FM Tuner Model FM-2 was designed for best tonal reproduction. The circuit incorporates the most desirable FM features — true FM.

Utilizes 8 tubes: 7E5 Oscillator, 6SH7 mixer, two 6SH7 IF amplifiers, 6SH7 limiter, two 7C4 diodes as discriminator, and 6X5 rectifier.

The instrument is transformer operated making it safe for connection to any type receiver or amplifier. Has ready wound and adjusted RF coils, and 2 stages of 10.7 Mc IF (including limiter). A calibrated six inch slide rule dial has vernier drive for easy tuning. All parts and complete construction manual furnished.

EXPORT AGENT  
ROCKE INTERNATIONAL CORP.  
125 E. 40th St.  
NEW YORK CITY (16)  
CABLE: AR1AB-N.Y.

# The HEATH COMPANY

... BENTON HARBOR 15, MICHIGAN

## Heathkit ECONOMY . . . 6 WATT AMPLIFIER KIT



**\$12.50**

Model A-4. Ship. Wt. 8 lbs.

This new Heathkit Amplifier was designed to give quality reproduction and yet remain low in price. Has two preamp stages, phase inverter stage, and push-pull beam power output. Comes complete with six

tubes, quality output transformer (to 3-4 ohm voice coil), husky cased power transformer and all other parts. Has tone and volume controls. Instruction manual has pictorial for easy assembly. Six watts output with response flat  $\pm 1\frac{1}{2}$  db from 50 to 15,000 cycles. A quality amplifier kit at a new low price. Better build one.

No. 304. 12 inch Speaker ..... \$6.95

## Heathkit HIGH FIDELITY . . . 20 WATT AMPLIFIER KIT

Our latest and finest amplifier — the Model A-6 (or A-6A) is capable of a full 20 Watts of high fidelity output — good faithful reproduction made possible through careful circuit design and the use of only highest quality components. Frequency response within  $\pm 1$  db from 20-20,000 cycles. Distortion at 3 db below maximum power output (at 1000 cycles) is only .8%.

The power transformer is rugged and conservatively rated and will deliver full plate and filament supply with ease. The output transformer was selected because of its exceptionally good frequency response and wide range of output impedances (4-8-16-150-600 ohms). Both are Chicago Transformers in drawn steel case for shielding and maximum protection to windings.

The unit has dual tone controls to set the output for the tonal quality desired — treble control attenuates up to 15 db at 10,000 cycles — bass control gives bass boost up to 10 db at 50 cycles.

Tube complement consists of 5U4G rectifier, 6SJ7 voltage amplifier, 6SN7 amplifier and phase splitter, and two 6L6's in push-pull output. Comes complete with all parts and detailed construction manual. (Speaker not included)

MODEL A-6: For tuner and crystal phono inputs. Has two position selector switch for convenient switching to type of input desired. Shipping Wt. 18 lbs. .... \$33.50

MODEL A-6A: Features an added 6SJ7 stage (preamplifier) for operating from variable reluctance cartridge phono pickup, mike input, and either tuner or standard crystal phono pickup. A three position selector switch provides flexible switching. Shipping Wt. 18 lbs. .... \$35.50



**\$33.50**



**\$4.95**

Blonde birch veneer cabinet for either of the receivers or tuner. The modern styling is an asset to any room. 5" speaker fits in end of cabinet when used with receivers (Speaker not included.) Size 7 x 13 $\frac{1}{2}$  x 18 $\frac{1}{4}$  inches. Order No. 345 for either receiver model. Specify No. 350 for the FM Tuner

Shipping Wt. .... 5 lbs.

Metal professional type communications receiver cabinet. Finished in deep grey and fits the panel supplied with Heathkit BR-1 and AR-1 Receivers. 5" speaker mounts in end of cabinet. (Speaker and panel shown not included with cabinet.) Gives professional appearance to Heathkit receivers. Size 7 x 14 x 7 $\frac{3}{4}$  inches.

Specify No. 335. Shipping Wt. 6 lbs.



**\$4.50**



MAIL TO THE  
**HEATH COMPANY**  
BENTON HARBOR 15,  
MICHIGAN

## ORDER BLANK

From \_\_\_\_\_

SHIP VIA

- Parcel Post  
 Express  
 Freight  
 Best Way

Quantity	Item	Price	Quantity	Item	Price
	Heathkit Oscilloscope Kit — Model O-6			Heathkit R.F. Probe Kit — No. 309	
	Heathkit VTVM Kit — Model V-4A			Heathkit H.V. Probe Kit — No. 336	
	Heathkit FM Tuner Kit — FM-2			Heathkit R.F. Signal Gen. Kit — Model SG-6	
	Heathkit Broadcast Receiver Kit — Model BR-1			Heathkit Condenser Checker Kit — Model C-2	
	Heathkit Three Band Receiver Kit — Model AR-1			Heathkit Handitester Kit — Model M-1	
	Heathkit Amplifier Kit — Model A-4			Heathkit Power Supply Kit — Model PS-1	
	Heathkit Amplifier Kit — Model A-6 (or A-6A)			Heathkit Resistance Decade Kit — Model RD-1	
	Heathkit Tube Checker Kit — Model TC-1			Heathkit Impedance Bridge Kit — Model IB-1B	
	Heathkit Audio Generator Kit — Model AG-7				
	Heathkit Battery Eliminator Kit — Model BE-2				
	Heathkit Electronic Switch Kit — Model S-2				
	Heathkit T.V. Alignment Gen. Kit — TS-2				
	Heathkit Signal Tracer Kit — Model T-2				

On Parcel Post Orders, include postage for weight shown and insurance. (We insure all shipments.)

On Express Orders, do not include transportation charges — they will be collected by the Express Agency at time of delivery.

Enclosed find  Check  Money Order for \_\_\_\_\_

Please ship C.O.D.  Postage enclosed for \_\_\_\_\_ lbs.

ALL PRICES SUBJECT TO CHANGE WITHOUT NOTICE

EXPORT AGENT  
ROCKE INTERNATIONAL CORP.  
13 E. 40th ST.  
NEW YORK CITY (10)  
CABLE: 48449-WY

# The HEATH COMPANY

. . . BENTON HARBOR 15, MICHIGAN

# What's New in Radio

For additional information on any of the items described herein, readers are asked to write direct to the manufacturer. By mentioning RADIO & TELEVISION NEWS, the page, and the issue number, delay will be avoided.

## TRIPLETT TUBE TESTER

The Triplett Electrical Instrument Co., Bluffton, Ohio is now in production on a new and improved tube tester, the Model 3413-A.

Designed to permit the checking of



any type radio receiving tube, miniature hearing aid tubes, pilot lamps, flashlight bulbs, and TV picture tubes, the tester gives both "short" and "open" circuit check of each element of every tube. TV picture tubes can be checked without removing them from

the receiver by use of an adapter that may be purchased separately. A continuity test is provided for checking electrical appliances, motors, etc.

The Model 3413-A has flexible 3-position lever switches for complete coverage of present and future tube connections. RTMA pin numbering of the tube element levers makes for quick reference of tube base connections. An illuminated, easy-to-read roll type tube chart is built into the tester.

The instrument is housed in a portable metal case measuring 15 $\frac{1}{2}$ " x 11 $\frac{1}{2}$ " x 6 $\frac{1}{8}$ ".

## SEALED TIMING RELAY

G-V Controls Inc., 28 Hollywood Plaza, East Orange, New Jersey has developed a hermetically sealed thermal time delay relay which has been designed to permit the adjustment of the time interval by the user while the relay remains completely sealed, thus retaining all the advantages of the present non-adjustable sealed thermal timing relays.

Adjustment is made simply by turn-

ing a screw located outside the sealed space. This screw permits the timing to be changed over a 5 to 1 range.

This adjustable relay is made in a new miniature size approximately  $\frac{1}{4}$  the size of the smallest previously marketed sealed thermal relay. The mini-



ature size,  $\frac{3}{8}$ " in diameter and 2 $\frac{3}{4}$ " seated height, fits a 7-pin miniature tube socket. The unit is also available in the conventional size with octal base. Contacts are single pole, rated at 6 amperes and can be supplied either to close or to open at the end of the timing interval. Relays are available for any energizing voltage up to 125 v. and operate interchangeably on a.c. and d.c. Operating power is 4 watts and relays may be energized continuously without injury.

## "UNIVERTER"

Boonton Radio Corporation of Boonton, New Jersey has announced the

## Manufacturers • Distributors • Radio Service Companies

Standard Manufacturer  
Bulk Pack  
New In Date  
GUARANTEED



# RADIO and TV TUBES!

### ● AVAILABLE FOR IMMEDIATE DELIVERY ●

1B3GT	5V4	6AV6	6C4	6S4	6W4	12BA6	50L6GT
1R5	6AH6	6BA6	6CB6	6SL7GT	12AU7	12BE6	211
1U4	6AL5	6BC5	6H6	6SN7GT	12AT6	12SQ7GT	807
1X2A	6AQ5	6BE6	6J6	6SQ7M	12AT7	35C5	813
3S4	6AT6	6BG6	6J7GT	6T8	12AV6	35W4	VR150
5U4G	6AU6	6BQ6GT	6N7	6V6GT	12AV7		

Most of the above tubes available from 50% to 60% off list prices. Minimum quantities—50 of each type.

### ● MANY OTHER TYPES AVAILABLE ●

WE BUY, TRADE or SELL Magnet Wire, Resistors, Condensers, Radio, TV and Special Purpose Tubes. Send us your Requirements or a Description of What You Have for Sale.

QUANTITY BUYERS—Write, Wire or Call for Special Quotations

SUBJECT TO PRIOR SALE

## ELECTRONIC EXPEDITERS

NOTE OUR NEW ADDRESS—

225 North Wabash Avenue  
ANDOVER 3-0843 • CHICAGO 1, ILLINOIS



Music's immortals play again, sing again, in RCA Victor's "Treasury of Immortal Performances"

## *A treasury of Music's Immortals*

Now artists whose names are musical legend live again for the modern listener. You can hear them, at their finest, in RCA Victor's "Treasury of Immortal Performances."

In recreating these performances on both 33 and 45 rpm, acoustical engineers drew on a vault of master records guarded for posterity by RCA Victor. But new electronic techniques, developed through RCA research, give the new records a quality far surpassing that of the originals.

Because RCA Victor could draw on so vast a storehouse of the past, there is something in the "Treasury of Immortal Performances" for listeners of every age and taste. Caruso sings light and serious music—as do Schumann-Heink, Mary Garden, and others . . . Paderewski is here . . . and, if your taste is for popular music, such greats as Berigan, Armstrong, Waller, in rare early records.

\* \* \*

See the latest wonders of radio, television, and electronics at RCA Exhibition Hall, 36 West 49th St., N. Y. Admission is free. Radio Corporation of America, RCA Building, Radio City, N. Y. 20, N. Y.



The magic of RCA Victor's "45" system—as an independent unit, or combined with radio or television receivers—has already led 55 record-makers to adopt it.



**RADIO CORPORATION of AMERICA**

*World Leader in Radio — First in Television*

# SAVE UP TO 95% SENSATIONAL SURPLUS VALUES!

## EXPORT INQUIRIES INVITED!

We carry an unusually large stock of Airline Equipment, Test Equipment, Radar Sets, etc. Write for our low prices and complete information. We furnish immediate answers to all inquiries! Write today

### ATTN: AIRLINE OPERATORS

APN-9 with MG-149F or PE-206  
DY-17  
TA-2124  
SCR-522A, AM or C  
SCR-718C  
BC-316  
AM ARN-8  
AFS-4  
AFS-6  
SCR-717  
TBS-3, 4 or 5  
HS-33  
TS-226A  
HE-56A  
ARC-4  
SCR-274 N

ARC-5 VHF Set  
TS-19  
BC-611  
O-17 ART-13 LFO Unit  
O-16 ART-13 LFO Unit  
SCR-509  
PP-39/TRC-2  
AT-49/APR-4  
SQ-7 Parts  
RC-73A  
RC-13A Radar  
CP-11/APS-15  
R-5A/ARN-7  
MT-283/ART-13  
MT-284/ART-13  
BC-348 L New  
SCR-723 New  
Plus many others

MODULATION TRANSFORMER, 50 watts, matches 807's to 2000 ohm RF load. Brand new. \$3.49  
CD-307 EARPHONE EXTENSION CORDS, Used with HS-33 and HS-23 Head Sets. Used \$1.59  
BC-434A RADIO COMPASS CONTRL BOX, Complete with 5 Mil. meter. New \$2.95

### PORTABLE LITEWEIGHT HAND MIKE

A beauty! Cups easily into the hand. Made by MAGNA-VOX. Type RS-38. Single Button Carbon with standard PL-68 plug and cord. Like new \$1.95

VACUUM CONDENSERS, 50 MMFD 5 amps, 5 KV Quantities Available \$1.25

### PORTABLE F.M. XMITTERS & RCVR'S!

These operate on 6V DC, 34 MC various either direction depending xtals, xmttr and Rcvr has aluminum case with antenna relay. Xmttr uses 1073.125 KC extra in osc. stage followed by 4 doubles and 1 fin. amp, all using HY 65 tubes. Mike amp. and Fre. Mod. use 1C7G tubes. Xmttr stages have metering jacks. Rcvr is superhet. Xtal cont. local osc at 8060 KC. Power Supply on chassis using Carter 6V gen. output 450 V 250 ma 6V vibrator power supply for receiver. All tubes inst. heating. Included is control box, French Phone Hand Set, 8" speaker and extra microphone. Used, complete set priced at only \$45.00

GO-9 XMITTER. With spare parts kit. Frequency range 3-18 MC and 300-600 KC. Band switching 109 w output. Brand new in original mfg. crates. Comes with tubes and spare parts kit. Comes in three units: high and low frequency xmttr and rectifier. Dimensions: 14" deep x 27" long x 29 1/2" high. Net wt. 137 lbs. Shpg. wt. approx. 250 lbs. Finished in black crackle, shock mounted. Has 7 meters for indicating plate and grid current, also antenna current. Operates 110V 800 cycles. Single phase and 24V DC. Contains 2-803 tubes. 1-807, 1-801, 2-837, 1-523, 2-1616. Comes with maintenance manual and test data. \$72.50

EXPORT QUANTITIES AVAILABLE. Write for complete information.  
SURPLUS RADIO CONVERSION MANUAL NO. 2 containing conversion information for GO-9 to 10 meters and 110V 60 cycles. Contains 18 other popular conversions and complete information. \$2.50

### 274-N & ARC-5 EQUIPMENT

#### RECEIVERS

TESTED BEFORE SHIP  
PING. Guaranteed working!  
3.6 MC. Used. Originally \$50. NOW \$6.95  
6-9.1 MC. Used. \$8.95

T-22 ARC-5, 7-9 Megs  
Used xmt. \$14.95

T-23 ARC-5 100-156 Megs 4 channel Xtal. used. Complete with tubes. Internally Perfect \$39.50  
MDZ-ARC5 Modulator Plate and Screen for T23ARC5, with Dynamotor \$15.00

T-21 ARC-5 3-7 MC. New. Orig. \$40. Now \$19.95  
4-5.3 MC. Used. Orig. \$30.00. Now \$9.95  
2-1.3 MC LN. Orig. \$40. Now \$16.95  
T-19 ARC-5, 3 to 4 Megs \$19.95

R-23 ARC-5, 190 to 550 KC, Loop or Straight wire antenna input \$18.95

R-28 ARC-5 VHF Rcvr. XLT Cond \$40.00



#### BC-924 FM XMITTER.

Frequency range 27-39 MC. 35 Watts output. 4-channels, tunable throughout entire range. Complete with tubes and dynamotor. \$19.95

TBY VIBROPACK for TBY Transceiver. Supplies all voltages. Operates on 4 volt source. Brand new. \$12.50

#### IMPORTANT

NO ORDER LESS THAN \$5.00. Send 30¢ deposit on each of items or full amount to save C.O.D. charges. Do not send shipping costs. It will be C.O.D. only. Shipments sent via Rail-way Express unless other instructions given. Merchandise subject to prior sale. Prices subject to change at any time.

## SPECIALS FOR MAY ONLY!

### JUST RECEIVED! ADDITIONAL ASB-7 EQUIPMENT

• ASB-7 INDICATOR. Makes a beautiful Scope Foundation Kit. Has 5BPL, 4-6AC7, 3-6H6. Can also be used for remote TV indicator with conversion. Good condition. Orig. \$30 \$10.75  
• ASB-7 RECEIVER. Contains 446 Lighthouse tube amplifier, 955 local oscillator, 955 mixer, 5 stages of I.F. amp, using 5-6AC7 tubes. Uses 2-6AC7 Video Amp, 1-6H6 detector and 1-6J5 tube. Used, good shape. Complete with tubes \$17.50  
• ASB-7 TRANSMITTER. Contains 2-15E Osc. Tubes, 1-15R Rectifier Tube. Also has blower, relay and post transformer. Complete with coax tuning lines \$6.95  
• ASB-7 POWER SUPPLY. Supplies 2 1/2 V, 5V, 6V, 750V, 2000V, from 800 cycle source. Contains 2x2 rectifier, 5T4 Rectifier Tube, Filter Condensers and 1-6AC7 Tube. Complete with tubes. Xmt shape \$6.95

### BC-1072 RADAR TRANSMITTER

Frequency range 157 to 187 mc/cycles. Comes complete with all tubes, 1 1/2 amp GR Variac. Operates on 110V AC 60 cycles and contains 3 1/2" meter to measure up to 5 KV. \$18.95



### TRIPLETT 1183-SC COMBINATION TUBE & MULTI-TESTER

Checks tubes, AF output, measures AC, DC volts, direct current, resistance, cap. Can be used as free-point tester for measurements at tube sockets while radio is on, without removing chassis. 0 to 50 / 250 / 500 1000 AC, DC volts. Ohms/volt: 10,000 DC, 2000 A.C. DC MA 0 1 / 10 / 50 250. Ohms: 0-500-15,000-0-1.5 or 15 megs. Used, good cond. Part of 1-56C test set. 1 1/4" x 7 1/4" x 4 1/4". Weighs 5.2 lbs. Only a few left. CLEARANCE PRICED \$39.50

VARIAC, GR. 0-130 volts, AC 60 cycles, 5 amps. 7 1/2 A intermittent. Brand new and specially priced at just \$18.95

GENERAL ELECTRIC VOLT METER 0 to 150 Volts, AC, 60 cycles, 3 1/2" diameter. Brand new. Specially priced at just \$4.95

ARC-4 VHF TRANSCIEVER. 140 to 144 Megs. Comes complete with tubes, dynamotors and crystals \$35.00

### BC-347 INTERPHONE AMPLIFIER.

Contains 6F8 \$2.95  
Dual Triode and matching transformer. Brand new

### BC-611 HANDIE-TALKIE.

Part of SCR-536. Frequency 3.5-6 MC. Attention Construction men, builders, surveyors. Perfect for short distance communication. Weighs only 5 1/2 lbs., hand-held like a hand set. Pre-set to your frequency. Push-button controlled. Transmitter and receiver in same case 1 1/2" x 3 1/2" x 5 1/2" sturdy aluminum case. Comes complete with tubes, crystals, one set batteries. Extra batteries available. Models B, C, D, E, F, available. We supply these sets with newly mfg. batteries, tested in accordance with Tech. Manual. PRICE ON REQUEST.

availability of a new accessory unit for its BRC Type 202-B FM signal generator.

The Type 207-A "Univerter" is designed for use with the company's signal generator to provide frequency coverage from .1 mc. to 55 mc. Since the Type 202-B FM signal generator covers a frequency range from 54 to



216 mc., this combination of instruments permits continuous coverage from .1 mc. to 216 mc.

The "Univerter" is equipped with a frequency increment dial which is calibrated in increments of 5 kc. from plus 300 kc. through zero to minus 300 kc. This permits making selectivity measurements on narrow-band receivers.

The r.f. output voltage across a 53 ohm load connected at the unity gain jack is continuously variable from .1 microvolt to .1 volt by means of the 202-B signal generator attenuator. The gain is constant within ±1 db. over the entire frequency range of the instrument.

Complete details on this new accessory are available from the company on request.

### RESISTANCE COMPARATOR

Of interest to manufacturers is the new high speed automatic resistance comparator being marketed by *Clippard Instrument Laboratory, Inc.* of Bank Street, Cincinnati, Ohio.

The Model PR-5 will enable unskilled labor to test as many as 17 re-



sistors per minute, irrespective of type. The new unit has been specifically designed for checking incoming shipments of resistors, matching, grading to close tolerances, or checking factory output.

### NEW STANDARD BRAND CHOKES

HY	BRAND	MILS	OHMS	PRICE	VOLTAGE	CASE	WT.
8-40	Stancor	175	100	2.75	3KV	Closed	3.5
8-30	Stancor	200	80	3.25	3KV	Closed	4.5
5-25	UTC	200	100	4.95	2KV	Closed	5
5-25	UTC	300	90	9.95	5KV	Closed	18
8-25	Stancor	300	80	5.95	5KV	Open	8 1/2
5-25	Stancor	300	80	4.95	3KV	Open	4
5-25	UTC	500	60	12.95	7KV	Closed	28
8-40	UTC	1 amp	50	39.95	10KV	Closed	58

### SMOOTHING CHOKES

HY	BRAND	MILS	OHMS	PRICE	VOLTAGE	CASE	WT.
5	GTC	500	600	4.95	2KV	Closed	4
7	Stancor	150	200	1.25	2KV	Open	2
10	UTC	500	60	12.95	7KV	Closed	28
12	Stancor	300	80	5.95	5KV	Closed	9
12	Thornderson	375	105	3.95	5KV	Closed	8
12	Thornderson	400	400	6.95	2KV	Closed	15
15	Stancor	200	120	2.95	3KV	Open	4.5 lbs.
20	Stancor	300	80	4.95	3KV	Closed	9 lbs.
20	UTC	300	90	4.50	4KV	Closed	10 lbs.
20	UTC	400	85	5.95	5KV	Closed	14 lbs.

### SAVE 5 ON POWER SUPPLIES

HY	Buy These Chokes with Hum Bucking Tap	BRAND	MILS	OHMS	PRICE	VOLTAGE	CASE	WT.
20 Series	UTC	1A	50	39.50	10K	Closed	80	
5 Parallel	UTC	2A	12.5					
16 Series	UTC	175	96	5.95	2.5K	Closed	15	
4 Parallel	UTC	350	24					
26 Series	UTC	200	112	6.95	3.5K	Closed	15	
6.25 Parallel	UTC	400	28					

## RADIO & ELECTRONICS SUPPLY

DEPT. 21, 2033-37 W. VENICE BLVD. LOS ANGELES 6, CALIFORNIA

### BUILD YOUR OWN GEIGER COUNTER!

It's EASY to build your own Searchmaster Geiger Counter with this COMPLETE kit. Contains everything you need! Headset, tubes, batteries, metal case. Fully guaranteed! Sensitive to both beta and gamma radiation! Illus. instructions. FREE radioactive specimen.



Write for FREE literature

SCIENCE KITS LTD. \$29.95

8049 St. Clair • North Hollywood, Calif.

### WANTED

• PE-237 POWER SUPPLY  
• GN-58 GENERATOR  
• 1306 TRANSMITTER RECEIVER  
BEST PRICES—NO QUANTITY TOO BIG, NONE TOO SMALL.

WRITE TODAY GIVING DETAILS TO — Box 515  
C/O RADIO & TELEVISION NEWS  
366 Madison Ave. New York 17, N. Y.

*new  
cure  
for  
old  
ailments*



ghosts



low signal strength

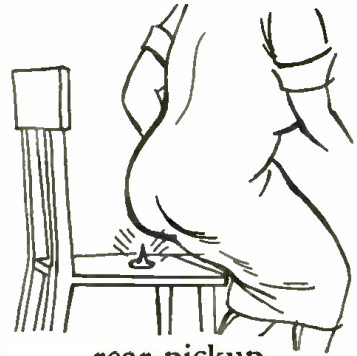

rear pickup

# YAGIS

by CHANNEL MASTER

## NEW "500" SERIES

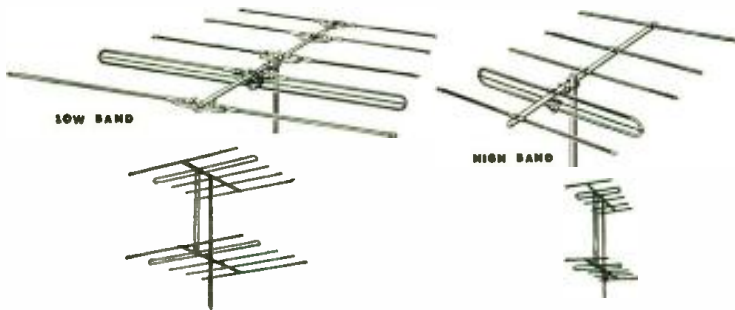

Ch.	No.	List Price
2 3	502 503	<b>\$17.65</b>
4-6	504- 506	<b>16.67</b>
7-13	507- 513	<b>7.65</b>



Completely pre-assembled for instant set-up.

## STRETCH YOUR TV MARKET BEYOND PRESENT LIMITS

Now — say goodbye to reception problems common to fringe and sub-fringe areas. Get "up close" to those distant TV transmitters—*stretch* your market—open up new TV areas with Channel Master's new line of 5 element Yagis.

Precision cut for every channel, the "500" series combines high gain with high directivity at amazing low cost.

- Aluminum elements and crossarm.
- High impedance step-up dipoles of seamless tubing.
- **Actual** gain of single bay, 8 DB (*not* theoretical).
- Front to back ratio, 26 DB.
- Matches 72 or 300 ohm line.
- Reflectors and directors of  $\frac{3}{8}$ " butted tubing,  $\frac{1}{2}$ " external sleeve.
- 1" crossarm on channel 2 and 3,  $\frac{3}{4}$ " crossarm on all other channels.

Sold only through Channel Master distributors.



# CHANNEL MASTER CORP.

NAPANOCH ROAD, ELLENVILLE, N. Y.

LEARN

# Television - Radio OR Electricity

IN THE GREAT SHOPS OF **COYNE**



**TRAIN QUICKLY!**  
**OLDEST, BEST EQUIPPED**  
**SCHOOL of ITS KIND in U.S.**  
*Young and Older Men*

Come to the Great Shops of Coyne in Chicago. Get practical training in TELEVISION-RADIO or ELECTRICITY—vital in Defense Program. Prepare now for a better job or better service rating.

**START NOW—PAY LATER**

You can finance most of your tuition, pay for it later in easy monthly payments. Special plan for men of Draft Age. Part time employment service available.

GI APPROVED

**FREE BOOK** Clip coupon for Big Free Illustrated Book. Indicate below, course that interests you. No salesman will call. Act NOW.

An Institution not for Profit

B. W. COOKE, Pres.  
COYNE Electrical & Television-Radio School.  
500 S. Paulina St., Chicago 12, Ill. Dept. 51-85H  
Send FREE BOOK and full details on:

TELEVISION-RADIO     ELECTRICITY

NAME .....

ADDRESS .....

CITY ..... STATE .....

**COUPON-OF-THE-MONTH**

- TUBES—STD. BRAND 12SQ7..... 2 for 50.99
- OUTPUT TRANSFORMERS (for 50L6)..... 2 for .99
- VOL. CONTROLS—STD. BR. 3 MEG. W. SW..... 2 for .99
- CONDENSERS—40-40 Mfd. 150V..... 2 for .99
- CONDENSERS—40-20 Mfd. 150V FP..... 2 for .99
- LOOP ANTENNA—III GAIN 12"x8"..... 2 for .99
- SAPPHIRE PHONO NEEDLES (list \$2.50)..... 2 for .99
- OSC. COILS 455 KC (for 12SA7)..... 4 for .99
- BY-PASS COND. KIT—18 Ass'd..... .99
- DIAL CORO KIT—100 ft. Ass'd. & 6 Springs..... .99
- GRILLE CLOTH—4 Ass'd. 6"x8" & 10 Knobs..... .99
- COMBINATION KIT—All above items—Only..... 10.00

WITH THIS COUPON, ORDER AT ONCE  
Write for Monthly Coupons and Bulletin

RADIO DISTRIBUTING CO., Pasadena 18, Cal.

The instrument, which measures 18" wide, 12" high, and 12" deep, is completely self-contained and requires no outside attachments other than the standard resistor against which the unknown resistors are to be checked.

The meter is a square d.c. d'Arsonval unit inclined for easiest reading with minimum parallax. The meter scale reads in per-cent and is calibrated in three full scale ranges: -5 to +5%, -25 to +30%, and -50 to +100% deviation from standard. Accuracy is better than  $\pm 1\%$  throughout the entire range of from 100 ohms to 100 megohms.

**ELECTRONIC VOLTMETER**

The Daven Company of 191 Central Avenue, Newark 4, New Jersey has recently developed a new electronic voltmeter, the Type 170.

The new unit covers a frequency range from 10 cycles to 250 kc. with an accuracy of  $\pm 2\%$ . Its high stability circuit, with internal regulated power supply, makes its readings independent of normal power line variations.

It has an input impedance of 500,000 ohms while the cathode follower input



provides an effective input capacity as low as 6  $\mu\text{fd}$ . The multiplier control on the voltmeter provides four additional ranges of 20 db. in addition to

the decibel range meter scale 0-20 db.

All readings are taken on a single, large, illuminated meter scale. The unit may also be used as a wide-range, high-gain amplifier because it is equipped with an output jack and separate volume control.

**VARIABLE RESISTOR**

The Wholesale Division of P. R. Mallory & Co., Inc., P.O. Box 1558,

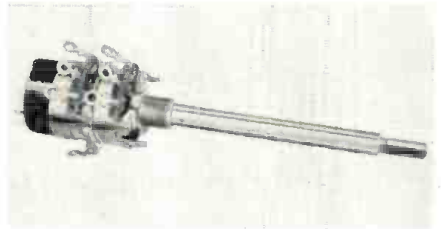

Indianapolis, Indiana has added a new dual concentric 15/16" variable resistor to its line of "Midgetrols."

In order to attain maximum coverage of a great variety of television and auto radio receivers, the dual controls are being sold in subassembly form. The technician can complete the assembly in less than five minutes, combining control sections of specified ratings for his particular application. The control sections are supplied in factory-assembled form, making possible complete factory inspection and testing. A new a.c. switch makes attachment simple and sure by positive indexing and design that permits secure locking in position without removing the control housing.

Additional details are available from the company.

**CIVIL DEFENSE RADIO**

The General Electric Company, Syracuse, New York has developed a special FM radio receiver for use by civil defense organizations having two-way radio systems at their command. The

(Continued on page 124)

*Largest Selling Booster*

**AT ANY PRICE !**



*Regency*



IMMEDIATE DELIVERY OF

*Top Quality*

# MINIATURE SWITCHES

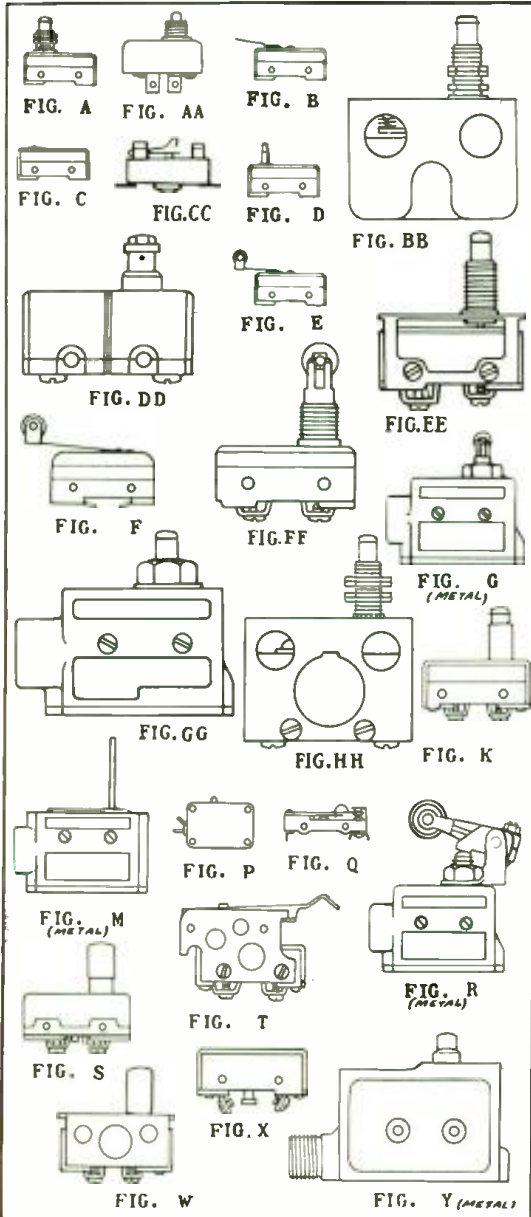

This list of brand new standard brand miniature switches represents only a few of many types in stock at Wells. Large quantities of most types are on hand for your immediate requirements. Write or wire for quotations on switches not listed.

Stock #	Type #	Contact	Fig.	Price	Stock #	Type #	Contact	Fig.	Price
41MC2	2M03.1A	NO	P	50	41MD53	WPSM5	NC	AA	50
41MM2	AC2101BE	SPDT	W	85	41MC27	W22RST	NC	D	55
41MC6	APB236	SPDT	A	1 15	41MD48	W22RT	NC	C	65
41MC26	APG210	NO	A	80	41MD33	W23PW2	NC	F	80
41MC17	B-1	NC	Y	1 45	41MD16	W27R	NC	C	55
41MC16	B-1T	NC	DD	90	41MD43	W27RQ1T	NC	A	70
41MC7	B-14	NO	HH	1 70	41MC15	W27RQ2	NC	A	70
41MD62	B-R	SPDT	C	70	41MD36	W27RST	NC	D	55
41MD46	B-RL18	SPDT	B	95	41MC24	WZE7RQTN	NC	Y	1 45
41MD63	B-RS36	SPDT	D	80	41MC23	WZE7RQTN	NC	R	3 75
41MD23	BD-RL32	SPDT	B	95	41MD54	WZ88X	NC	X	80
41MLH	BZRQ41	SPDT	W	85	41MC9	WZR31	NC	C	65
41MD51	BZ-R37	SPDT	C	70	41MD57	WZR31	NC	T	70
41MD2	BZE7RQ2	SPDT	GG	1 70	41MD31	WZRD	NC	C	55
41MD21	BZ-7RST	SPDT	D	80	41MD19	WZRL8	NC	B	70
41MD38	BZE2RQ9TN1	SPDT	G	2 65	41ML3	WZRQ41	NC	W	65
41MD6	CUM 24155	NO	E	80	41ML2	WZV7RQ9T1	NC	G	2 25
41ML1	D	NO	BB	1 50	41MC21	X757	NC	C	55
41MC12	D in case	NC	Y	1 45	41MD37	XCL1A	NC	C	55
41MD34	ES692070	NC	CC	50	41MC5	XD45L	SPDT	B	95
41MD65	G-R26	NO	C	60	41MD4	Y2	NO	C	75
41MD60	G-RL	NO	B	80	41MD40	YA2RLE4D13	NO	B	70
41MC11	G-RL 5	NO	B	80	41MD24	Y22YLTC1	SPDT	B	95
41MD61	G-RL35	NO	B	80	41MC1	Y22YST	SPDT	D	60
41MD41	G-RL43	NO	B	80	41MD13	Y23R3	NO	C	60
41MD64	G-RS	NO	D	55	41MD56	Y23RLTC2	NO	B	80
41MD66	G-RS36	NO	D	60	41MC14	Y23RW2T	NO	F	90
41MC32	HRO 7.1PZTSP1	NO	K	65	41MD49	Y27RQ9T6	NO	FF	85
41MC19	HRO 7.4P2T	NO	S	60	41MD32	Y27RST	NO	D	60
41MD8	HRRC 7.1A	NC	C	55	41MC13	Y27RA6	NO	EE	1 00
41MD27	HRRD 7.1A	NO	C	60	41MD25	Y2RQ1	NO	A	80
41MC31	LN-11 HD3	SPDT	M	1 70	41MC20	Y2RQ4	NO	S	60
41MC18	MLB 321	SPDT	B	95	41MD59	Y2RQ41	NO	W	75
41MD1	MLR 643	NC	B	70	41MD20	Y27RQT	NO	K	65
41MD55	PS 2000	SPDT	C	85	41MD42	Y2RTX1	NO	X	95
41MC28	RC71P2T	NC	A	70	41MC27	Z	NC	Y	1 45
41MD45	RO1P2T	NO	A	80	41MD44	Blue Stripe	SPDT	C	70
41MD22	RO2M	NO	E	80	41MD52	Blue Dot	SPDT	E	90
41MD28	RO2M12T	NO	E	80	41MC8	Red Dot	NC	C	65
41MC25	R-RS	NC	D	50	41MD18	Open Type	SPDT	Q	50
41MD47	R-RS13	NC	D	90	41MD39	Green Dot	NO	B	80
41MD9	SW-186	NC	D	50	41MC29	Green Dot	NO	D	55
41MC10	WP3M5	NC	AA	50	41MD26	Precision	SPDT	B	95
41MC4	WPSM3	NC	AA	50					

Order Direct or Through Your Local Parts Distributor

PARTS SHOW VISITORS:

Be sure to visit our new Chicago Ave. display. Plenty of free parking.

**Seeley 8-4143**

WIDE SELECTION OF ELECTRONIC COMPONENTS AT  
**WELLS**

- Tubes • Resistors • Condensers • Wire and Cable
- Volume Controls • Co-ax Connectors • Relays • Rectifiers
- Transformers • Chokes • Micro Switches, Toggles • Antennas
- Accessories • Electronic Assemblies • Dial Light Assemblies

**WELLS**  
SALES, INC.

833 W. CHICAGO AVE., DEPT. R-5, CHICAGO 22, ILL.

May, 1951

81

# McGEE'S "SUPER STORE" OPERATION SAVES YOU MONEY!



**5 OZ4 TUBE & 5 VIB. \$9.50**  
**DEAL NO. RN-V5 . . . . .**

Here's a red hot deal for you fellows that do a lot of auto radio service. 5 standard brand name 5OZ4 tubes and 5 of our famous 4-prong serrated can vibrators. This vibrator is of the latest design, for long life. Standard diameter can be bent enough to fit all Chrysler auto sets, also fits Motorola, etc. Our 20th Anniversary, big deal No. RN-V5. You can get 5 OZ4 metal tubes and 5 4-prong vibrators, all for \$9.50. Shipping weight 3 lbs.

MN-8	8 mfd 450 volt	39c
MN-16	16 mfd 450 volt	49c
MN-30	30 mfd 450 volt	59c
MN-20	20 mfd 150 volt	39c
MN-40	40 mfd 150 volt	49c
MN-220	20-20 mfd 150v	49c
MN-55	50-30 mfd 150v	59c
MN-442	40-40-20 mfd 150v	69c

All cond. Guaranteed one year.

**RED HOT SPEAKER VALUES**  
 McGee has a tremendous stock of 100-000 speakers to meet every need. Every speaker is fully guaranteed. Order your speakers now.

4 inch, square	1.0 oz. magnet	\$1.99
5 inch, pincushion	1.47 oz. magnet	1.79
6 inch, pincushion	1.47 oz. magnet	2.79
4 x 6 inch	1.0 oz. magnet	2.29
5 x 7 inch, oval	1.47 oz. magnet	2.49
7 inch, pincushion	2.15 oz. magnet	3.49
8 inch, pincushion	2.15 oz. magnet	3.49
6 x 9 inch, oval	2.15 oz. magnet	3.49

**100 Molded Plastic Bypasses \$9.95**  
 100 molded plastic tubular bypass condensers. All 600 volt and all of the same nationally known mfg. Regular dealers net is over two and one-half times our 20th Anniversary sale price. You'll chuckle when you look these over. Here's what you get: 10-.001, 10-.002, 20-.005, 20-.01, 20-.02, 10-.05 and 10-.1. Our big deal No. RN-V12. 100 plastic tubulars. Shipping weight 2 lbs. Net price, \$9.95.

**100 400 VOLT TUBULARS \$6.95**  
 100 top quality 400 volt tubular by-pass condensers. Made this year by a famous condenser factory. Don't confuse these with grab-bag surplus. McGee's deals are guaranteed to please you. Here's what you get: 10-.001, 10-.002, 20-.005, 20-.01, 10-.02, 20-.05 and 10-.1. 600 volt condensers. Our big deal No. RN-203. Shipping weight 2 lbs. Net price, \$6.95.

**20 50 x 30 150 V. \$10.95 ELECTROLYTICS**  
 Here's a red hot value. 20 of our XX quality replacement electrolytics. The most popular condenser to use today. Takes care of 90% of your AC-DC radio filter needs. Compact construction 1950 production. 1-year guarantee. 30-30 mfd. 150 volt, housed in a cardboard tube with common negative, has long flexible leads. 20th Anniversary, big deal No. RN-204. Sale price, \$10.95.

**SELENIUM RECTIFIERS**  
 65 mil Selenium Rectifier, net .89c each  
 100 mil Selenium Rectifier, net .69c each  
 150 mil Selenium Rectifier, net .79c each  
 200 mil Selenium Rectifier, net \$1.09 each  
 250 mil Selenium Rectifier, net 1.19 each  
 350 mil Selenium Rectifier, net 1.59 each  
 450 mil Selenium Rectifier, net 1.79 each  
 McGee offers you the finest in Selenium rectifiers. All standard 150 volt.

**1 or 4 VOLT CRYSTAL CARTRIDGES \$1.99**  
 McGee offers you a famous make crystal cartridge. Standard size and shape, but very light weight. Will track on 3/4 oz. or more pressure. Stock A-6, one volt output, replaces Astatic L-70 etc., Net \$1.99. Stock No. A-10, 4 volt output, replaces Astatic L-72 and L-82 etc., Net \$1.99. Buy 10 assorted for \$19.95.

**5-Station Intercom Master \$16.95**  
 Model 2700 5-station intercom master, in an attractive walnut cabinet 10x5 1/2 x 10 1/2. Push button for each sub and talk-listen switch and volume control. AC-DC amplifier with lots of power and full size Alnico V PM speaker. 1950 production of a famous factory. Only 300 left, weight 7 lbs. Model 2700, net, \$16.95.

**10-Station Intercom Master \$24.95**  
 Heavy duty Model 12520 10-station intercom master in beautiful walnut cabinet. 14x6 1/2 x 7 1/2 high. Powerful AC amplifier with 6V6 output, 6S7 and 80 rectifier. Heavy 2-1/2 oz. Alnico 3 PM speaker. Push-button for each of 10 stations, talk-listen switch and all call buttons; volume control. Installs as a 3-wire system. A fortunate purchase by McGee makes a saving for you. Model 12520, weight 12 lbs. Net, \$24.95 each.

**19 TUBULAR ELECTROLYTICS DEAL RN-PLI-9 \$1.50**  
 19 tubular electrolytics, guaranteed for one year. All fresh stock in aluminum tubes with cardboard insulating sleeves. You must be satisfied or money back. You get, 10 30 mfd. 450 volt, 4 150 mfd. 450 v, 3 20 mfd. 150 volt and 2 40 mfd. 150 volt condensers. Shipping weight 2 lbs. Deal #RN-PLI-9, Net \$7.50.

**25-WATT TRUMPET AND DRIVER \$16.95**  
 Full 12-month guarantee on this 25 Watt, all-weather re-entrant type, 15 Ohm impedance, 9" Bell diameter, 9 1/2" length. Made by a famous speaker manufacturer. New 1951 production, offered to you at a tremendous saving. Ideal for a deluxe paging speaker as well as general P.A. use. Complete with adjustable mounting bracket. Shipping weight 6 lbs.

**SUB-STATION FOR ABOVE INTERCOMS \$3.95**  
 Model MG-300 molded walnut plastic sub-station with call-back switch and heavy PM speaker, 5 1/2 x 8 1/2 x 3 1/2", for wall or desk. Weight 2 lbs. Net, \$3.95 each; 5 for \$18.95.  
 3 wire intercom cable, plastic, \$1.95 per 100 ft.; 500 ft., \$9.50.

**10 FP ELECTROLYTICS DEAL RN-10DS \$3.49**  
 10 assorted F.P. aluminum can electrolytics. Popular tap mounting. Mostly multiple section banks, 150, 350 and 450 volts. A red hot deal. Shipping weight 2 lbs. Deal #RN-10DS, Net \$3.49.

**10 BOXES OF PILOT LIGHTS \$5.49**  
 Pilot lamps, boxed 10 to a handy carton. American made. 7 boxes #47, 1 box #40, 1 box #44 and 1 box #46. A total of 100 lamps. Deal #CM-51, Net \$5.49.  
 100 #47 imported panel lamps. Guaranteed, 100 to the carton. Deal #RN-147, Net \$4.49.

**30-WATT TRUMPET and DRIVER \$28.95**  
 Model XX100-RM35. The finest trumpet driver combination value that we know. You get a full 30 Watt, 15 Ohm, PM Driver, guaranteed for 12 months and a 3 1/2 ft. spun aluminum trumpet. (Bell diameter 18", air column 3 1/2 ft., 10" overall length.) Both driver and trumpet have standard threads. (1 3/4 x 18) Driver is completely weather and waterproof. This is not surplus, but the latest 1951 production, by a famous speaker manufacturer. Trumpet furnished complete with adjustable mounting bracket. Model RM-35, 30 Watt Driver unit only, shipping weight 6 lbs. Net price, \$15.95.  
 XX-100, 3 1/2 ft. Trumpet only, shipping weight 15 lbs. Net price, \$13.95.  
 XX100-RM35, combination trumpet and driver complete. Net price, \$28.95.

**SUPER HEAVY DUTY 10" PM \$6.95**  
 We made a special purchase on several hundred 20 watt, 10" 32 oz. Alnico 3 magnet PM speakers. Deep throat and easy moving cone. Ideal for all high fidelity sound systems and radio replacement. The 20 mfd. 150v. 25 25v. FP cond. 1 x 2" 24 49 8 mfd. 450v. FP cond. 1 x 3" 29 49 20-20 mfd. 150v. FP cond. 1 x 2" 29 49 40 mfd. 150v. 200 10v. FP cond. 1 x 2" 29 49 30-30 mfd. 150v. FP cond. 1 x 2" 29 49 40-20 mfd. 150v. FP cond. 1 x 2" 29 49 80 mfd. 150v. FP cond. 1 x 2 1/2" 29 49 50-50 mfd. 150v. 25 25v. FP cond. 1 x 2 1/2" 29 49 80-40 mfd. 150v. FP cond. 1 x 3" 29 49 80-40 mfd. 150v. 25 25v. FP cond. 1 x 3" 29 49 40-40-20 mfd. 150v. FP cond. 1 x 3" 29 49 15-15 mfd. 150v. 1200 1/4 v. FP cond. 1 x 2" 29 49 30 mfd. 250v. FP cond. 1 x 2" 29 49 40 mfd. 250v. FP cond. 1 x 2" 29 49 15-15 mfd. 250v. FP cond. 1 x 2" 29 49 40-20 mfd. 150v. 100 15v. FP cond. 1 x 3" 29 49 30-50 mfd. 150v. 20 50v. 100 10v. FP cond. 1 1/2 x 2" 49

**3-Station Intercom Master \$16.95**  
 Model 2700 3-station intercom master, in an attractive walnut cabinet 10x5 1/2 x 10 1/2. Push button for each sub and talk-listen switch and volume control. AC-DC amplifier with lots of power and full size Alnico V PM speaker. 1950 production of a famous factory. Only 300 left, weight 7 lbs. Model 2700, net, \$16.95.

**50 8 MFD. 450 VOLT COND. MONTHLY SPECIAL \$16.95**  
 McGee's serviceman's monthly special for April. You get 50 of our regular 39c MN-8 MFD 450 Volt Tubular Electrolytics for only \$16.95. Full one-year guarantee. Tubular construction with cardboard insulating sleeves. Fresh stock 1951 production. 2nd to none. Shipping weight 3 lbs. Deal No. RN-50 50 8MFD 450 Volt Tubulars for \$16.95.

**12" 32 OZ. PM SPEAKER \$1.95**  
 12", 32 oz. magnet, 20 watt PM speaker, with 8 ohm voice coil. A regular \$17.00 list Consolidated speaker. Weight 8 lbs. No. CN-1232, \$7.95 each, 4 for \$29.95.

**BIG SALE ALUMINUM CAN ELECTROLYTICS**  
 McGee offers you Nationally known brands of FP type electrolytic condensers at a tremendous saving. After these are gone, we don't know where we can buy any more to sell at these prices. Order a good supply now. Unconditionally guaranteed.

**McGee's Super High Fidelity Best Value in U.S.A. OUTPUT TRANS. \$7.95**  
 Model A-403 High fidelity output transformer. Why pay \$20 or \$30 for an output, when our A-403 is available at \$7.95? Impedance, 6000 ohms plate to plate, for PL 6L6 or 6V6; 10% feedback winding, 4-8 15-250 and 500 ohm secondary. Housed in a potted case. Net weight 6 lbs. Recommended for all amplifiers up to 34 watts.

**V.M. 3 SPEED Record Changers \$24.95**  
 VM Model 408 deluxe 3 speed automatic record changer—plays them all—intermixes records of the same speed—equipped with a flip over crystal pickup with twin needles—a very sleek designed record changer—base size 12 1/2 x 13 1/2. Ship. weight 12 lbs. Net \$24.95. Buy the VM-950 changer with or without base. Choice of G.E. VR or crystal cartridge. We think the VM-950 record changer is the finest in America. It automatically plays all records all speeds and all sizes; 12 1/2-in., 3 3/4 or 7 8 rpm, 10 1/2-in., 33 1/3 or 7 8 rpm and 12 and 10-in. records of the same speed intermixed. 12 7-in., 33 1/3 or 12 7-in., 45 rpm. Automatic shut-off after the last record. Size 13 1/2 x 7 1/2 x 7 1/2 in. high. Offered with crystal cartridge, G.E. VR cartridge, or either with a base. VM-950, 3 speed changer with standard output cartridge and needles for 1 and 3 mil. (78 rpm, 33 1/3 and 45 rpm.) Net \$24.95.  
 VM-950GE, 3 speed changer with the new RPX-050 magic button, all-in-one variable reluctance cartridge with stylus. Net \$32.60.  
 VM-955GE, 3 speed changer with crystal cartridge on a base, change with stylus. Net \$35.19.

**Special Sale Buy PM Speakers and Baffles for Less at McGee**  
 Combination offer. Buy a speaker and baffle at the same time and save money. Baffles are all plywood construction with Brown Leatherette covering and are the standard mounting type.

6 inch baffle and 6" PM	Stock No.	\$4.79
8 inch baffle and 8" PM	8-CR	5.49
10 inch baffle and 10" Heavy duty	10-CR	8.95
12 inch baffle and 12" Heavy duty	12-CR	9.95
3 1/2" discount on above speaker/baffle combinations on orders of 3 or more.		

**UNIVERSAL OUTPUTS**  
 Universal replacement output transformers, for push-pull or single plate, 2500 to 13,000 ohms, from 2 to 16 ohm voice coil. Standard size 2 x 2 mounting with long leads and lugs for voice coil connections.

U-5, 5 watt universal	1.19
U-8, 8 watt universal	1.79
U-15, 15 watt universal	1.39
U-20, 20 watt universal	1.79

5 watt, single universal output transformer. Any tube to 3.2 ohm voice coil. It pays to have some of these around the shop. They come in handy. No. J3-4, ea. 79c; 10 for \$7.50; 25 for \$17.50.

**4-PRONG VIBRATORS \$1.29**  
**10 FOR \$11.90**  
 4 MILLION AUTO RADIOS BUILT IN 1950 AND HERE IS THE PERFECT REPLACEMENT VIBRATOR FOR THEM. Latest 1951 production by a top quality manufacturer. Fully guaranteed six months. Quiet running. A result of modern vibrator engineering and research. Replaces Motorola, Chrysler and any standard 4 Prong non-sine vibrator. McGee contracts for a tremendous quantity to take care of you in 1951 need. Stock #4-23 Standard 4-Prong Vibrator \$1.29 each, 10 for \$11.90. Offset 4 Prong for Delco, etc., \$1.39 each, 10 for \$12.90.  
 Buick Replacement same as Delco 5030500. Fits all Buicks, 1937 thru '47, etc. \$1.95 each, 10 for \$17.90.  
 Mallory 534C 4 Prong Reversible Synch. \$1.95 each, 10 for \$17.90.  
 Offset 4 Prong for Delco, etc., \$1.39 each

**2-STATION INTERCOM \$16.95**  
 Complete, top quality two station intercom system, \$14.95. With 50 feet of connecting cable. New 1951 production, housed in matching walnut plastic case. Master has push-to-talk switch. May be used on wall or desk or floor secondary. Guaranteed using 12G-7, 50L6 and 35Z5 tubes. Stock No. MC-2S, weight 8 lbs. Net price \$16.95. Extra sub station may be used with other sub as a non-selective 3 station system. \$3.95.

**PHONO MOTOR \$3.95**  
 9" Turntable heavy duty 78 RPM 110 Volt 60 Cycle, phono motor with heavy 1 1/2 lb. turntable 4 pole motor. Don't confuse this with ordinary motor. Shipping weight 5 1/2 lbs. Stock #GS-87, Net \$3.95, 10 for \$10.00.

**McGee's Super High Fidelity Best Value in U.S.A. OUTPUT TRANS. \$7.95**  
 Model A-403 High fidelity output transformer. Why pay \$20 or \$30 for an output, when our A-403 is available at \$7.95? Impedance, 6000 ohms plate to plate, for PL 6L6 or 6V6; 10% feedback winding, 4-8 15-250 and 500 ohm secondary. Housed in a potted case. Net weight 6 lbs. Recommended for all amplifiers up to 34 watts.

**RED HOT ELECTROLYTIC SPECIALS**  
**ORDER 100 ASSORTED FOR \$37.50**  
 Stock No. EC-4, Capacity 40-40-20, voltage 150V, 82c each  
 Stock No. EC-512, Capacity 50-50, 200 voltage 150V, Net each, 40c  
 Stock No. EC-3132, Capacity 40-40, 200; voltage 150-150, Net each, 40c  
 40-40, 200; voltage 150-150, Net each, 40c  
 Tubulars in cardboard tubes with long flexible leads. Fully guaranteed, 10,000 to sell at this bargain price.

**McGee's Super High Fidelity Best Value in U.S.A. OUTPUT TRANS. \$7.95**  
 Model A-403 High fidelity output transformer. Why pay \$20 or \$30 for an output, when our A-403 is available at \$7.95? Impedance, 6000 ohms plate to plate, for PL 6L6 or 6V6; 10% feedback winding, 4-8 15-250 and 500 ohm secondary. Housed in a potted case. Net weight 6 lbs. Recommended for all amplifiers up to 34 watts.

**McGEE RADIO COMPANY**  
 Prices F.O.B. K.C. Send 25% Deposit with Order, Balance Sent C.O.D. With Parcel Post Orders, Include Postage

**McGEE RADIO COMPANY**  
 Prices F.O.B. K.C. Send 25% Deposit with Order, Balance Sent C.O.D. With Parcel Post Orders, Include Postage

**McGEE RADIO COMPANY**  
 Prices F.O.B. K.C. Send 25% Deposit with Order, Balance Sent C.O.D. With Parcel Post Orders, Include Postage

**McGEE RADIO COMPANY**  
 Prices F.O.B. K.C. Send 25% Deposit with Order, Balance Sent C.O.D. With Parcel Post Orders, Include Postage

**McGEE RADIO COMPANY**  
 Prices F.O.B. K.C. Send 25% Deposit with Order, Balance Sent C.O.D. With Parcel Post Orders, Include Postage

**McGEE RADIO COMPANY**  
 Prices F.O.B. K.C. Send 25% Deposit with Order, Balance Sent C.O.D. With Parcel Post Orders, Include Postage

**McGEE RADIO COMPANY**  
 Prices F.O.B. K.C. Send 25% Deposit with Order, Balance Sent C.O.D. With Parcel Post Orders, Include Postage

**McGEE RADIO COMPANY**  
 Prices F.O.B. K.C. Send 25% Deposit with Order, Balance Sent C.O.D. With Parcel Post Orders, Include Postage



# USE PHOTOFAC

the world's best Radio-TV service data—it pays for itself every working day



Try PHOTOFAC!

**FREE**

We'll send you any Photofact Folder listed in the Photofact Cumulative Index

WE'LL PROVE YOU'LL SAVE TIME and EARN MORE WITH PHOTOFAC

NOW—learn for yourself—at our expense—how PHOTOFAC makes your Radio and TV work quicker, easier, more profitable! Examine an actual PHOTOFAC Folder. Use it. You'll learn first-hand why over 35,000 successful service technicians use PHOTOFAC daily. You'll learn that no other service gives you PHOTOFAC's completeness, accuracy, uniformity, and lowest cost. PHOTOFAC is the only radio and TV service data prepared from laboratory analysis of the actual equipment. Know the facts—get your FREE Folder now. Examine, use, compare—learn why no modern service shop can afford to be without PHOTOFAC!

WRITE FOR FREE INDEX

PAY AS YOU EARN! Ask your distributor about this amazing plan. Only \$18.39 puts the entire profit-boosting Photofact library in your shop now!

**NOTE:** Our FREE Folder offer is limited to Service Technicians only. Attach coupon below to your letterhead and mention your jobber's name. If you have no letterhead, send coupon to your jobber. Experimenters and others may obtain the Photofact Folder by remitting amount shown below.

HOWARD W. SAMS & CO., INC.  
2201 E. 46th St., Indianapolis 5, Ind.

- Send FREE Photofact Cumulative Index
- Send Full Easy-Pay Details

I am a Service Technician:

- Send FREE Folder for set model.....

I am an Experimenter: Enclosed \$.....

- Send Folder for set model.....
- TV-\$1.00, Record Changer or Comm. Receiver-75c, AM/TM-50c

Name.....

Address.....

City.....Zone...State.....

## Speaker Cabinets

(Continued from page 56)

net wall has been completely eliminated. The sharpness of the edge has also been reduced which mitigates the diffraction effects due to this edge. The response frequency characteristic of a loudspeaker mechanism mounted as shown in Fig. 9B is shown in Fig. 10A(b). Comparing the response frequency characteristics of Figs. 10A(a) and 10A(b), it will be seen that a considerable improvement in response can be obtained with the mounting arrangement shown in Fig. 9B.

Subjective tests made upon the effect of the mounting height of the loudspeaker mechanism indicate that the most pleasing results are obtained when the top edge of the loudspeaker mechanism is located near the ear level. Therefore, every effort should

be made to mount the loudspeaker as near this level as possible. Since most of the serious listening is done while the listener is seated, the average ear level is 38 to 44 inches. The upper edge of the loudspeaker mechanism in the cabinet of Fig. 6 is about 38 inches above the floor. The mounting height of the loudspeaker mechanism in this cabinet satisfies the mounting height requirements.

### Cabinet Configuration

The outside configuration of the cabinet influences the response due to the diffraction effects introduced by the sharp discontinuities introduced by the edges of the cabinet.

The most common cabinet for mounting loudspeaker mechanisms is a rectangular parallelepiped as shown in Fig. 11. The loudspeaker mechanism is usually mounted near the top end of the cabinet.

The cubic content of the cabinet

Fig. 10. Response frequency characteristics of a 15" direct radiator loudspeaker mechanism mounted (Aa) as shown in Fig. 9A in the cabinet of Fig. 6; (Ab) as shown in Fig. 9B in the same cabinet. The RCA Types LC1A, 515S1, and 515S2 duo cone loudspeaker mechanisms are designed for flush mounting in the wall of the cabinet. (Ba) Response frequency characteristic with speaker mounted in cabinet of Fig. 11, with cabinet walls made of the same thickness material as shown in Fig. 6. Stiffeners were used on all inside walls. The inside of cabinet was treated with damping material. The loudspeaker was mounted flush with front of cabinet as shown in Fig. 9B. The only essential difference between cabinets of Figs. 6 and 11 is outside shape. (Bb) Response of speaker mounted in cabinet of Fig. 6. (C) Response of same speaker in cabinet of type shown in Fig. 11. In this cabinet design all precautions for obtaining smooth response were purposely ignored to show what the result would be. Deviations from good design included a rectangular parallelepiped outside shape, thin and unbraced walls, untreated inside walls, and speaker mounted on back of front cabinet wall as shown in Fig. 9A.

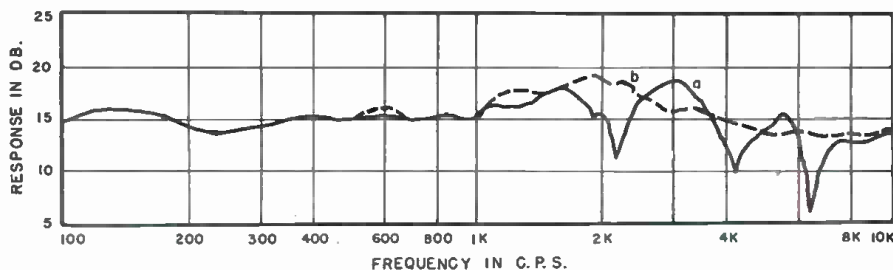

(A)

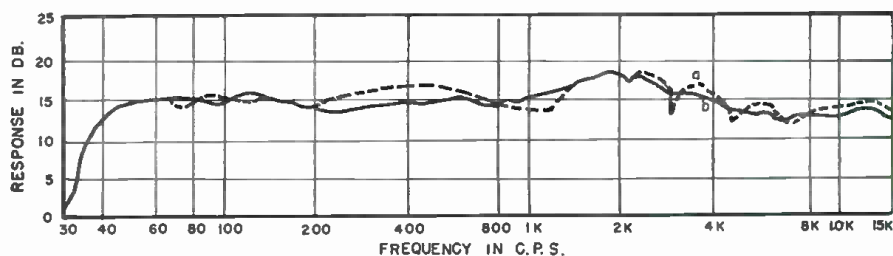

(B)

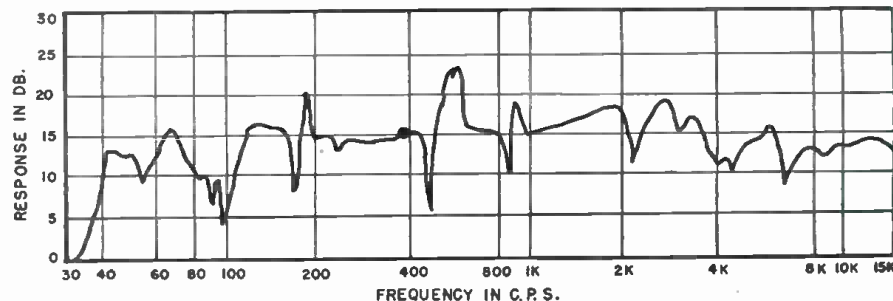

(C)

# OUTSTANDING VALUES NOW AVAILABLE

## ORDER AUTO RADIO PARTS AND EQUIPMENT NOW!

### AUTO ANTENNAS

**TOP COWL:** 3 section staff, 58" extension. Bakelite insulator, chrome trim. Single hole mount. Simple installation. Complete with lead. **\$2.19** each. Case of 25.....**\$1.95** each

**SIDE COWL:** 3 section staff, 63" extension. Complete with tenite insulators. Static ball and tip shielded. Low loss lead.

**\$1.89** each. Case of 25. **\$1.75** each

### STANDARD MANUFACTURE VIBRATORS

Standard 4 prong.....**\$1.45** each.  
10 for.....**\$14.00**

Offset 4 prong—Delco type. **\$1.55** ea.  
10 for.....**\$15.00**

Buick type 5 prong.....**\$2.95** each.  
10 for.....**\$28.00**

Generator Condensers.....**25c** each  
10 for.....**\$2.20**

### BUFFER CONDENSERS

.005 —2000 V... } **25c** each  
.006 —1600 V... } 10 for **\$2.25**  
.0075—2000 V... }  
.01 —2000 V... } 100 for **\$19.50**

### GUARANTEED RECTANGULAR PICTURE TUBES

A real bargain for these first-rate tubes.

16"—16RP4.....**\$25.50** each  
17"—17BP4.....**\$26.50** each  
20"—20CP4.....**\$45.00** each

**PHONO CARTRIDGES**—Brand New—Will replace 95% of all cartridges.  
1 volt—Standard Mounting. **\$1.75** ea.  
3 volt—Standard Mounting. **\$1.85** ea.

### GT TUBE CARTONS

**Sturdy—Many Uses**

Box bulk tubes, spare parts, nuts and bolts. **79c** per 100. **\$4.95** per 1000.

**CHIMNEY MOUNTS**—2 piece heavy-duty, rust-proof brackets. No drilling or guy wire needed. Includes strapping. **\$1.45** each 12 for **\$1.30** each

## NOW! LARGE 14" or 17" PICTURE FROM YOUR 10" or 12" TELEVISION SET

Servicemen: Convert customers' sets for extra profits! 90% of all conversions can be made by use of the RAPARCO conversion kit.



**14" Kit**—14BP4 CR tube, 70° Deflection yoke. Attractive Lucite mask. **\$32.95**

**17" Kit**—17" Rectangular CR tube, 70° Deflection yoke. Attractive Lucite mask, 17" HV Flyback transformer.....**\$39.95**

### TV COMPONENTS

Standard Manufacture. All New. All Guaranteed.

16" to 19" HV Flyback transformer, Single filament.....**\$4.50** ea.  
16" to 19" HV Flyback transformer, Double filament.....**\$4.50** ea.

GE type 16" to 19" Flyback transformer.....**\$4.50** ea.  
Vertical Output transformer. **\$1.59** ea.

500 MMFD—20 KV. **\$1.11** ea., 10 for.....**\$10.00**  
500 MMFD—10 KV. **79c** ea., 10 for.....**\$7.00**

Single Magnet Ion traps **49c** ea., 10 for.....**\$4.50**

Double Magnet Ion traps **79c** ea., 10 for.....**\$7.50**

.001 MFD—6 KV Condenser **59c** ea., 10 for.....**\$5.50**

.005 MFD—6 KV Condenser **59c** ea., 10 for.....**\$5.50**

14" Attractive Lucite mask, Gold trim.....**\$3.95**

16" Attractive Lucite mask, Gold trim.....**\$4.50**

19" Attractive Lucite mask, Gold trim.....**\$5.25**

20" Attractive Lucite mask, Gold trim.....**\$5.95**

## CUSTOM BUILT AUTO RADIOS

Easily installed. Fine, top quality. Ready to place in your car. Designed for each specific car.

**All sets—6 tube.** 3 gang; super heterodyne. Extra sensitive circuit. Low battery drain. Beautiful finish and d.o.l. These models now available:

1951—Ford	1948-49-50-51—Hudson
1949-50—Ford	1951—Henry J
1951—Chevrolet	1951—Dodge, Plymouth
1949-50—Chevrolet	1949-50—Dodge, Plymouth
1950-51—Studebaker	

List Price, **\$59.95**

**YOUR PRICE.....\$41.95**

### CONICAL TV ANTENNAS

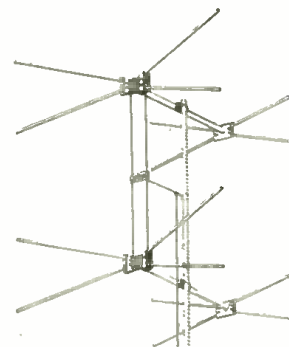

Case of 6 antennas.....**\$23.70**  
Stacked conicals including stacking bars (as pictured). Case of 3 complete stacks.....**\$25.35**

4 ft. TV Antenna Mast—Heavy Gauge Steel—rustproof coating. 1 1/2 OD. **\$1.25** each. 10 for.....**\$11.50**

### INDOOR TELEVISION ANTENNA



Now TV reception without the outdoor antenna. Effective range 20 to 25 miles from station. Excellent reception. Easily installed—takes 5 seconds. Easily orientated. Heavy base—will not tilt. Attractive. Friction clutch-type action on the rods. Complete with lead in.....**\$2.49**  
Case lots of 25.....**\$2.25**

**Radio Parts Company, 614 RANDOLPH ST., CHICAGO 6, ILL.**

The Hottest  
item since  
the picture  
tube!



the  
**TURRET  
BOOSTER**

- Operates on Intermediate Frequency— one setting for all channels.
- Removed or installed without disrupting wiring of set.
- Fully concealed within set—no exterior units.
- Improves reception—increases video output 15% upwards.
- Improves receivers having poor sound (Emphasis placed on sound by IF coil adjustment.)
- Comes on when receiver is on—no extra switches to complicate the tuning of the receivers.

\*Less additional tube.

WRITE FOR  
FURTHER  
DETAILS

Money Back  
Guarantee

**BARB-CITY INDUSTRIES, Inc.**  
1152 FOURTH ST.      DEKALB, ILL.

shown in Fig. 11 is approximately the same as that of the cabinet of Fig. 6. The walls of the cabinet were made of the same material as that of Fig. 6. In addition, bracing strips were used on the large flat surfaces. The damping material was the same as that used in the cabinet of Fig. 6. The loudspeaker mechanism was mounted flush with the front of the cabinet of Fig. 11. With these precautions, the essential difference between the cabinets of Figs. 6 and 11 is the outside configuration. The response frequency characteristic of a wide range loudspeaker mechanism mounted in the cabinet of Fig. 11 is shown in Fig. 10B(a). The response frequency characteristic of the same loudspeaker mechanism mounted in the cabinet of Fig. 6 is shown in Fig. 10B(b). The characteristics shown in Figs. 10B(a) and 10B(b) show the deleterious effects of the diffraction from the symmetrical mounting of a loudspeaker mechanism in a rectangular parallelepiped. The physical explanation is as follows: Sound waves spread out in all directions from the loudspeaker mechanism. As the sound waves strike the sharp discontinuity at the edges of the cabinet, they are diffracted. The diffracted waves are sent out in all directions and, depending upon the phase between primary and reflected waves, either add to or subtract from the primary waves produced by the loudspeaker. As a result, corresponding variations in the response are produced due to the interaction between the primary and secondary waves. In the cabinet of Fig. 6 the sharp edge discontinuities have been reduced, which minimizes the reflection and diffraction effects.

As a final check, all of the precautions necessary for obtaining smooth response as outlined in this article

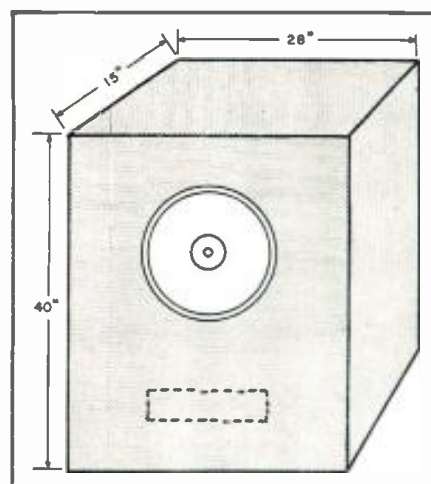

Fig. 11. Perspective view of a cabinet having the shape of a rectangular parallelepiped. The dimensions given yield the same volume as the cabinet shown in Fig. 6.

were purposely ignored to show what the result would be. A wide range loudspeaker mechanism was mounted in a cabinet of the rectangular parallelepiped type shown in Fig. 11. The walls were made of thin wood. The inside of the cabinet was not braced. There was no damping material used on the inside of the cabinet. The loudspeaker was mounted back of the cabinet wall, that is, not flush with the front of the cabinet. The same wide range loudspeaker mechanism used in all the tests reported herein was mounted in this cabinet. The response frequency characteristic obtained on this combination is shown in Fig. 10C. Comparing the characteristics of Figs. 10B(b) and 10C shows that the response of a good loudspeaker mechanism may be ruined by a poorly designed and built cabinet.

-30-

**ANOTHER TELEVIEWER BRINGS THEM IN!**

**A**DDITIONAL reports of television reception from distant stations and under unusual conditions continue to drift into our editorial offices, the latest being a log from Harrison King of Savannah Beach, Georgia.

Mr. King's home is approximately 18 miles east of Savannah. The nearest television transmitter is located in

Jacksonville, Florida, about 120 miles away. The terrain is flat.

He has a Fada Model TV 30 with an Astatic booster. His antenna, which is mounted on top of a 45 foot roof, is a Vee-D-X, double-stacked and cut for Channel 4. The rotator is an Alliance unit.

-30-

STATION	CITY	DISTANCE	CHANNEL NO.	RECEPTION
WMBR-TV	Jacksonville	120	4	Good
WBTV	Charlotte	210	3	Fair
WAGA-TV	Atlanta	210	5	Fair
WSB-TV	Atlanta	210	8	Fair
WBRC-TV	Birmingham	330	4	Good (on occasion)
WTVJ	Miami	400	4	Good (on occasion)
WNBW	Washington	475	4	Good (on occasion)
WPTZ	Philadelphia	585	3	Good (on occasion)
WNBK	Cleveland	610	4	Good (on occasion)
WWJ-TV	Detroit	660	4	Good (on occasion)
WBNT	New York	650	4	Good (on occasion)
WBEN-TV	Buffalo	700	4	Good (on occasion)
WOC-TV	Davenport	775	5	Fair (on occasion)
WHBF-TV	Rock Island	775	4	Good (on occasion)
WTMJ-TV	Milwaukee	775	3	Fair (on occasion)
WBZ-TV	Boston	820	4	Very good (on occasion)
WNAC-TV	Boston	820	7	Fair (seldom received)
WDAF-TV	Kansas City	825	4	Very good (on occasion)
KRLD-TV	Dallas	845	4	Fair (seldom received)
WKY-TV	Oklahoma City	890	4	Good
WOAI-TV	San Antonio	950	4	Good
WOI-TV	Ames	960	4	Very good (most often received)
WOW-TV	Omaha	960	6	Fair (seldom received)
WTCN-TV	Minneapolis	1020	4	Good (on occasion)



# STOP DREAMING!



# START PLANNING!



## CREI Can Help You **EARN MORE MONEY** with practical training in **TELEVISION** *and FM* **SERVICING!**

### Learn Now How to **INSTALL** and **SERVICE** All Types of TV & FM Receivers!

**Q**UALIFIED SERVICEMEN are getting harder and harder to find—at the very time that civilian needs are at their highest point. With ever-mounting sales of television sets, with the electronics industry expanding, and with growing military demands cutting sharply into the available supply of skilled technicians, now is certainly the time to make the most of your opportunity. TV—FM specialists are in great demand. Whether you have your own repair business, or work for someone else, CREI Home Study can mean more money for you.

This specialized servicing course is the practical answer to the technical problems that bother the average serviceman when he faces the job of servicing today's intricate TV and FM equipment. Every lesson in the

course is practical and helpful in your daily work. Lessons are revised as new developments are accepted by the industry. This training takes you out of the time-consuming "hit-and-miss" methods—gives you the profitable, *quick* trouble-shooting techniques. The sooner you begin your training, the better off you'll be! Write for free data now. The course cost is nominal, the terms easy.

**NOTE TO MEN WHO EXPECT TO BE IN UNIFORM SOON:** *TV-electronics training is excellent background for vitally important radar, communications and navigation work in the Armed Services. If you expect to enter service, prepare now to qualify for a higher rating in interesting technical work.*

#### THE THREE BASIC CREI COURSES:

- ★ **PRACTICAL RADIO ENGINEERING**  
*Fundamental course in all phases of radio-electronics*
- ★ **PRACTICAL TELEVISION ENGINEERING**  
*Specialized training for professional radiomen*
- ★ **TELEVISION AND FM SERVICING**  
*Streamlined course for men in "top-third" of field*

ALSO AVAILABLE AS RESIDENCE SCHOOL COURSES

### **CAPITOL RADIO ENGINEERING INSTITUTE**

*An Accredited Technical Institute Founded in 1927*  
Dept. 115C, 16th & Park Rd., N. W., Washington 10, D. C.  
Branch Office: San Francisco, 760 Market St.

#### MAIL COUPON FOR FREE BOOKLET

**CAPITOL RADIO ENGINEERING INSTITUTE**

Dept. 115C, 16th & Park Road, N. W., Washington 10, D. C.

Gentlemen: Send booklet, "Your Future in the New World of Electronics," together with details of your home study training, CREI self-improvement program and outline of course. I am attaching a brief resume of my experience, education and present position.

Check Field of Greatest Interest:

Practical Television Engineering

Aeronautical Radio Engineering

Practical Radio Engineering

Broadcast Radio Engineering

(AM, FM, TV)

TV, FM & Advanced AM Servicing

Radio-Electronics in Industry

II Residence School in Wash., D. C. Preferred, Check Here

NAME \_\_\_\_\_

AGE \_\_\_\_\_

ADDRESS \_\_\_\_\_

CITY \_\_\_\_\_

ZONE \_\_\_\_\_

STATE \_\_\_\_\_

# OLSON AKRAD

**Olson Radio Warehouse, Inc.**  
73 E. Mill St. • Akron 8, Ohio

FREE—SEND FOR OUR LATEST RADIO AND TELEVISION BARGAIN CATALOG



## RCA VICTOR NON-BREAKABLE RECORDS INCLUDED.

Yes, with the phonograph you get approximately \$10.00 worth of RCA Victor non-breakable discs for children. Titles include "Happy the Humbug," "The 500 Hats of Bartholomew Cubbins," "Rapunzel," "Aladdin and His Lamp," etc. Discs are enclosed in beautifully illustrated colored folders giving each story so that the child can follow the recording. Quantity Limited—ORDER NOW!

## GIANT COMBINATION DEAL

\$10 Worth of RCA Records and Phonograph

**\$19<sup>97</sup>**  
RA-60

Compact beautifully performing phonograph for all 78 RPM records. Amplifier employs 2 tubes, 50-L-6 and 35-Z-5. Only the finest components are used, such as Alliance Rim-Drive Motor, Astatic Phono arm with L-82 cartridge, PM speaker, full range volume control, etc. The case is decorated with colorful circus figures. Operates on 115v. AC. Weight 11 lbs.

## AMPLIFIERS

Latest models. Incorporates dual tone controls for Bass and Treble. Input for crystal, ribbon or dynamic mike and phono. Output Impedances, 4, 8, 15 and 500 ohms. Less tubes.  
RA-28 15 Watt Model... \$21.95  
RA-23 30 Watt Model... \$34.95

## BUY ALL YOUR RECORDING NEEDS FROM OLSON

### STEEL RECORDING WIRE



For all standard wire recorders. Frequency response is excellent. Stainless steel wire.  
X-165 1/2 hr. spool... \$1.98  
X-166 1 hr. spool... \$2.98

### Tape

Fine magnetic recording tape. Frequency response, 50 to 8,600 cycles at 7 1/2" per second. Uniformly coated with red oxide. Available in paper base and plastic base which is stronger. Order your recording tape from Olson. Get the best for less.

Stock No.	Size	Type	Olson's Price
X-203	1/4" x 800 ft.	Paper	\$1.35
X-204	1/4" x 800 ft.	Plastic	2.10
X-205	1/2" x 1200 ft.	Paper	2.10
X-206	1/2" x 1200 ft.	Plastic	3.30

## AC LAMP CORD

WHILE THE SUPPLY LASTS

Ever popular brown zip-cord for any AC appliance, lamp or radio. Two conductors, stranded copper, tough insulation.  
W-53, 250 ft. spool... ea. \$4.99  
W-69, 500 ft. spool... ea. \$8.99



## EXACT REPLACEMENT GE NEEDLES

USED IN ALL GE VARIABLE RELUCTANCE CARTRIDGES  
No service shop, large or small, should be without a stock of these popular replacement needles. The three types listed below will take care of all General Electric Variable Reluctance Phono Cartridges.

Equipped with GENUINE Sapphire tips. 100% guaranteed. Beautifully packaged. Order some of each today and be ready for this profitable needle replacement business.

Stock No.	GE Type	Cartridge No.	Tip	Your Cost
N-32	RPJ-001	RPX-040, RPX-041, RPX-046	3 MIL	\$2.06
N-33	RPJ-005	RPX-041, RPX-046	1 MIL	\$2.06
N-34	RPJ-010	EPX-050	DUAL	\$3.50



**MUSICAL INSTRUMENT MIKE**  
M-61 \$6.95

Famous quality! Sells for twice our sale price. Easily attached. Delivers brilliant tone from string instruments. With 4' shielded cable and volume control.



**RCA 8" PM SPEAKER**  
S-123 \$3.99 EACH

Known as the RCA "Mighty 8." Delivers tremendous volume because of advanced engineering design and super-size Alnico 5 magnet. For radio and PA use. Voice coil 3.2 ohms. SHPK. wt. 6 lbs.

**Build a Receiver Set of Basic Components**  
Kit of 5 parts... AS-38  
You get this kit for \$1.89  
DC set or portable:  
Parts Reg. List Price  
Loop... \$0.95  
R. F. Coil... 1.10  
I.F. Transformer (450 KC) Input... 1.60  
Output... 1.60  
Oscillator Coil... .75  
List Price of Set... 6.00  
Use any 365 mfd variable for tuning. Covers 535-1625 KC.

## ASTATIC PROFESSIONAL

Has all advantages of low pressure design. For Broadcast and Recording Studio use. Ball bearing swivel base, accurately counter balanced arm for one ounce needle pressure. Plays up to 16" discs. Astatic Model No. EP-16. Overall length 13 in. Equipped with Astatic LP-21 cartridge and precious tipped stylus. Regular list price \$25.00.  
Stock No. M-72, each \$5.95

## FP CONDENSER KIT

Assortment of 15 popular FP condensers, double and triple sections. Capacities from 10 mfd to 50 mfd; from 25 to 450 volts. Shpg. wt. 3 lbs.  
OLSON'S BARGAIN AS-24, each \$3.98

## 4-DRAWER STEEL CHEST

For small parts, etc. Knob on each drawer; various size compartments.  
Each drawer 1 1/2" deep. Sizes: 6 1/2" H., 5 1/2" W., 8 1/2" D. Shipping weight 5 lbs.  
RA-19 \$2.19 X.195



**PHONO AMPLIFIER**  
Connect to phono or speaker or just the thing for a portable. Uses: 129Q7, 50L6, 35Z5 tubes. 2 controls; on/off volume and tone. 7"x3 1/4"x2". SBPPE. wt. 2 lbs.  
TUBES FOR ABOVE \$2.64  
NET. AS.22

## TV INSTALLATION MEN

If you install TV Antennas, Olson wants you to take advantage of this terrific Antenna Value. High gain Stacked Conical Array with high frequency stubs. Ideal for "Fringe" Area Reception. Sturdily constructed, elements are aluminum. Easily assembled.  
**This is a Terrific Value!** Each Antenna consists of two conical arrays of a pair of matching Q bars. Less mast. Packed-3 Antennas to a carton. This gives you six bays and 3 pairs of Q bars.  
Sold Only in Boxes of 3 Antennas  
AU-66. Carton of 3... \$866  
In lots of 3, each... \$25.98  
Weight 25 lbs.

## POPULAR TV COMPONENTS

These TV Parts are made by famous name manufacturers. A lucky Purchase makes possible these bargain prices. Stock up now. Each part shown here uses Alnico 5 magnet material which is practically impossible to obtain. Get your share of these scarce components at far less than wholesale.

## EM-PM FOCUS COIL

**T-90 Special. White they last, each... \$2.98**  
Latest style combination EM-PM type requiring less power than the straight EM coils. Uses a very heavy Alnico 5 magnet thereby maintaining a more constant focus. This focus coil is used in scores of TV sets including General Electric, Sylvania, Carlsen, Air King and many more. Can be used on all 16"-70" and 18"-66" Kinescopes. Here's a real value. Buy now and save. Because of the shortage of Cobalt these will not be available after our present stock is gone.

## ION TRAP

**T-91 Special. White they last, each... 98¢**  
Well made ion trap with two powerful Alnico 5 magnets. Exceptionally well made. Bronze spring keeps trap firmly against kinescope neck. Because of the shortage of Cobalt these will not be available after our present stock is gone.

## QUAM FOCALIZERS

**T-89 Special. White they last, each... \$1.98**  
Genuine Quam-Nichols focalizers. Also known as focus magnets. Provides sharp focus relatively independent of regulation in the low voltage power supply. No connections necessary. Widely used in many 1950 models. Utilizes heavy duty Alnico 5 magnet.

## UNIVERSAL VIDEO PEAKING COILS

**L-39 package of 6 coils with instructions, per pkg... 98¢**  
Adjustable from 31 to 820 micro-henrys. No need to carry a big stock of peaking coils if you have a supply of these. Nylon insulated wire. Here's a real Olson value.

**Deflection Yoke for use with 10BP4, 12LP4, 16AP6 and all similar kinescopes, same RCA 205D1 WT. 2.2. T-84, Olson's Price, only... \$2.79**  
Deflection Yoke for use with kinescopes requiring 60 degree magnetic deflection such as Rectangular 14BP4, 14CP4, 16RP4, 16TP4, 16KP4 and 16GP4. WT. 2.2. T-86, Olson's Price, only... \$4.49

**300-Ohm Lead-in \$4.00**  
High grade, low loss. For all TV installations. Ship. wt. 3 lbs. ft. coil.

## OLSON AKRAD CRYSTAL CARTRIDGES

**3-VOLT OUTPUT**  
The crystal Phono cartridge you've been waiting for—and at a price which enables you to use them in your service work profitably. The new Olson Akrad cartridge is interchangeable with any standard cartridge since the mounting centers are 3/8". Its high output, 3 volts and wide range response of 50-6000 cps are obtained by advanced methods used in driving the crystal element. The cartridge is supplied with pin plug connectors for ease of connecting leads. Each cartridge is individually packed in a handsome red, white, and blue shelf carton. Order some of each model today.  
XC-50, Standard crystal Cartridge, each... \$1.99  
XC-51, 3-way cartridge with built-in 2 mil needle for 33 1/3, 45 and 78 RPM Discs, each... \$2.79

## AN OLSON VALUE



**12" CO-AXIAL SPEAKER**  
Woofer-Tweeter design. Response 40 to 17,500 CPS. \$13.95  
Months of research went into the design of these high efficiency speakers. The 12" woofer section is driven by a heavy Alnico 5 6.8 oz. magnet and this part delivers the bass notes. The 3" tweeter which is built into the center of the speaker is driven by a 2.15 oz. Alnico 5 magnet and delivers the treble notes. The high pass filter is built into the speaker and the entire combination gives you tone you never dreamed possible. There are only two wires to connect to any radio or amplifier and the speaker is ready to play for you. Voice coil impedance is 8 ohms. This high quality speaker should not be confused with inferior money-back guarantee if you are not 100% satisfied. Order today. Shpg. wt. 8 lbs.

## RCA "FIRE GLOW" FLUORESCENT SIGN

Bigger, brighter, and whiter. The new RCA Fire Glow has high daytime visibility and brilliant luminous white glow at night. The plastic face is three-dimensional, cased in steel. Sign stands on rubber protectors, or can be hung from ceiling with chain supplied. 110 Volt, 60 cycle AC operation. Complete with fluorescent \$8.95  
2F-985

## PANEL LAMPS

Westinghouse, GE, and Tung-Sol bayonet panel lamps. 100 of a type to the box.  
Price  
Stock No. Type No. per 100  
X-161 47 \$5.59  
X-174 44 \$5.59  
PL-25 51 \$4.29

## BATTERY ELIMINATOR

**MODEL P \$10.95**  
Each  
Converts portable battery sets to all-electric AC. Will give years of dependable, trouble-free service. Supplies 1.4 volt "A" and 90 volts "B" power for 4 to 6 tube sets.  
The most popular vibrator in use today. Replaces Mallory 29-3, 859, 901M, Radiart 3300, 3301. Size 1 1/2" dia. by 2 3/8" high. Reg. list price \$4.49. New, individually boxed. Shpg. wt. 8 oz.

## ASTATIC MICROPHONE

High output crystal mikes for PA systems and recorders. Equipped with handle base and 7' shielded cable. Shpg. wt. 5 lbs.  
M-67, each... \$5.95  
M-66, each... \$6.95  
with on/off switch built into handle... \$6.95

## 4 Prong Universal VIBRATORS

Stock No. V848 \$1.49





# HIGH FIDELITY is here!



## TWO BRILLIANT NEW CUSTOM CHASSIS —

Now, for the first time, you can enjoy the finest television and FM—plus high fidelity audio—all in one superbly-designed instrument! Now, at last, custom builders and electronics enthusiasts can choose the Craftsmen Television which best suits their needs. SEE them! HEAR them! Above all—COMPARE them!

### The RC-101

An outstanding new high fidelity custom video tuner with the same fine, big-picture quality and sensitivity as its famous predecessor, the RC-100. Features include keyed AGC and booster switch, plus new, double-shadow tuning eye for precision tuning. 20-20,000-cycle audio output permits remote hook-up with high fidelity audio and FM-AM tuners. Turret-type channel selector.

### The RC-200

Here, at last, is a TV-FM-high fidelity audio receiver which, in one chassis, combines true high fidelity television and FM reception! Has all features of RC-101, plus 5-watt, push-pull high fidelity audio system and coverage of FM band. Continuous-type tuner and tuning eye permit 1-knob control of TV, FM or phono. Both chassis finished in polished chrome.

Write for information—or send 50¢ for instructions and schematics.

THE RADIO **craftsmen** INCORPORATED

Dept. R-5, 4401 N. Ravenswood Ave., Chicago 40, Ill.

## Emergency Instrument (Continued from page 47)

strument the author didn't spend too much time in "prettifying up" the unit as it wasn't designed as a show piece for the workbench. However, this doesn't mean that it is impossible for the instrument to have a "professional" appearance.

If the technician has the time to devote to adding the finishing touches, there are a variety of "extras" that can be included which will add "class" to the front panel.

The builder can apply decals to mark the various ranges of resistance, capacitance, etc., or he can insert white

scales behind the range switches and inscribe the appropriate values in India ink on the surfaces. All of these flourishes add immeasurably to the overall appearance of the instrument.

If the unit is to be taken into customers' homes, builders are urged to take the extra time to add these refinements as the customer will be duly impressed by the "professionalism" of the test equipment the technician uses in the servicing of his radio receiver and react accordingly in his relations with the technician.

If by this time you are beginning to believe that we are fond of "Old Faithful" you would be right. The instrument has proven very helpful and always comes through when it is needed most.

-30-

Table 1. Details for using instrument for various test functions.

TEST	SECTION	SWITCH	JACKS	PROCEDURE
Capacity (paper cond.)	4	S <sub>1a</sub> —.001-.01 μfd. S <sub>1b</sub> —.01-.1 μfd. S <sub>1c</sub> —.1-1 μfd.	Condenser to A & D Voltmeter to B & C	Plug instrument line cord into line. Close switch S <sub>1</sub> . Read meter. (See text)
Condenser Substitution (paper cond.)	3	S <sub>1</sub> to desired range	Test leads to A & B	Disconnect one lead of cond. in receiver and substitute cond. through test leads
Condenser Substitution (electrolytics)	5 or 6	S <sub>1</sub> and/or S <sub>2</sub> to desired range	Test leads to A & B	Disconnect anode of cond. in receiver and substitute cond. through test leads. Observe polarity
Continuity (high res.)	2	S <sub>1</sub> to "b"	Test leads to A & B Phones to C & D	Click in phones indicates continuity
Continuity (low res.)	3	S <sub>1</sub> to any setting	Test leads to C & D	Continuity indicated if lamp lights (See text)
Electrolytic Leakage	1	S <sub>1</sub> to "b". S <sub>2</sub> to "a" for 100 v. cond. or less. S <sub>2</sub> to "b" for over 100 v. cond. S <sub>2</sub> to "b"	Disconnect cond. anode from receiver. Connect + of milliammeter to C. Connect - of milliammeter to cond. anode. Connect disconnected terminal of receiver to A	Turn receiver on. Let cond. form approx. 3 minutes. Throw S <sub>1</sub> to "a". Read milliammeter (See text)
Electrolytic Quality	2	S <sub>1</sub> to "d"	Disconnect anode of cond. from receiver. Connect phones to C & D. Connect cond. to A & B. Observe polarity.	Let cond. form approx. 3 minutes. Remove test lead from cond. cathode. Throw S <sub>1</sub> to "e". Tap neg. terminal of cond. repeatedly with lead. Clicks in phones, gradually disappearing, indicate cond. stores charge
Hum (filter circuit)	5 or 6	S <sub>1</sub> and/or S <sub>2</sub> to desired range	Test leads to A & B	Connect test leads across suspected cond. observing polarity. Reduction in hum suggests defective cond. Confirm by substitution test.
Pilot Lamp 6-8v. only	2	S <sub>1</sub> to "b"	Test leads to A & D	Test leads to lamp. Lamp should light
Resistor Substitute	3	S <sub>1</sub> to desired range	Test leads to A & B	Disconnect one end of resistor in receiver and substitute resistor through test leads
Signal Generator	7	S <sub>1</sub> to "b"	Coaxial cable probe to A	Touch probe to signal circuits of stages, working from speaker to antenna. Signal will be heard in speaker if following parts of stages are OK
Signal Tracer (audio)	1	S <sub>1</sub> to "a", S <sub>2</sub> to either setting, S <sub>2</sub> to "b"	Phones to C & D Chassis to A Test probe to B	Touch probe to signal circuits in audio stage. If r.f.-i.f. stages are known to be OK, signals will be heard in phones if preceding parts of audio stage (s) are OK
Signal Tracer (audio)	2	S <sub>1</sub> to "c"	Same as above	Same as above
Signal Tracer (r.f.-i.f.)	2	S <sub>1</sub> to "a"	Phones to C & D Chassis to B Test probe to A	Touch probe to signal circuits in r.f.-i.f. stages. Signals are heard in phones if preceding parts of r.f.-i.f. stages are OK
Speaker Substitute	1	S <sub>1</sub> to "a", S <sub>2</sub> to either setting, S <sub>2</sub> to "a"	Secondary of receiver's output trans. to A & B. Disconnect one end of secondary from receiver's speaker	Substitute speaker will "take over".

# FIX ANY RADIO

## Amazing New Invention



Find radio faults with a new simplified method. Repair all radios in minutes instead of hours. Revolutionary, different Comparison technique permits you to do expert work almost immediately. Most repairs can be made without test equipment. Simplified point-to-point, cross-reference, circuit suggestions locate faults quickly and easily.



### NO TESTERS NEEDED

This newly developed method tells you how to locate the source of trouble in any radio set without equipment. Make needed tests, measure voltage, trace the signal, by using only a 5c resistor, small condenser, and a crystal detector. Inject signals without any signal generator. Test tubes by the new Comparison method. Test tubes without equipment. Repair any radio expertly following simplified picture plans. Improve your radio servicing ability. Data on all sets, portables, FM, AC-DC, P.A., recorders, T.V. Send coupon below.

### CHARTS, BLUE-PRINTS, TESTS

Learn time-saving trouble-shooting short-cuts; find any radio fault with ease. Follow the tests shown on 24 large circuit blue-prints. Gives over 1,000 practical repair hints. For all types of radios. Hundreds of simplified tests using a 5c resistor and any filter condenser. Introductory material to help beginners. Several chapters on test equipment. Complete plan in manual form, 61 job-sheets, data on all tubes, 22 large pages, 8 1/2 x 11 in. Schematics, pictures, charts. Sold on no-risk trial. Price, only \$1.50. Use coupon below.

## New TELEVISION MANUALS

**MOST AMAZING MONEY-SAVING BARGAINS**

The television series manuals are the most remarkable values offered by Supreme Publications in their 17 years of business. These TV manuals at only \$3 and \$2 each are amazing bargains and defy competition. There is nothing else like them. Each manual is a virtual treatise on practical television repairs. By normal standards, each such large manual packed as it is with practical facts, hundreds of illustrations, diagrams, charts, photographs, and expensive extra-large blueprints, should sell for \$10—but as SUPREME special values they are priced at \$3 and \$2 each. Only a publisher who sold over one million TV and radio manuals can offer such bargains based on tremendous volume-sales.

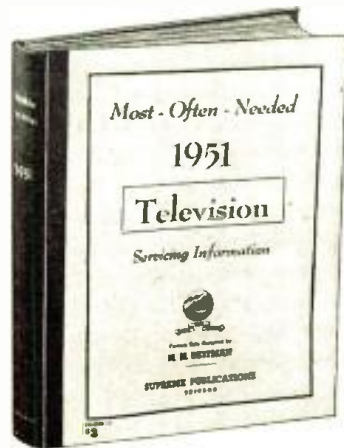

### New 1951 TV Manual

This newest giant volume of the series covers 1951 television factory data. Here is everything you need to repair and adjust all present day TV sets. Covers all popular makes from Admiral to Zenith. There are circuit explanations, 192 pages of alignment procedure, many test patterns, response curves, pages of waveforms, voltage charts, service hints, factory recommended changes, and dozens of double-page diagrams. Manual-style binding, large size: 8 1/2 x 11". Available at your radio jobber or postpaid. See no-risk trial coupon below. Price postpaid, or at your jobber, only ..... **\$3**



Compiled by M. N. Beltman, radio engineer, teacher, author & serviceman.

1950 T-V Manual. Includes service material on all popular TV sets of 1950 period. Large size: 8 1/2 x 11", plus ten mammoth 11 x 15" blueprints. **\$3** Manual-style binding. A bargain at only.....

1949 T-V Manual. Similar to volumes listed above. Has 192 extra-large pages, plus 9 double-spread giant blueprints. To order see coupon below. **\$3** Available also at all jobbers. Only.....

1948 T-V Manual. Earlier volume has material on all popular T-V sets of this period. Large size: 8 1/2 x 11". Remarkable value. Including 8 fold-out blueprints. Servicemen's price only..... **\$3**

1947 FM and T-V Manual. Covers all needed FM and television sets including popular R.C.A. 630TS. Size: 8 1/2 x 11". Data on 192 pages. Flexible covers. Remarkable value at only..... **\$2**

## SUPREME RADIO MANUALS

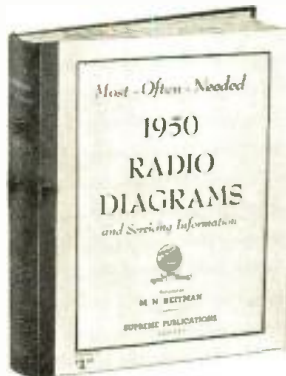

### New 1950 Radio Diagrams

Now you can benefit and save money with Supreme amazing manual scoop. This one giant volume has all the service data you need on all recent radio sets. Here you have clearly-printed large schematics, needed alignment data, parts lists, voltage values, and information on stage gain, location of trimmers, and dial stringing illustrations. This is the help you need to find tough faults in a jiffy. The new 1950 radio manual is a worthy companion to the 9 previous volumes used to an advantage by over 128,000 shrewd radio men.

### BIGGEST BARGAIN IN SERVICE DATA

Wise servicemen know that Supreme Publications manuals have all the material needed at the lowest prices. For the remarkable bargain price (only \$2 for most volumes) you are assured of having on hand needed diagrams and all other essential repair facts on almost all sets you will ever service. Every popular radio of all makes, from old-timers to new 1950 sets is covered. Select manuals wanted, see list below.

### SUPREME RADIO MANUALS for PREVIOUS YEARS



1949 1948 1947 1946 1942 1941 1940 1939 1926-1938  
**SUPREME Most-Often-Needed RADIO DIAGRAMS** **RADIO**  
**Each Manual only \$2. (1949 is \$2.50); 192 pages of diagrams,** **Diagrams**  
**alignment data, voltage values, parts lists, and service** **240 Pages**  
**hints; large size, 8 1/2 x 11". To order, see coupon below.** **Price \$2.50**

### NO-RISK TRIAL ORDER COUPON

**SUPREME PUBLICATIONS, 3727 W. 13 St., Chicago 23, ILL.**

Send the manuals checked below and at right. You guarantee satisfaction or money back.

- Simplified Radio Servicing by Comparison **\$1.50**
- New 1951 Television Service Manual ..... **\$3.**
- 1950 Television Manual, **\$3.**  1949 TV, **\$3.**
- 1948 TV, **\$3.**  1947 TV & FM, only **\$2.**

- I am enclosing \$..... Send postpaid.
- Send C.O.D. I am enclosing \$.... deposit.

Name: .....

Address: .....

#### Most-Often-Needed Radio Diagram Manuals

- New 1950 Manual, **\$2.50**
- 1949 Radio Manual, **\$2.50**
- 1948
- 1947
- 1946
- 1942
- 1941
- 1940
- 1939
- 1926-1938 Manual, **\$2.50**

**PRICED AT ONLY \$2 EACH**

# Supreme Publications

Sold by All Leading Radio Jobbers



Superior's New Model 770

# AN ACCURATE POCKET-SIZE VOLT-OHM MILLIAMMETER

(SENSITIVITY—1000 OHMS PER VOLT)

**FEATURES:** Compact—measures 3 1/8" x 5 7/8" x 2 1/4". Uses latest design 2% accurate 1 Mil. D'Arsonval type meter. Same zero adjustment holds for both resistance ranges. It is not necessary to readjust when switching from one resistance range to another. This is an important time-saving feature never before included in a V.O.M. in this price range. Housed in round-cornered, molded case. Beautiful black etched panel. Depressed letters filled with permanent white, insures long-life even with constant use. **SPECIFICATIONS:** 6 A.C. VOLTAGE RANGES: 0—15/30/150/300/1500/3000 VOLTS. 6 D.C. VOLTAGE RANGES: 0—7.5/15/75/150/750/1500 VOLTS. 4 D.C. CURRENT RANGES: 0—1.5/15/150 MA. 0—1.5 AMPS. 2 RESISTANCE RANGES: 0—500 OHMS 0—1 MEGOHM.

The Model 770 comes complete with self-contained batteries, test leads and all operating instructions.

**\$14<sup>90</sup>**  
NET



Superior's New Model 670

# SUPER-METER

A COMBINATION VOLT-OHM MILLIAMMETER PLUS CAPACITY REACTANCE  
INDUCTANCE AND DECIBEL MEASUREMENTS

**SPECIFICATIONS:**

**D.C. VOLTS:** 0 to 7.5/15/75/150/750/1,500/7,500 Volts  
**A.C. VOLTS:** 0 to 15/30/150/300/1,500/3,000 Volts  
**OUTPUT VOLTS:** 0 to 15/30/150/300/1,500/3,000 Volts  
**D.C. CURRENT:** 0 to 1.5/15/150 Ma. 0 to 1.5 Amperes  
**RESISTANCE:** 0 to 500/100,000 Ohms 0 to 10 Megohms  
**CAPACITY:** .001 to .2 Mfd. .1 to 4 Mfd. (Quality test for electrolytics)  
**REACTANCE:** 700 to 27,000 Ohms 13,000 Ohms to 3 Megohms  
**INDUCTANCE:** 1.75 to 70 Henries 35 to 8,000 Henries  
**DECIBELS:** — 10 to +18 +10 to +38 +30 to +58

**ADDED FEATURE:**

The Model 670 includes a special GOOD-BAD scale for checking the quality of electrolytic condensers at a test potential of 150 Volts.

The Model 670 comes housed in a rugged, crackle-finished steel cabinet complete with test leads and operating instructions. Size 5 1/2" x 7 1/2" x 3".

**\$28<sup>40</sup>**  
NET

Superior's New Model TV-11

# TUBE TESTER



**Specifications**

- Tests all tubes including 4, 5, 6, 7, Octal, Lock-in, Peanut, Bantam, Hearing-aid, Thyatron, Miniatures, Sub-Miniatures, Novals, Sub-Minars, Proximity Fuse Types, etc.
- Tests for "shorts" and "leakages" up to 5 Megohms.
- Uses the new self-cleaning Lever Action Switches for individual element testing. Because all elements are numbered according to pin-number in the RMA base numbering system, the user can instantly identify which element is under test. Tubes having tapped filaments and tubes with filaments terminating in more than one pin are truly tested with the Model TV-11 as any of the pins may be placed in the neutral position when necessary.
- The Model TV-11 does not use any combination type sockets. Instead individual sockets are used for each type of tube. Thus it is impossible to damage a tube by inserting it in the wrong socket.
- Free-moving built-in roll chart provides complete data for all tubes.
- Newly designed Line Voltage Control compensates for variation of any line voltage between 105 Volts and 130 Volts.

**EXTRA SERVICE**

The Model TV-11 may be used as an extremely sensitive Condenser Leakage Checker. A relaxation type oscillator incorporated in this model will detect leakage even when the frequency is one per minute.

**\*NOISE TEST**

Phono Jack on front panel for plugging in either phones or external amplifier will detect microphonic tubes or noise due to faulty elements and loose external connections.

The Model TV-11 operates on 105-130 volt 60 Cycles A.C. Comes housed in a beautiful hand-rubbed oak cabinet complete with portable cover. Size 11 1/2" x 13" x 6". Shpg. wt. 15 lbs.

**\$47<sup>50</sup>**  
NET

----- USE CONVENIENT RUSH ORDER FORM ON OPPOSITE PAGE ----->

**GENERAL ELECTRONIC DISTRIBUTING CO.** DEPT. RN-5, 98 PARK PLACE  
NEW YORK 7, N. Y.

Superior's New Model TV-20



Ultra H. F. Voltmeter Probe converts Model TV-20 into Negative Peak-Reading H. F. Voltmeter.

# 20,000 OHMS PER VOLT MULTI-METER and TELEVISION KILOVOLTMETER

The Model TV-20 was designed to provide all the multi-meter measurement requirements of A. M., F. M. and Television. Unlike other recent models, which are actually standard V.O.M.'s converted to test the new Television Voltages, the Model TV-20 is a completely new unit. It provides the sensitivity, ranges and accessories which are needed to service F. M. and Television in addition to A. M. Radio. The High Voltage Probe for example, with a range of 50,000 volts and designed to withstand 100,000 volts, is an integral part of the instrument with a special compartment for housing it when not in use.

### SPECIFICATIONS

- 9 D. C. VOLTAGE RANGES: (At 20,000 ohms per Volt) 0-2.5/10/50/100/250/500/1,000/5,000/50,000 Volts
- 8 A. C. VOLTAGE RANGES: (At 1,000 ohms per Volt) 0-2.5/10/50/100/250/500/1,000/5,000 Volts
- 5 D. C. CURRENT RANGES: 0-50 Microamperes, 0-5/50/500 Milliampere, 0-5 Amperes
- 4 RESISTANCE RANGES: 0-2,000/20,000 ohms, 0-2/20 Megohms
- 7 D. B. RANGES: (All D. B. ranges based on ODb = Mv. into a 600 ohm line)
  - 4 to + 10 db                      + 22 to + 36 db                      + 36 to + 50 db                      + 48 to + 62 db
  - + 8 to + 22 db                      + 28 to + 42 db                      + 42 to + 56 db
- 7 OUTPUT VOLTAGE RANGES: 0 to 2.5/10/50/100/250/500/1,000 Volts

The Model TV-20 operates on self-contained batteries. Comes housed in beautiful hand-rubbed oak cabinet complete with portable cover, Built-in High Voltage Probe, H. F. Probe, Test Leads and all operating instructions. Measures 4 1/2" x 10 1/4" x 11 1/2". Shipping Weight 10 lbs.

**\$39<sup>95</sup>**  
NET

The New Model 200

# AM and FM SIGNAL GENERATOR



### SPECIFICATIONS

- ★ R.F. FREQUENCY RANGES: 100 Kilocycles to 150 Megacycles.
- ★ MODULATING FREQUENCY: 400 Cycles. May be used for modulating the R.F. signal. Also available separately.
- ★ ATTENUATION: The constant impedance attenuator is isolated from the oscillating circuit by the buffer tube. Output impedance of this model is only 100 ohms. This low impedance reduces losses in the output cable.
- ★ OSCILLATORY CIRCUIT: Hartley oscillator with cathode follower buffer tube. Frequency stability is assured by modulating the buffer tube.
- ★ ACCURACY: Use of high-Q permeability tuned coils adjusted against 1/10th of 1% standards assures an accuracy of 1% on all ranges from 100 Kilocycles to 10 Megacycles and an accuracy of 2% on the higher frequencies.
- ★ TUBES USED: 12AU7—One section is used as oscillator and the second is modulated cathode follower. T-2 is used as modulator. 6C4 is used as rectifier.

The Model 200 operates on 110 Volts A.C. Comes complete with output cable and operating instructions.

**\$21<sup>85</sup>**  
NET

Superior's New Model TV-30

# TELEVISION SIGNAL GENERATOR

ENABLES ALIGNMENT OF TELEVISION I. F. AND FRONT ENDS WITHOUT THE USE OF AN OSCILLOSCOPE!

**FEATURES** Built-in modulator may be used to modulate the R. F. Frequency, also to localize the cause of trouble in the audio circuits of T. V. Receivers.

Double shielding of oscillatory circuit assures stability and reduces radiation to absolute minimum. All I. F. frequencies and 2 to 13 channel frequencies are calibrated direct in Megacycles on the Vernier dial. Markers for the Video and Audio carriers within their respective channels are also calibrated on the dial.

Stability assured by cathode follower buffer tube and double shielding of component parts.

**SPECIFICATIONS** Frequency Range: 4 Bands—No switching: 18-32 Mc., 35-65 Mc., 54-98 Mc., 150-250 Mc.

Audio Modulating Frequency: 400 cycles (Sine Wave). Attenuator: 4 position, ladder type with constant impedance control for fine adjustment.

Model TV-30 comes complete with shielded co-axial lead and all operating instructions. Measure 6" x 7" x 9".

**\$33<sup>95</sup>**  
NET



# MONEY BACK GUARANTEE!!

GENERAL ELECTRONIC DISTRIBUTING CO.

DEPT. RN-5, 98 PARK PLACE, NEW YORK 7, N. Y.

GENTLEMEN: PLEASE RUSH THE MATERIAL LISTED BELOW:

Phone—REctor 2-1677

QUANTITY	MODEL	PRICE	TOTAL

Name \_\_\_\_\_

Address \_\_\_\_\_

City \_\_\_\_\_ Zone \_\_\_\_\_ State \_\_\_\_\_

\$ \_\_\_\_\_ (Payment in Full Enclosed)                      \$ \_\_\_\_\_ (Deposit Enclosed — Ship Balance C.O.D.)



Optical comparator is used to check mica disc specifications to thousandth-inch accuracy.

**ONE  
STANDARD**  
**-The best that can  
be made-for  
Initial Equipment  
and Replacement**



**TUNG-SOL**  
RADIO, TV TUBES, DIAL LAMPS



**TUNG-SOL LAMP WORKS INC.** Newark 4, N. J.  
Sales Offices: Atlanta • Chicago • Dallas • Denver •  
Detroit • Los Angeles • Newark

# Manufacturers' Literature

Readers are asked to write directly to the manufacturer for the literature. By mentioning RADIO & TELEVISION NEWS, the issue and page, and enclosing the proper amount, when indicated, delay will be prevented.

## SYNCHRONOUS GENERATORS

A new 4-page, two-color bulletin describing the company's "Tri-Clad" high speed synchronous generators is currently being offered by *General Electric Company*, Schenectady 5, New York.

The publication, GEA-5470, covers generators for standby, portable, and prime source power in ratings from 1.875 to 50 kva. with frequencies of 60 and 400 cycles. Four designs are described in the bulletin—the externally-regulated, self-regulated, and packaged-regulated 4-pole synchronous generators, and the high frequency 14-pole synchronous generator.

The bulletin lists all of the salient features of the units and provides over-all, cut-away, and exploded views of the generators.

## VEE-D-X CATALOGUE

The *LaPointe-Plascomold Corporation* of Windsor Locks, Conn. has issued its 1951 catalogue which lists the company's complete line of "Vee-D-X" television antennas and accessories.

Along with technical, installation, and ordering data on all antennas, the catalogue contains general information of interest to the trade. Considerable space has been devoted to such products as the company's lightning arrester, a three-way switch box, the new "Mighty-Match," and television towers.

Copies of Catalogue 51 may be obtained by writing the company direct.

## V.T.V.M.'S IN SERVICING

The Radio Tube Division of *Sylvania Electric Products Inc.*, 1740 Broadway, New York 19, New York has issued a new 48-page booklet containing comprehensive information on the use of vacuum tube voltmeters in radio and television servicing.

The booklet is divided into five chapters of concise instructive text describing different types of v.t.v.m.'s, their adjustment, and application in radio receiver tests and measurements, audio amplifier tests and measurements, television receiver tests, and in miscellaneous applications.

Copies of the booklet are being given without charge to dealers purchasing a *Sylvania* TV picture tube through any of the company's authorized distributors between this date and May 31, 1951. After that date copies of the booklet will be available at \$1.00 per copy.

## TECHNICAL DATA

The Amplifilm Division of *Aircraft-Marine Products Inc.*, 1340 N. Fourth

Street, Harrisburg, Pa. has issued a technical data sheet covering its line of "Capitron" high voltage condensers and pulse forming networks.

Since these units employ a new dielectric material, tradenamed "Amplifilm", some of the more pertinent details on this product are also included on the data sheet.

A copy of Bulletin AD-1 is available on request. Persons desiring more complete data on "Amplifilm" should also request a copy of Bulletin AD-2 the "Amplifilm Dielectric Sheet" publication.

## G-E REPLACEMENT PARTS

A new television and radio replacement parts catalogue, listing parts for sets produced from 1945 to December 1, 1950, is currently being sent to distributors by the Receiver Division of *General Electric Company*, Syracuse, New York.

The cloth-covered, 144-page, loose-leaf catalogue features a cross reference between drawing number and part number, making it possible to determine from the drawing alone, all the information about any part. This is a new feature of the catalogue.

Further features include an alphabetical listing by parts number, new and complete part descriptions, set models in which each part is used, list price, and a revision service to keep salesmen up-to-date.

## TV ACCESSORIES

Of interest to television technicians is the new television antenna and accessories catalogue recently published by *JFD Manufacturing Co., Inc.* of 6101 Sixteenth Avenue, Brooklyn 4, New York.

Designated Catalogue No. 58G, the new publication carries a complete listing of the company's line of television antennas, brackets, mounts, screw eyes, lightning arresters, indoor antennas, masts, insulators, transmission lines, guy and ground wire, etc. New listings include data on the company's "Long-Ranger" yagi antenna line.

Copies of the catalogue may be obtained either direct from the company or from the company's distributors.

## TERMINALS AND CONNECTORS

*The Thomas & Betts Co.*, Elizabeth 1, New Jersey has issued a comprehensive catalogue covering pressure terminals and connectors for all types of applications on all wire sizes from #26 through 250 MCM.

Listed in convenient, easy-to-find form, the new "Sta-Kon" Bulletin No. 61 provides a complete list of Armed

**RADIO & TELEVISION NEWS**

# GET YOUR NEW Hallicrafters

COMMUNICATION RECEIVER HERE and

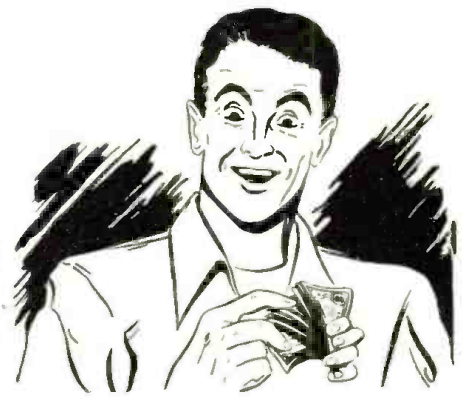

Save Money With a "Surprise" Trade-In Allowance on Your Used Test and Communication Equipment



**HALLICRAFTERS SX-71**  
\$199<sup>50</sup>

Shpg. wt. 33 lbs. .... Only

For the very thriftiest way to buy your new SX-71, trade your used equipment. Profit with a "Surprise" trade in!  
R-46 Spkr. .... Only \$19.95

For super dooper savings on Hallicrafters Receivers get a Walter Ashe "SURPRISE" Trade-In offer on your used (factory-built) Test Instruments or Communication Equipment. Walter will give you an extra-liberal allowance that will put the Hallicrafters model of your choice within easy reach! So don't delay! Get your trade-in deal working today. Wire, write, phone or use the handy coupon below.



**HALLICRAFTERS S-77**

Improved AC-DC version of the famous S-40B—the world's most popular Ham receiver. And with a "Surprise" trade-in you can save plenty. With built-in spkr.

\$99<sup>95</sup>

Shpg. wt. 32 lbs. .... Only



**HALLICRAFTERS S-76**

Apply our liberal "Surprise" trade-in allowance against the above price. What have you got to trade?

\$169<sup>50</sup>

Shpg. wt. 44 lbs. .... Only

R-46 Spkr. .... Only \$19.95

All prices f.o.b. St. Louis  
Phone Chestnut 1125



**Wherever You May Roam . . .**  
Keep The Home Ties With  
The S-72, Long-Range Portable

Soldier, sailor, marine, businessman, diplomat, world traveler, explorer—wherever you are . . . no matter where you go . . . you'll always be just "around the corner" from home with this extra-sensitive, portable broadcast-short wave radio. Plenty of sensitivity for far-distant stations, even where ordinary receiving sets fail. Can be used on 110-120 volt AC or DC or self-contained batteries.

**HALLICRAFTERS S-72** Shpg. wt. 16 lbs. Only \$109<sup>95</sup> (less battery)

**NOVICE AND  
TECHNICIAN LICENSES**

Available July 1st

Get the right start in amateur radio with a "Surprise" Trade-in Allowance, available only at Walter Ashe, headquarters for Hallicrafters Precision Radio—famous throughout the world.

**FREE!**

New 1951 catalog. The "treasure chest" of values in everything in Radio and Electronics.

**Walter Ashe  
RADIO CO.**  
THE HOUSE OF "SURPRISE" TRADE-INS  
1125 PINE ST. • ST. LOUIS 1, MO.

Walter Ashe Radio Co.,  
1125 Pine St., St. Louis 1, Mo. RN-51-5

O. K. Walter, Rush "Surprise" Trade-in offer on my  
.....  
(describe used equipment)

for .....  
(show make and model No. of new equipment desired)

Rush Free Copy of your new 164 page Catalog.

NAME .....

ADDRESS .....

CITY..... Zone..... STATE.....

**SEND  
FOR YOUR  
COPY  
TODAY!**

# insuline *Auto Radio* ANTENNAS and ACCESSORIES

sturdy

hi-quality

"jiffy-installed"

## FENDER and COWL

"Solo-mount"

Patent Applied For

The auto radio antenna "one man" can install in three simple steps!

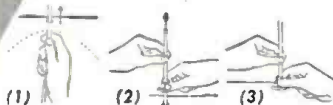

PLACE ADJUST TIGHTEN

... that is all there is to it!

### ALL THE DESIRABLE FEATURES

- Noise-free reception.
- Heavy chrome-plated Admiralty brass.
- Guaranteed rust-proof and rattle-proof.
- Equipped with Delca and Motorola fittings.
- 36" weather-proof, shielded loom cable.
- Three sections — extends to 60 inches.
- Fits all makes of cars, including latest models.

Here is the antenna that is winning wide and enthusiastic acceptance! It embraces every desirable feature that could be packed in any auto antenna... and it takes practically no time to install. That is what your customers want! A labor-saving, time-saving auto radio antenna.



### DISAPPEARING ANTENNAS

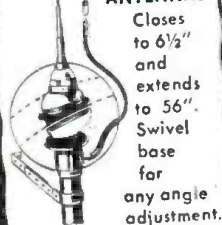

Closes to 6 1/2" and extends to 56". Swivel base for any angle adjustment.

### SIDE COWL ANTENNAS

Varied styles and extension lengths. Complete, ready to install. Fast Seller!

### ANTENNA BOOSTERS

Quickly attached to present aerial. Clever designs.

### ILLUMINATED AUTO ANTENNA

Lights up 24" shaft and discs on top. Fast Seller!

### Do you have our latest catalog?

If not, write Dept. RN-5 at once! Hundreds of items pertaining to auto antennas are fully described and illustrated.

On special request: Catalog of TV antennas and accessories. Catalog of general electronic parts and equipment.

If you plan to attend the PARTS SHOW in Chicago, visit with us at our Booth No. 406.



## insuline CORPORATION OF AMERICA

INSULINE BUILDING • 36-02 35th AVENUE • LONG ISLAND CITY, N. Y.  
West Coast Branch and Warehouse: 1335 South Flower Street, Los Angeles, Calif.  
Exclusive Canadian Sales Agents: CANADIAN MARCONI COMPANY, Toronto

## MAGNA FILTER



## MAGNAFILTER



## MAGNAFILTER'S Top Sales Prove

• CUSTOMERS DEMAND MAGNAFILTER • BIGGER PROFITS FOR YOU!

MAGNAFILTER'S a HIT with TV set owners because it provides easy-on-the-eyes, non-glare, distortion-free enlargement. The image is filtered, enlarged and has a third dimensional effect. MAGNAFILTER combines brilliance with balance... complete full vision.

Made of finest quality materials... selected and fabricated to give ideal contrast in light values and the greatest magnification without distortion. A SURE SELLER — MAGNAFILTER!

Write Today For Literature and Prices

MAGNAFILTER CORPORATION, 11056 Cumpston St., North Hollywood, Calif.

Forces procurement numbers with the corresponding company catalogue numbers. This feature is expected to be of help to those selecting and purchasing fittings for aircraft and naval wiring and for ground force equipment.

The pages carrying specific types of "Sta-Kon" connectors and terminals give complete dimensions in simplified tabular form, along with full information on UL and Armed Forces approvals. Mechanical drawings and information on type of installing tools required are also included.

Requests for copies of Bulletin No. 61 must be made on company letter-head.

### CONDENSED CATALOGUE

Furst Electronics of 12 S. Jefferson Street, Chicago 6, Illinois has just issued a condensed catalogue which carries details on the company's line of regulated power supplies, a new wide-band d.c. amplifier, and a new wow meter.

Information on this equipment is presented in tabular form and each unit is illustrated by a photograph. Nine different models of electronically-regulated power supplies are covered as are the Model 120 d.c. amplifier, the Model 115-R wow meter, and the Model 910 klystron power supply.

Copies of this new catalogue are free on request.

### "TELETOWERS"

A four-page booklet which lists the advantages of "Teletowers" has been issued by Penn Boiler & Burner Mfg. Corp. of Lancaster, Pa.

The colorful brochure points out the special features of this television mast by means of cartoon-type figures and actual photographs.

A copy of the booklet is available without charge from the company.

### NEEDLE DISPLAY CASE

The Accessory Division of Philco Corporation, Philadelphia 34, Pa. has recently released a new phonograph needle display merchandiser which has been designed to help dealers and technicians sell Philco needles.

The new merchandiser, which contains a rear drawer holding 48 individually packaged needles, displays one needle of each type in a tamper-proof, clear-view package on top of the unit. The company's 1951 line includes ruby, sapphire, long-life, and high-quality phonograph needles. Customers can read the advantages of each type of needle below the display package. Although the merchandiser takes up only a few square inches of counter space, it does a big job in helping customers select the proper needles for their individual needs.

### INSTRUMENT DATA

El-Tronics Inc. of 2647-67 N. Howard Street, Philadelphia 33, Pa. is currently offering copies of its Bulletin No. 502 to interested persons.

The new data sheet provides specific-

**RADIO & TELEVISION NEWS**





**FREE** to Radio-TV Service Technicians



**the new fact-packed  
PF INDEX!**

**(PHOTOFACT INDEX AND TECHNICAL DIGEST)**

★ Each issue packed with authoritative articles on TV, Radio, latest servicing techniques

★ Latest complete Index to PHOTOFACT, world's finest service data

Don't miss a single issue! Be sure to get your PF INDEX—the valuable new publication you'll read from cover to cover—and use at your bench every working day.

PF INDEX brings you complete, fully illustrated discussions of latest developments in Radio and TV. Keeps you up-to-date on new circuit designs, latest testing methods, time-saving repair techniques, good shop practices—helps you operate a better, more profitable business.

Have all this practical, authoritative information plus the complete Index to PHOTOFACT Folders—the quick reference guide to the world's finest service data. PF INDEX is worth dollars to you—and costs you nothing. Get your FREE copy today!

**Ask Your Jobber for It!**

**HOWARD W. SAMS & CO., INC.**

Get the current PF Index from your Parts Jobber, or write us direct on your letterhead (or enclose business card). Address: Howard W. Sams & Co., Inc., 2201 E. 46th St., Indianapolis 5, Ind.

**FREE**

Send FREE copy of the current PF Index

Name.....

Address.....

City.....State.....

cations on two of the company's latest test instruments, the Model SG5 square wave generator and the Model MO5 insulation resistance tester.

The square wave generator which is designed for the high speed testing of response characteristics of wide-band amplifiers, wideband oscilloscopes, television video amplifiers, etc., has five fixed output frequencies of 50, 1000, 10,000, 100,000, and 500,000 PPS.

The Model MO5 is a compact, portable, battery-operated insulation resistance tester which operates entirely from two self-contained 1½ volt batteries.

For copies of this data sheet write direct to the company specifying Bulletin No. 502.

**CIVIL DEFENSE RECEIVER**

The Advertising Distribution Section of the *General Electric* Electronics Department, Electronics Park, Syracuse, New York is currently offering copies of a new catalogue sheet which describes the company's new civil defense receiver in some detail.

Designed for application wherever two-way radio systems exist, the new

unit is available in two models for low and high band operation.

The new data sheet provides complete specifications and features on the receiver.

The receiver can be used to alert key agencies and personnel in a community-wide civil defense radio communications system and for remotely controlling air raid sirens and other warning devices.

**ROBOT CONTROLS**

Free literature covering modern operating equipment for doors and gates is being offered to interested persons by *Robot Appliances, Inc.* of 13165 Prospect Avenue, Dearborn, Michigan.

This comprehensive bulletin includes a simple description of such devices along with a liberal use of explanatory diagrams and photographs.

The bulletin describes in some detail the most important applications of such devices both in the home and in commercial establishments, factories, warehouses, and public institutions.

Copies of this bulletin will be forwarded, on request.

-30-

**Voice Controlled Unit**

*(Continued from page 57)*

we get the transmitter on, the receiver off, and the antenna switched with one control or *vice versa* on reception.

Just a word of warning. Condenser C<sub>6</sub> must be a paper type as an electrolytic has too much leakage for this application. The power supply for this gadget is not shown on the diagram since any conventional layout which gives 250 volts d.c. at 70 ma. can be used.

In the front view of the unit the power transformer, rectifier tube, filter condenser, and relay are shown at the left of the chassis. The 2050 tube is in the center and the 6SJ7 and 6J5 are to the right of the chassis with

the 6H6 located between them and the 2050. The two binding posts for the control circuit are to the left on the front apron with the delay control next and the input connector to the extreme right. Connections are made through an *Amphenol* "Y" connector (not shown in the photograph) one side of which connects to the mike and the other side to the speech amplifier in the transmitter. If desired, two chassis connectors could be used instead. They should be wired in parallel with special attention being given to adequate shielding.

In the underchassis view of the unit, the filter choke is mounted at the rear of the chassis while the audio transformer is towards the front. There is an unused socket in the center of the chassis which is used mainly as a tie point for various leads.

-30-

Under chassis view of the unit. See text for identification of components.

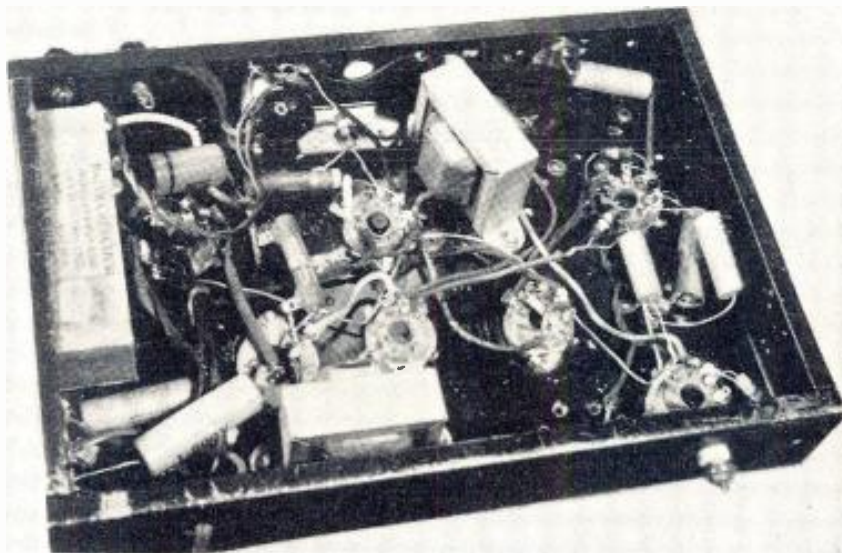

**Mae's Service Shop**  
(Continued from page 66)

to keep the crystal, when not in use, in some kind of a desiccator. A capped fruit jar about half-filled with calcium chloride or silica gel and having a wire screen platform fastened above the level of the desiccant makes such a device. The cartridge is simply placed on the wire screen when not in use, and the moisture is removed from it and kept out of it by the action of the chemical beneath."

"Looks like we need a cartridge not affected by tropical heat and humidity," Barney observed.

"We've got them. The ceramic and PN types of cartridges are both capable of withstanding high temperatures. The PN cartridge will temporarily take temperatures as high as 212 degrees without permanent injury. Then, too, there are the variable reluctance cartridges. Unfortunately, each of these has one drawback or another, such as low output voltage, non-linear response, restricted range, or high cost that prevents any one from being the perfect substitute for the old reliable Rochelle salt cartridge."

"I'm a little hazy on just how crystal cartridges are made," Barney confessed. "I intend to save up a bunch of old ones and take them apart some day when business is slack."

"There's no need to do that," Mac said. "I have reprints of several articles that have appeared in technical magazines which give isometric drawings, cross-section views, assembly pictures, etc., of both conventional and lever-type crystal cartridges. These illustrations and the accompanying text will give you a very clear idea of how cartridges are put together and how they work."

"That ought to be enough 'canned' information to hold me for a while," Barney said. "I'll read the stuff tonight. Now have you got any information that you have picked up from your own experience?"

"You probably have most of that already," Mac said. "I have showed you how you can often detect a cracked crystal by applying a slight lateral pressure to the tone arm while it is playing a record. This pressure holds the broken edges firmly together and makes the output sound fairly good until the pressure is released. You have also heard me tell customers time and again to hold *the needle*, rather than the tone arm, with the fingers of the left hand while the needle-holding screw is tightened with the right. This prevents the excessive torque applied to the screw from being transmitted to the crystal itself.

"You also know how insistent I am on using an exact duplicate replacement cartridge when at all possible; and, when this cannot be done, we try to match the needle-pressure, voltage output, and frequency range of the substitute crystal as nearly as possible



Over 250,000 installed in 1950



the WORKSHOP **DUBL-VEE** TV ANTENNA

U.S. PATENT NO. 2-538-915

For top, high-quality, all-channel reception you can't do better than install the Workshop DUBL-VEE antenna. Its high-gain, "end-fire" circuit is now protected by a basic electrical patent . . . rare among TV antennas. Streamlined but rugged, because of extremely low wind resistance, its appearance is clean-cut and inconspicuous on a roof top. Ghosts and snow are reduced to the barest minimum even in the toughest locations, and performance is boosted on the difficult high channels 7 to 13. For brilliant, outstanding pictures on all channels, specify the Workshop DUBL-VEE.

**WRITE FOR** new folder describing the DUBL-VEE and how to pick the model best suited to your location.

**THE WORKSHOP ASSOCIATES**  
INCORPORATED

*Specialists in High Frequency Antennas*

135 Crescent Road, Needham Heights 94, Massachusetts



The NEW  
Leader!

# CLEAR BEAM T-MATCH YAGI



This powerful, all-weather T-Match Yagi with its mighty 5-element beam, perfect 300-ohm match, rugged dural aluminum construction and other exclusive design features, assures ultra-high gain reception in any area, any climate. Choose Clear Beam for complete customer satisfaction now and for the years ahead!

*all weather*  
**5-ELEMENT ARRAY**  
**300-OHM MATCH**  
**LOW IN COST**  
**60-Second Snap-Open Assembly**  
Simply snap open ... and tighten!

A COMPLETE LINE OF QUALITY ANTENNAS TO MEET EVERY TV RECEPTION REQUIREMENT

## Clear Beam Antennas

618 N. LaBrea Ave., Los Angeles 36, Calif., YOrk 1682

HARRISON HAS IT!

# ONCE-IN-A-LIFETIME TV BOOSTER BARGAIN!



Regular Net Price ~~\$39.95~~

Makes clear, bright pictures possible in fringe areas and in difficult installations where outdoor antennas are not possible. Greatly reduces noise and other interference. Look at the amazing features offered by this famous NATIONAL TV Booster -

- Uniform gain on all 12 channels!
- Excellent signal-to-noise ratio!
- Separate, high-gain 6AK5 RF stage for high and low bands!
- Inputs of 300 ohms and 72 ohms to match any type antenna!
- AC receptacle for TV set, permits turning receiver on or off together with the booster.
- Attractive Red-Glo pilot indicator reminds when booster is on!
- Beautiful walnut finish, plastic cabinet harmonizes with any TV receiver.
- Simple to install and operate - fine tuning control assures best possible definition!
- Electrostatic Shielding!
- Self-contained power supply for 110 Volts, 60 Cycles AC.

Send for free descriptive literature.

### FREE MONEY?

Well, almost! Save \$1.00 on each of your next four radio parts or equipment orders! Send only \$1.50 for our mammoth, 1200-page Radio's Master Buyers Guide\* (Describes and illustrates products of every leading electronics manufacturer) PLUS four credit slips, each worth \$1.00 on any order totaling \$5.00 or more. Your money back if you can't agree that this is the biggest value in radio history! \*Priced by Publisher at \$5.50



Thousands sold at the regular net price of \$39.95—HARRISON brings you this precision-engineered NATIONAL booster at less than wholesale cost!!

## Only \$15.95

COMPLETE WITH TUBES  
(Shipping weight 5 pounds)

Original factory sealed cartons — fully guaranteed!

Rush your order today for immediate delivery. Supply is limited! When these are gone, no more will be available at this special price. Hurry!



HARRISON RADIO CORPORATION

225 GREENWICH STREET • NEW YORK 7, N. Y.  
BARclay 7-7777

to the characteristics of the original. Just because a cartridge will fit mechanically is certainly no sign it is a satisfactory replacement.

"You have also noticed that I often sell and install a complete tone-arm when one of the old-fashioned crystal cartridges goes bad in a really good player. I do this to give the customer the advantages of new type cartridges, which include greatly reduced record wear because of lighter needle pressures and also extended tone range. Putting such a cartridge in one of those heavy old tone arms is no good. Of course, in the cheaper record players, such as those designed for playing children's records, this added expense is not warranted."

"I remember vividly," Barney said with a reminiscent grin, "that we never solder leads to cartridge pin-jacks with the jacks in place on the pins. I quote: 'Those jacks are used just to keep the heat of the soldering iron away from the crystal element!'"

"Well, I wanted to make that emphatic," Mac said with an answering grin. "And another point that is equally important is never to move a record player without first seeing to it that the tone arm is firmly fastened with Scotch tape or some other similar means so that it cannot flail around inside the cabinet while on the way to or from the shop. Many a cartridge has been taken for a last ride because this item was overlooked."

### Converting the Model 811

(Continued from page 41)

reconnect it to terminal #8 of the sweep transformer. Make sure the leads from the horizontal size coil do not short to the frame of the sweep transformer. Connections from terminals #4 and #8 of the sweep transformer should be made with high voltage insulation wire. Short out the series coil in the size control by shunting resistor  $R_{10}$  with a jumper wire. Terminal #5 on the transformer is not used.

Now remove the 4700 ohm resistor,  $R_{10}$ , from across the horizontal linearity control,  $L_{10}$ .

Connect the new deflection yoke and focus coil into the circuit using the old components as a wiring guide.

Assemble and connect the 16KP4 picture tube to the chassis and turn the receiver on. Adjust the focus coil and ion trap for brightness and the width, horizontal linearity, height and vertical linearity controls for the most linear test pattern.

The height can be corrected by connecting a resistance box across the 2.2 megohm resistor,  $R_{30}$ , which is connected between pin #5 of the 6SN7GT vertical sweep generator ( $V_3$ ) and the vertical size control. The resistance should then be varied, together with the vertical size and height controls, until a linear pattern is obtained. Either the shunt resistance or total resistance can be measured with an

RADIO & TELEVISION NEWS

**932 PHOTO TUBE**

Gas Photo-tube having 51 response, particularly sensitive to Red and Near Infrared Radiation. Can be used with incandescent light source. Send for Data. Price..... **75c**

**ARC 5 MOOU-LATOR**  
M17 ARC's Plate Modulator w/ dynamotor complete w/ Tubes 1-1215, 2-1215, 1-VR500, cond. cond. Price..... **\$6.95**  
BC-450 Screen Mod..... **\$2.25**

**EE89A TELEPHONE REPEATER**  
Used to extend range of field telephones, tele. & 20 eye. Fine-tuning possible over time. Includes w/21QEC tube & phone. Feather-weight. Price **\$9.95**

**400 MA 12 HY Choke**  
30 ohms H e r m. sealed. Special..... **\$3.75**

**Helman Ckt Bks for AC-DC operation.**  
AM 151M 7 Amp  
1614 80 Amp  
1614 50 Amp  
Price each..... **\$1.10**

**PHOTO EQUIP.**

Photo Material High-Speed (Kodak) Approx. 1 Qt. Bot. \$3.95  
Photo Unit Surface Cleaning Solution Photomat 11thmat Appx. 1 Qt. \$3.95  
Transparacu 2 140 For Transparacuizing Drawings & Tracing. Appx. 1 Qt..... **\$6.95**

**AMPLIFIER**  
AM-32/PHS1 less batt w/carry case for Mine Detector AN/PHS1 w/tubes. Price ea..... **\$5.95**

**Bitcher Tube Clamps**  
M a n y s in stock. Phone or write spec. Each..... **16c**  
10..... **1.50**  
100..... **\$14.00**

**RE/ADP7 Compass Rev A1N7 Rec Unit**  
150 K c in 4 bands 5 gank Tuning Capacitor w/15 Tubes. Phone for price.

**Fish Pole or Sectional Antennas**

M549-52, 12 1/2 ft. ....	\$1.69
M549-53, 16 ft. ....	2.49
M549-54, 25 ft. ....	3.98
BASES: MP22.....	3.95

Mfd.	Volt.	Price
5	50	\$0.45
650	80	1.95
5	150 AC	1.45
15	220 AC	2.20
1	500	.40
7	600	1.25
20	600	2.10
0.5	750 AC	1.59
0.5	1000	.69
2x0.5	1000	.70
1	1000	.75
1.5	1000	.85
2	1000	.90
4	1000	1.75
1200	1200	1.35
1500	1500	1.25
0.0010	1500	1.30
0.1	1500	1.40
1.5	1500	1.45
2	2000	1.45
2	2000	2.25
2	2200	2.45
0.5	2500	1.35
1.5	2500	1.35
0.15	4000	1.20
2x0.1	4000	1.20
0.1	6000	1.20
2x0.1	7000	1.25
0.1	7500	1.25
2x0.15	8000	4.75

**MANY OTHERS**  
6V Input  
Output 150V or 12V  
Input 500V out.  
\$3.49

Avail. in Stock. Dual **XMTTR** & Dual Rec. Triple Rack Mounts  
MTG3 - MTG5 - MT71. Banded  
P. o r s o l d a s i s. No Refund.  
Repairable..... **\$1.00**

**274N (ARCS) XMTRRS VFO DRIVERS 40 WATT OUTPUT**



4-5.3MC \$5.95  
5.3-7MC \$5.95  
7-9.1MC \$3.95

Cond. w/Tube & XTAL.  
BC 604 FM Transmitter P. M. 20-28 MC 11 & 15 Mtr. Can be operated on 10 M Tr. 10 Channel push button control tubes meter. Less 2 A R. Good used. Includes Dynamotor. Set of 80 xtal. **\$25.00**

BC433 Mod or unmod. CV Re-duction 300-17.0KC to 3 bands 14 & 24V & 115V AC ADP. Radio Compass An Is. Less 2 Tubes. P o r s o l d a s i s. No Refund. Repairable..... **\$1.00**

**RL 9 or RL 7**

In telephone Amplifier Convert to High Fidelity Phone Amp. or S. p. h. Amp. Compl. 3 A 6 S. 12S1-7. 2 Chokes. 1XFRMR. DYN for 24v. operation, etc. **\$2.29**

**BC-746 TUNING UNIT**  
Plug-in transmitter tuning unit from Army Walkie-Talkie. Contains antenna and tank coils, tuning condenser, transmitting and receiving crystals. Ideal transmitter foundation. Price..... **\$1.29**

**GIBSON GIRL**  
The Emergency Radio Transmitter. Set of 8 S signals automatically on 500KC. 150-mile range. No batteries required. Has hand-driven generator tubes, wiring. New. It's only..... **\$4.29**

**1% PRECISION RESISTORS**

1.01	128	10.000
1.01	250	12.000
1.01	500	12.000
5.05	430	17.000
10.1	463	17.000
18	800	25.000
43.5	920	25.000
50	1100	30.000
75	1800	57.000
82	5000	40.000
120	7500	55.000
125	8500	57.000
128	10,000	75.000
150	10,000	84.000
30c ea. 10 for \$2.50		
100.000		150.000
120.000		220K
120.000		\$7.000
40c ea. 10 for \$3.50		
1 Meg. 75c ea.		

**CRYSTALS Low Freq.**

FT241-A. Halder 1/2" Pin spacing, for ham and general use. Xtal controlled. Signal Generators. Me harmonic crystals. Army Harmonics—Distinctions for deriving fundamental frequencies enclosed. Listed below by fundamental frequency, fractions omitted.

370	396	420	446	487	514	447
372	397	422	458	488	515	448
374	398	423	459	490	516	450
375	400	424	461	491	518	451
376	401	425	462	492	519	453
377	402	427	468	493	520	454
379	403	429	469	494	522	455
380	404	430	470	495	523	456
381	405	431	472	496	525	457
383	406	433	473	497	526	463
384	407	434	474	502	527	465
385	408	435	475	503	529	498
386	409	436	476	504	530	500
387	411	437	477	505	531	501
388	412	438	479	506	533	538
390	413	440	480	507	534	540
391	414	441	481	508	536	
392	415	442	483	509	537	each
393	416	443	484	510	538	each
394	418	444	485	512		
395	419	445	486	513		

**69c \$1.49**

**WESTERN ELECTRIC PRECISION RESISTORS 1%**

D-164886A	2.65 ohms
D-164886A	3.83 ohms
D-167026	13,500/15,000 ohms
D-162025AT	1400/135 270 ohms
D-164285	40,000/15,000 ohms
D-162850FL	1155 ohms
D-162747V	270 ohms
D-171822	270 ohms
D-171863	291 ohms
D-164286	10,000/15,000/62,000 ohms
D-164284	100,000 50,000 ohms
D-172241	400/600/700/750 ohms

**@ 75c ea.**

**ARC 5 EQUIPMENT**

PA Coils No. 7247..... **79c**  
Parabolic Suppressors..... **5c**  
1 Kit of 3, 2830 KC IFA, consisting of input, intermediate, and output for 6-B Rec..... **\$1.25**  
BC 604 FM Transmitter..... **4.9c**  
BFO Rec 2830 KC for 6-B MC No. 58550..... **4.9c**  
1415 KC for 3-B MC No. 5855..... **4.9c**  
Radio Compass..... **1.0c**  
Cond. 05-01-05 300V 5415..... **1.0c**  
XFRMR Mike to Grid No. 6201..... **79c**  
Meter Dial Comp. 6029, 6030, 6032..... **79c ea.**  
Plug 6 Pin for IF..... **10c ea.**  
Plug 7 Pin for Rec. Chassis..... **10c**  
Plug 8 Pin for Rec. DYN. Male and Female..... **15c ea.**  
Plug 3 Pin for Mod. Dyn. Male..... **29c**  
Plug 5 Pin Chassis Int..... **29c**  
Plug No. 5842 Rear Rec. XMTR Male..... **29c**  
Plug No. 6177 6 Pin Rec..... **29c**  
Plug No. 6118 8 Pin Rec. Back..... **29c**  
Plug No. 7127 18 Pin Mod. Chassis..... **29c**  
PL 15A 12 PNC Male..... **49c**  
PL 15A 18 PNC Male..... **49c**  
PL 148 3 PNC Male..... **49c**  
PL 150A 3 PNC Male..... **49c**  
Plug No. 2674 Chassis High Freq. Rack. 2 PNC..... **29c**  
Plate 190-530 Cont. Base..... **10c**  
Richard Ward Cont. Base..... **10c**  
Load Coils No. 6035, 6034, 7992..... **59c ea.**  
Fuse Mntn., Dual..... **12c ea.**  
Crystals 1620-1629-1625..... **\$1.00 ea.**  
WRITE for Other Equipment.

**SELSYN TESTER**

Magnesium Instrument Field Tester AAF 42G2333a Spec. 40772. To test individual mag. Incl. Xmitters, for Isolating Faults in magnesia system. Brand new..... **\$9.00**

**LEARN OR TEACH CODE**  
Uses 6-10-24-11 1.5 V  
Dt. 115-230 VAC. Can use hookup of over 20 students. Contains speaker, blinker, freq. control, etc. in fiber trunk 17"x17"x10 1/2".  
Now..... **\$24.95**

**VARIABLE TRIMMER CONDENSERS**  
C890 15 MMF  
C881 20 MMF  
C993 50 MMF  
C677 60 MMF } **32c ea.**

**VITREOUS RESISTOR AND OTHERS**

Ohms	Size	Type	Price
5M	2x 3/4 D	Lugs	20c
12	2 1/2 1/4 D	Lugs	18c
2500	2 1/2 3/4	Lugs Var.	20c
5M	2 1/2 3/4	Lugs	20c
100	1 1/2 3/4	Lugs	15c
3150	2 1/2 3/4	Lugs	20c
1000	2 1/2 3/4	Lugs	20c
500	4 1/2 x 3/4	Lugs	30c
7500	4 1/2 x 3/4	Lugs	30c
10	2 1/2 x 3/4	Lugs	35c
3000	3 1/2 x 3/4	Lugs	25c
12000	3 1/2 x 3/4	Lugs	25c
10	6 1/2 x 1 1/2	Lugs	45c
5C7	6 1/2 x 1 1/2	Lugs	40c
5000	2 1/2 x 3/4	Lugs	20c

**BATH TUB CAPACITORS**

MFD	VOLT.	TYPE	PRICE EACH 10 FOR	
5	400	2BT	\$0.23 \$2.20	
5	600	2TT	.25 2.40	
3X.1	600	3TT	.45 4.35	
3X.1	600	3ST	.45 4.35	
2X.1	600	3ST	.26 2.50	
2X.1	600	3BT	.28 2.65	
2X.1	600	3BT	.28 2.65	
2X.1	600	2TT	.26 2.50	
2X.1	200	2ST	.23 2.20	
2X.1	600	2ST	.26 2.50	
2X.1	600	3TT	.26 2.50	
1-1-1	400	3ST	.28 2.65	
.025	1	600	2BT	.22 2.10
	1	600	1ST	.22 2.10
	1	600	2TT	.22 2.10
	1	600	2ST	.22 2.10
	13	600	2ST	.25 2.40
	2X.25	600	3ST	.30 2.85
	.05	600	2TT	.21 2.00
	1	100	2TT	.23 2.20
	20	50	2ST	.26 2.50

**MICA CAPACITORS SOLAR XMB TAPPED POLES**

Mfd.	Price
2500 V Test	
.00001	\$0.29
.000025	.29
.00003	.29
.00005	.29
.000075	.29
.0001	.29
.00015	.29
.00025	.29
.0003	.29
.0004	.29
.0005	.35
.00075	.35
.00085	.35
.001	.35
.0015	.35
.0015	.35
.0017	.35
.002	.35
.0023	.35
.003	.45
.004	.45
.005	.45
.006	.45
.007	.45
.008	.45
.009	.45
.01	.45
.015	.45
.02	.45
.025	.45
.03	.45
.04	.45
.05	.45
.06	.45
.07	.45
.08	.45
.09	.45
.1	.45
.15	.45
.2	.45
.25	.45
.3	.45
.4	.45
.5	.45
.75	.45
1	.45
1.5	.45
2	.45
2.5	.45
3	.45
4	.45
5	.45
6	.45
7	.45
8	.45
9	.45
10	.45
15	.45
20	.45
25	.45
30	.45
35	.45
40	.45
45	.45
50	.45
60	.45
70	.45
80	.45
90	.45
100	.45
150	.45
200	.45
250	.45
300	.45
350	.45
400	.45
450	.45
500	.45
600	.45
700	.45
800	.45
900	.45
1000	.45

**Solar XQ Solder Lugs 2500 V Test**

Mfd.	Price
.01	.85
.015	.85
.02	.85
.03	.85
.04	.85
.05	.85
.06	.85
.07	.85
.08	.85
.09	.85
.1	.85
.15	.85
.2	.85
.25	.85
.3	.85
.4	.85
.5	.85
.75	.85
1	.85
1.5	.85
2	.85
2.5	.85
3	.85
4	.85
5	.85
6	.85
7	.85
8	.85
9	.85
10	.85
15	.85
20	.85
25	.85
30	.85
35	.85
40	.85
45	.85
50	.85
60	.85
70	.85
80	.85
90	.85
100	.85
150	.85
200	.85
250	.85
300	.85
350	.85
400	.85
450	.85
500	.85
600	.85
700	.85
800	.85
900	.85
1000	.85

**Solar XQ Solder Lugs 2500 V Test**

Mfd.	Price
.01	.85
.015	.85
.02	.85
.03	.85
.04	.85
.05	.85
.06	.85
.07	.85
.08	.85
.09	.85
.1	.85
.15	.85
.2	.85
.25	.85
.3	.85
.4	.85
.5	.85
.75	.85
1	.85
1.5	.85
2	.85
2.5	.85
3	.85
4	.85
5	.85
6	.85
7	.85
8	.85
9	.85
10	.85
15	.85
20	.85
25	.85
30	.85
35	.85
40	.85
45	.85
50	.85
60	.85
70	.85
80	.85
90	.85
100	.85
15	

# TRANSVISION

ANNOUNCES

## NEW LOW PRICES

on 17"-20" TV KITS,  
CHASSIS and CABINETS

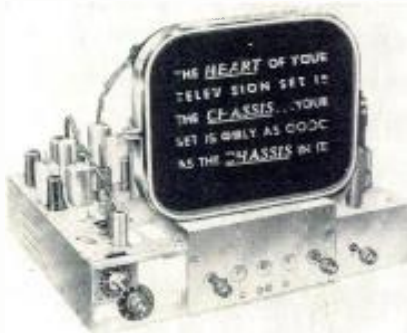

**SAVE UP TO 50%!**

Transvision makes the **fastest TV KITS** and **WIRED CHASSIS** that money can buy. **PRICED AMAZINGLY LOW.** Kits are easy to assemble. Give top quality picture and sound. Ideal for both hobbyists and dealers.

**BEAUTIFUL NEW CABINETS.**

Write for Catalog RN.



Write for Prices and Details Today!

**TRANSVISION, INC.**

Dept. RN NEW ROCHELLE, N. Y.

ohmmeter and the required change made. It was found necessary to reduce the value of this resistor to 1.3 megohms in this particular receiver, however, this resistance may vary somewhat in different receivers.

### Cabinet Changes

To adapt the cabinet of the Model 811 to accommodate the 12 inch tube first remove the mask and safety glass assembly which is held in by several wood screws accessible from the inside of the cabinet. If a 12LP4A picture tube is to be used, the wooden panel in back of the safety glass can be angled cut with a jig saw to make a 12 inch "expanded" mask. A template can be made according to the dimensions given in Fig. 3. This should be centered on the panel as the original opening was above center. The angle cut should be approximately the same as the original mask. The four angle brackets can be relocated so that the springs on the "grounding" ring will hold the 12LP4A in place. The front of this panel should be painted with a paint similar to that originally used. It was found that "Sunlit Green" in the Dutch Boy "Wonsover" brand paint was a very close match.

The brown paint backing between the mask opening and the inside bronze border on the safety glass must be removed. A razor blade or some other sharp instrument can be used for this purpose. The wooden block which holds the deflection yoke will have to be moved about one and a half inches toward the back of the cabinet. This is held by two wood screws and glue and can be removed by using a wood chisel to loosen the edges and then tapping with a hammer after the screws are removed. The complete receiver can now be reassembled and the twelve inch conversion is completed.

### Sixteen-Inch Cabinet Changes

In making the necessary cabinet changes the safety glass and wooden panel were removed and discarded. Due to the slight difference between the 16KP4 and the 17BP4A faceplate, as shown in Fig. 4, either type tube or mask can be used. A 16 inch mask measuring 13½"x17" outside diameter was used. This mask filled the vertical opening completely and came within ¼" on each side. The mask used was manufactured by the Tele-Plastics Co. and can be obtained through local radio parts distributors. The name of a distributor in your locality can be obtained by writing the Tele-Plastics Co., Division of Willmax Mfg. Co., 177 South 8th Street, Brooklyn 11, New York.

Two pieces of wood, 13"x1"x¾" were cut to fill the side openings and hold the mask in place. These pieces were sanded and stained a dark walnut. Two ½" holes were drilled through the side of each piece about two inches from the top and bottom and mounted to each side of the cabinet in back of the mask, using 1¼" wood screws. Two 2" angles were fas-

## Master Mobile

ANTENNAS MOUNTS

For any car or truck—SINGLE and TWO-WAY work—Civilian Air Patrol, Fire, Police, Amateur, Telephone, Ambulance, Farm, etc. **STURDY, QUALITY-BUILT** with **TOP RECEPTION and SENDING** assured. Finest materials and construction. Hammetone, or Chrome finish antennas (if available).

### MASTER "ALL-BAND" MOBILE ANTENNA

Approved CENTER-LOADED COIL DESIGN. Interchangeable LOADING COIL for 20, 40, 75 meters. Short out coil for 10 meter operation. 8¼" high. Wt., 28 oz. Fits any MASTER MOUNT or ¾" SAE thread. Heavy Duty Mounts (X Series) recommended. COILS—1/2" SAE, one coil, less spring mount—\$8.75. Specially meter coil wanted. EXTRA COILS—only \$3.30.



126 132 138 142 140 92 106 100

### MASTER MOBILE MOUNTS

Model	Description	Net Price
126	—Straight Spring—Swivel Base	\$ 8.75
126X	—Heavy Duty—Straight Spring—Swivel Base	9.40
132	—Double Tapered—Spring Swivel Base	8.75
132X	—Heavy Duty—Double Tapered	9.85
132S	—Stainless Steel—Double Tapered	10.75
132, 132X, 132S	—SPRING SWIVEL BASE	
132XS	—Hvy. Duty Stainless Steel—Dble. Taper.	11.85
138	—Straight Spring	6.55
138X	—Heavy Duty—Straight Spring	7.65
140	—Double Tapered Spring	6.55
140X	—Heavy Duty—Double Tapered Spring	7.65
140S	—Stainless Steel—Double Tapered Spring	8.65
140XS	—Heavy Duty Stainless Steel—Double Tapered Spring	9.65
142	—Less Spring, with insulators for Direct Mounting by Series 100 Antennas or 92 Extension and 106 Antennas	3.25

### MASTER MOBILE WHIP ANTENNAS

No. 100—Threaded ¾" stud—to fit all MASTER Mounts.  
Type 100—Plain end—¾" dia. Fits No. 92—18" antenna extension.

Model	Net Each	Length	Model	Net Each
100-60S	\$4.95	60"	106-60S	\$4.15
100-72S	4.95	72"	106-72S	4.15
100-78S	5.00	78"	106-78S	4.20
100-86S	5.15	86"	106-86S	4.35
100-90S	5.20	90"	106-90S	4.40
100-96S	5.25	96"	106-96S	4.50

No. 92 Extension—18".....only \$3.25  
No. 94 Extension—36".....only \$4.25  
(Both provide for adjustment of length of Series 106 Antennas.)

SPRINGS Only—For Antenna Mounts—Straight or Double Taper—with studs both ends:  
No. 100—Regular.....\$4.50  
No. 100X—Heavy Duty.....\$5.50

**ORDER FROM YOUR DEALER OR JOBBER**

**MASTER MOBILE MOUNTS, Inc.**

P. O. Box 1817 Los Angeles 36, Calif.

## RADIO and TELEVISION

Thorough training for men and women in all Technical phases **APPROVED FOR VETERANS WEEKLY RATES DAYS—EVENINGS FREE PLACEMENT SERVICE FOR GRADUATES**

For Free Catalog write Dept. RN-51  
**RCA INSTITUTES, INC.**  
A Service of Radio Corporation of America  
350 West 4th St., New York 14, N. Y.

## MARK THESE VALUES!

**6SN7GT. \$1.08** RCA • Sylvania • N-U  
5U4G...95c 6AL5...89c TunoSol • KenRad  
6AU6...98c 12AU7...\$1.19 Hytron • G-E • Raytheon  
Free List 25% Deposit. Balance C.O.D. F.O.B. New York

SELL YOUR SURPLUS TUBES • TOP PRICES

**MARK electronics** 220 Fifth Ave. NEW YORK, N. Y.

**RADIO & TELEVISION NEWS**

tened to the cabinet below the picture tube. A piece of 1/2" rubber cushion was attached to the top surface which provided a "shock" mount and held the picture tube in the correct horizontal position. The "grounding" ring was used to hold the tube to the cabinet by using only two of the four springs. The mounting block for the deflection yoke assembly was moved back about one and one-half inches as described in the 12" conversion. The completed receiver was reassembled and appears as shown in Fig. 2.

Just one word of caution to technicians who decided to undertake conversion work. Always check the complete receiver to make sure it is operating satisfactorily before disassembling. The reasons for this are obvious and it may save call-backs and considerable time when checking the receiver after the conversion has been made. The instructions included herewith are intended to convert the set, not correct circuit faults existing in the set before conversion!

-30-

### ATLANTA HAMFEST

THE 1951 Annual Hamfest of the Atlanta Radio Club has been scheduled for Sunday, June 10th at Robinson's Tropical Gardens in Atlanta.

An elaborate program featuring entertainment for every member of the family has been planned. Dinner will be served buffet style with seating for 800 being guaranteed.

Tickets for the affair are \$2.50 for adults, \$1.75 for children between 4 and 12 with children under 4 admitted free. A drawing for door prizes will be held.

Complete details on the Hamfest and tickets are available from Lee Connell, W4N00, secretary of the club, 624 Page Avenue, N.E., Atlanta, Georgia.

-30-

### AVOID TUBE DAMAGE

By H. LEEPER

RUBBER tube pullers are available for miniature and other tubes located in confined places.

When using a soldering iron or other tools near one of these tubes, why not cover it with a tube puller as shown?

The tube tip or glass envelope may be saved from damage by so doing.

-30-

Use tube puller as a soldering shield.



Reach out **FARTHER...**  
and bring 'em in **STRONGER!**



"Long Ranger"

# YAGI TV ANTENNA ARRAYS

with High Impedance Driven Element for  
Direct Match to 300 Ohm Lead-in.

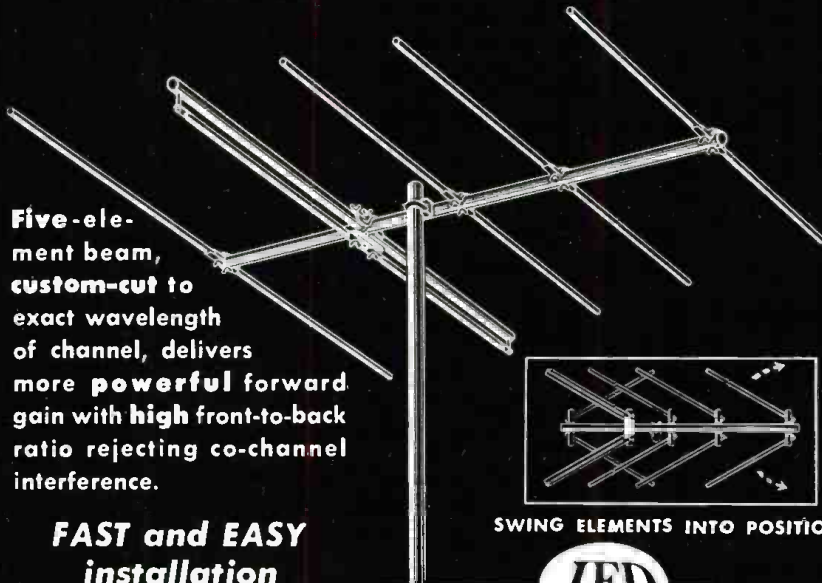

Five-element beam, custom-cut to exact wavelength of channel, delivers more powerful forward gain with high front-to-back ratio rejecting co-channel interference.

SWING ELEMENTS INTO POSITION



### 5-ELEMENT YAGIS

#### LOW BAND

No. 5Y2 (Channel 2)  
No. 5Y3 (Channel 3)  
No. 5Y4 (Channel 4)  
No. 5Y5 (Channel 5)  
No. 5Y6 (Channel 6)

#### HIGH BAND

No. 5Y7 (Channel 7)  
No. 5Y8 (Channel 8)  
No. 5Y9 (Channel 9)  
No. 5Y10 (Channel 10)  
No. 5Y11 (Channel 11)  
No. 5Y12 (Channel 12)  
No. 5Y13 (Channel 13)

"Long Ranger" YAGI antennas for all of the high band channels are also available in stacked array. Jumper bars for stacking of low band "YAGIS" are also available.

### FAST and EASY installation

JFD YAGI antennas are completely pre-assembled at the factory. Just swing the "Quik-Rig" elements into position and tighten the wing nuts.

These all-aluminum JFD "Long Ranger" YAGI antennas are something to shout about... because even the really remote stations are now being pulled in with satisfactory viewing results. And JFD advanced design plus sturdy construction assure durability and long-lasting, trouble-free performance. Let these superior JFD YAGI installations help you e-x-p-a-n-d your television market.



Write for FREE  
Technical Data Sheet No. 59

MANUFACTURING CO., Inc.

6105E 16th AVE., BROOKLYN 4, N. Y.  
FIRST In Television Antennas and Accessories



**"no one has ever heard a G-610 who didn't want one!"**

**We believe this statement is literally true . . .**

The Jensen G-610 loudspeaker System brings you clear, clean, life-like reproduction with thrilling transport-to-the-original such as you have never heard before. Of course G-610's are in short supply, for the government has restricted cobalt for Alnico V magnets — and the G-610 has more magnetic energy than any speaker ever built. But when restrictions are relaxed and G-610's are again plentiful, then be sure you get a G-610 . . . **NO ONE** has ever heard one who didn't want one!

*Furnished complete with Crossover and Control Network illustrated below.*

**Jensen**  
MANUFACTURING COMPANY

Division of The Muter Company

6601 So. Laramie Ave. • Chicago 38, Illinois

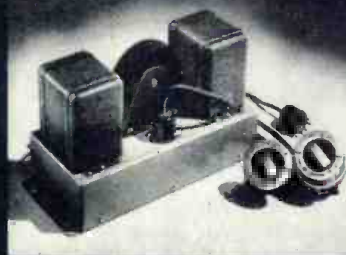

# RADIO-TV Service Industry News

**AS REPORTED BY THE  
TELEVISION TECHNICIANS LECTURE BUREAU**

**A.** C. W. SAUNDERS, educational director of the Lecture Bureau and one of the industry's most popular lecturers on practical servicing of radio and television receivers, will deliver the major talks on servicing in May at the annual Town Meeting programs for radio and television technicians which are being sponsored by the Radio Manufacturers Association of Canada.

This year, two series of meetings for technicians have been scheduled by the service committee of the Radio Manufacturers Association of Canada. These are to run concurrently with the first program scheduled for Toronto on May 14, 15 and 16, and the second in Montreal on May 15, 16 and 17. Mr. Saunders will deliver lectures in both cities by means of arrangements the committee has made to dovetail his schedule.

This is the third consecutive year that Mr. Saunders has been invited to lecture at their annual meetings by our good neighbors on the north. His current lecture on the Bureau's program, "20 Basic Points for Television Receiver Service," which has been so very popular with the technicians who have heard it, will be one of the lectures he will present at the Canadian meetings.

### **Another National Federation Formed**

The National Electronic Technicians & Service Dealers Association (NETSDA) was formed recently at a meeting in Washington, D. C., by delegates from twenty-two technician and servicing dealers associations.

The announced aims of this new organization are: (1) The furtherance and improvement of the electronic servicing industry; (2) To promote the welfare of servicing dealers and technicians; (3) To promote a better understanding between the electronic service industry and other major elements of the electronics industry; (4) To promote and secure better relations with the public; (5) To provide educational facilities for its members; (6) To raise the standards of the electronic servicing profession; (7) To cooperate with federal, state, and municipal agencies.

Deviating from the stand formerly

held by some associations in the new organization, the delegates voted to accept recognized television contracting and radio service associations as members without regard to the existence of state or regional federations in the areas where they operate.

Temporary officers selected by the delegates are Max Leibowitz of New York City, president; Norman R. Selinger of Washington, D. C., vice-president; Richard R. Devaney of Philadelphia, Pa., corresponding secretary; Roger K. Haines of Haddonfield, N. J., recording secretary; and Vance E. Beachley of Harrisburg, Pa., treasurer.

The address of NETSDA is Dorchester House, 1625 Kalorama Road, NW, Washington, D. C.

### **Price-Wage Freeze**

The television service contractor and the radio service dealer who has not maintained an accurate "breakdown" of his sales of service and parts may find himself in hot water if he doesn't establish these records of past activity immediately. Last March 1st (1951) was the "deadline" for having such records prepared. Permissible charges for both labor and parts are tied to the charges that were made for labor and for parts during the selected "base period." This base period was selected as the period between December 19, 1950 and January 25, 1951.

According to current interpretation of the regulations issued by the Office of Economic Stabilization, the service dealers must keep the following records:

1. Those records which he had on January 26, 1951 that show prices charged for goods and services during the base period. Also the records that show the latest net costs up to that date for parts and supplies which he purchased.
2. A statement of the categories of parts and supplies and a list of the services that he sold.
3. A statement showing the ceiling price for each of the services which he delivered or had available for delivery during the base period together with an identification of each.
4. If the dealer offered his customers the same services at different prices, he must maintain a record of these variations.

**RADIO & TELEVISION NEWS**



1000 KC crystal BT cut.....\$3.95  
 3" scope shield.....1.29  
 2 speed dial drive for 1/4" shaft ratios 5:1 1 to 1 .39  
 ATC 100 mfd air trimmer screwdriver shaft......29  
 Centralab 850 S 50MMF 5KV BUTTON COND..... .39  
 500 watt 12.5 ohm power rheostat..... 3.49



6v. 12v vibrators any type.....\$ .98  
 Rotary switch Mycalex, 2 deck SP3T..... .39  
 1 mfd 5000v oil condenser..... 2.98  
 2 mfd 3000v oil condenser..... 3.25  
 3 mfd 4000v oil condenser..... 3.95  
 24 mfd 1500v DC 3KV flash. Excellent for speed lamp..... 3.95

**TUBES!! BRAND NEW! STANDARD BRANDS! NO SECONDS! COMPARE! TUBES!!**

0A3/V175	\$1.69	3C23	\$ 9.95	204A	\$69.50	800	\$ 2.45	8012	\$ 3.95	0A2		12S7	
0B1/V175	1.29	3C24/24G	2.25	211	.69	810	2.95	8013	2.95	0A4G		12SL7	
0C4/V175	1.49	3C30	2.95	212E	1.95	811	2.95	8014	2.95	0B2		12SN7	
0D5/V175	1.29	3C31/C1B	3.49	215A	.19	812	2.95	8020	1.29	0Z4		12SQ7	
1B23	3.45	KC3	12.50	215B	8.95	812H	6.90	8025	5.95	01A		12SR7	
1B24	12.50	3CP1	2.25	227A/5C27	5.95	813	8.95	9001	2.25	1A3		12T8	
1B24	6.95	3CP1-S1	2.95	239C	3.95	814	3.95	9002	1.49	1A4P		14A4	
1B26	1.95	3D21A	1.95	240A	2.95	815	2.95	9003	1.49	1A5GT		14A7	
1B27	24.50	3DPIA	6.95	250TH	21.50	816	1.69	9004	1.45	1A6		14F8	
1B29	2.75	3DPI-S2A	8.95	250TLL	21.50	820	.98	9005	2.35	1A7GT		14H7	
1B32	8.95	3D21A	1.95	274B	2.65	828	12.75	9008	1.49	1A8S		14T8	
1B36	24.95	3E27	4.95	274C	2.65	830	1.25	9009	9.95	1B3/8016		14V8	
1B38	32.50	3E27	5.95	270A	9.95	820P	14.95	9010	9.95	1B4		14W7	
1N21 Xtal	1.25	3FPT7	3.95	270B	2.98	830B	3.95	9011	6.95	1B5/25S		14Z8	
1N21A Xtal	2.25	3GP7	4.95	284A	5.75	831	1.25	9012	1.49	1B7GT		15A4	
1N21B Xtal	3.25	3HP7	3.95	300B	9.95	832A	8.95	9013	1.49	1C5GT		15A7	
1N22 Xtal	1.35	4-65A	14.21	304TH	27.50	833A	37.50	9014	2.95	1D7G		15B7	
1N23 Xtal	2.25	4-65B	14.21	304TL	27.50	834A	39.50	9015	1.49	1D8GT		15C7	
1N23A Xtal	3.25	4-65C	29.95	305A	34.95	837	2.95	9016	1.49	1E5GT		15D7	
1N23B Xtal	4.95	4AP10	4.95	307A/RK75	5.95	843	.39	9017	1.49	1E7G		15E7	
1N27	1.69	4B22/EL5B	9.95	310A	8.95	843	.39	9018	1.49	1F4		15F7	
1N34	1.40	4B22/EL5C	7.95	316A	6.65	843	.39	9019	1.49	1F5GT		15G7	
1N34A	1.40	4B26/6CF	8.95	323A/B	24.50	845	4.95	9020	1.49	1G4GT		15H7	
1P23	3.95	4B26/2000	8.95	327A/5C37	4.95	849	29.50	9021	.89	1G6GT		15J7	
1P24	1.79	4B27	4.95	331A	12.95	851	69.50	9022	1.49	1G7GT		15K7	
1P36	2.95	4B27	4.95	331A	12.95	857	1.45	9023	1.49	1G8GT		15L7	
1S21	6.95	4C27/7	4.95	350A	8.95	860	6.95	9024	1.49	1H4		15M7	
2AP1	8.95	CV92	49.50	350B	2.95	861	29.50	9025	1.49	1H6GT		15N7	
2AP3	1.79	IC33	29.50	368AS	7.95	862	1.45	9026	1.49	1H7GT		15O7	
2C21/RK33	6.9	4D22	12.95	371A	1.49	865	1.45	9027	1.49	1H8GT		15P7	
2C22/7193	4.9	4D32	14.95	371B	.98	866A	1.39	9028	1.49	1J6GT		15Q7	
2C24	1.49	4E27	4.95	384A	7.95	866B	1.29	9029	1.49	1J7GT		15R7	
2C24/RK34	8.9	4E27	17.95	384B	6.95	866R	1.29	9030	1.49	1J8GT		15S7	
2C39	24.50	5AP1	3.69	393A	4.95	869	39.50	9031	1.49	1K4		15T7	
2C40	4.95	5AP4	3.69	417A	12.95	874	1.49	9032	1.49	1K6GT		15U7	
2C43	14.95	5BP1	5.95	431A	4.95	877	1.45	9033	1.49	1K7GT		15V7	
2C44	1.49	5BP4	5.95	440A	4.95	878	2.59	9034	1.49	1L4		15W7	
2C46	7.50	5CP1	4.95	446B	1.79	884	1.49	9035	1.49	1L6		15X7	
2C51	5.75	5C22	49.55	450TH	44.50	885	1.49	9036	1.49	1L7G		15Y7	
2E21	1.79	5C22	24.50	527	12.75	905	3.59	9037	1.49	1L8S		15Z7	
2E22	1.95	5D21	1.95	558	1.39	908	7.95	9038	1.49	1L9S		16A7	
2E23	4.89	5E27	4.95	728A	47.50	918	2.59	9039	1.49	1P3GT		16B7	
2E24	2.29	5GP1	24.45	775A	13.95	922	1.95	9040	1.49	1P5GT		16C7	
2E25	9.95	5HP4	24.45	701A	5.95	923	1.05	9041	1.49	1P7GT		16D7	
2E26	8.45	5J20	12.95	703A	7.95	924	1.05	9042	1.49	1P8GT		16E7	
2E27	29.50	5J30	49.50	704A	1.05	930	1.05	9043	1.49	1P9GT		16F7	
2E28	2.29	5J30	49.50	705A	3.95	931A	4.95	9044	1.49	1Q4		16G7	
2E29	2.29	5J30	49.50	706B	39.50	931B	4.95	9045	1.49	1Q5GT		16H7	
2E30	2.29	5J30	49.50	706C	39.50	931C	4.95	9046	1.49	1Q6GT		16I7	
2E31	2.29	5J30	49.50	706D	42.50	931D	4.95	9047	1.49	1Q7GT		16J7	
2E32	2.29	5J30	49.50	706E	42.50	931E	4.95	9048	1.49	1Q8GT		16K7	
2E33	2.29	5J30	49.50	706F	42.50	931F	4.95	9049	1.49	1Q9GT		16L7	
2E34	2.29	5J30	49.50	706G	42.50	931G	4.95	9050	1.49	1R4		16M7	
2E35	2.29	5J30	49.50	706H	42.50	931H	4.95	9051	1.49	1R5GT		16N7	
2E36	2.29	5J30	49.50	706I	42.50	931I	4.95	9052	1.49	1R6GT		16O7	
2E37	2.29	5J30	49.50	706J	42.50	931J	4.95	9053	1.49	1R7GT		16P7	
2E38	2.29	5J30	49.50	706K	42.50	931K	4.95	9054	1.49	1R8GT		16Q7	
2E39	2.29	5J30	49.50	706L	42.50	931L	4.95	9055	1.49	1R9GT		16R7	
2E40	2.29	5J30	49.50	706M	42.50	931M	4.95	9056	1.49	1S4		16S7	
2E41	2.29	5J30	49.50	706N	42.50	931N	4.95	9057	1.49	1S5GT		16T7	
2E42	2.29	5J30	49.50	706O	42.50	931O	4.95	9058	1.49	1S6GT		16U7	
2E43	2.29	5J30	49.50	706P	42.50	931P	4.95	9059	1.49	1S7GT		16V7	
2E44	2.29	5J30	49.50	706Q	42.50	931Q	4.95	9060	1.49	1S8GT		16W7	
2E45	2.29	5J30	49.50	706R	42.50	931R	4.95	9061	1.49	1S9GT		16X7	
2E46	2.29	5J30	49.50	706S	42.50	931S	4.95	9062	1.49	1T4		16Y7	
2E47	2.29	5J30	49.50	706T	42.50	931T	4.95	9063	1.49	1T5GT		16Z7	
2E48	2.29	5J30	49.50	706U	42.50	931U	4.95	9064	1.49	1V4		17A7	
2E49	2.29	5J30	49.50	706V	42.50	931V	4.95	9065	1.49	1V5GT		17B7	
2E50	2.29	5J30	49.50	706W	42.50	931W	4.95	9066	1.49	1V6GT		17C7	
2E51	2.29	5J30	49.50	706X	42.50	931X	4.95	9067	1.49	1V7GT		17D7	
2E52	2.29	5J30	49.50	706Y	42.50	931Y	4.95	9068	1.49	1V8GT		17E7	
2E53	2.29	5J30	49.50	706Z	42.50	931Z	4.95	9069	1.49	1V9GT		17F7	
2E54	2.29	5J30	49.50	707A	42.50	931A	4.95	9070	1.49	1W4		17G7	
2E55	2.29	5J30	49.50	707B	42.50	931B	4.95	9071	1.49	1W5GT		17H7	
2E56	2.29	5J30	49.50	707C	42.50	931C	4.95	9072	1.49	1W6GT		17I7	
2E57	2.29	5J30	49.50	707D	42.50	931D	4.95	9073	1.49	1W7GT		17J7	
2E58	2.29	5J30	49.50	707E	42.50	931E	4.95	9074	1.49	1W8GT		17K7	
2E59	2.29	5J30	49.50	707F	42.50	931F	4.95	9075	1.49	1W9GT		17L7	
2E60	2.29	5J30	49.50	707G	42.50	931G	4.95	9076	1.49	1X4		17M7	
2E61	2.29	5J30	49.50	707H	42.50	931H	4.95	9077	1.49	1X5GT		17N7	
2E62	2.29	5J30	49.50	707I	42.50	931I	4.95	9078	1.49	1X6GT		17O7	
2E63	2.29	5J30	49.50	707J	42.50	931J	4.95	9079	1.49	1X7GT		17P7	
2E64	2.29	5J30	49.50	707K	42.50	931K	4.95	9080	1.49	1X8GT		17Q7	
2E65	2.29	5J30	49.50	707L	42.50	931L	4.95	9081	1.49	1X9GT		17R7	
2E66	2.29	5J30	49.50	707M	42.50	931M	4.95	9082	1.49	1Y4		17S7	
2E67	2.29	5J30	49.50	707N	42.50	931N	4.95	9083	1.49	1Y5GT		17T7	
2E68	2.29	5J30	49.50	707O	42.50	931O	4.95	9084	1.49	1Y6GT		17U7	
2E69	2.29	5J30	49.50	707P	42.50	931P	4.95	9085	1.49	1Y7GT		17V7	
2E70	2.29	5J30	49.50	707Q	42.50	931Q	4.95	9086	1.49	1Y8GT		17W7	
2E71	2.29	5J30	49.50	707R	42.50	931R	4.95	9087	1.49	1Y9GT		17X7	
2E72	2.29	5J30	49.50	707S	42.50	931S	4.95	9088	1.49	1Z4		17Y7	
2E73	2.29	5J30	49.50	707T	42.50	931T	4.95	9089	1.49	1Z5GT		17Z7	
2E74	2.29	5J30	49.50	707U	42.50	931U	4.95	9090	1.49	1Z6GT		18A7	
2E75	2.29	5J30	49.50	707V	42.50	931V	4.95	9091	1.49	1Z7GT		18B7	
2E76	2.29	5J30	49.50	707W	42.50	931W	4.95	9092	1.49	1Z8GT		18C7	
2E77	2.29	5J30	49.50	707X	42.50	931X	4.95	9093	1.49	1Z9GT		18D7	
2E78	2.29	5J30	49.50	707Y	42.50	931Y	4.95	9094	1.49	1Z0GT		18E7	
2E79	2.2												

# the **chicago** V.T.V.M. ELECTRONIC MULTITESTER

A versatile new Chicago Vacuum Tube Volt Meter with more ranges and greater utility—at the lowest price in the industry!

**\$39<sup>00</sup>**  
net



The big 5½" meter is mounted in a handsome brown Hammerloid case slanted for easy reading.

See Your Parts Distributor or Write for Complete Information

- RANGES**
- DC VOLTS**  
0-5, 10, 50, 100, 500, 1000, 5000. Input impedance: 20 megohms (including 10 megohms in the DC probe)
- AC VOLTS**  
0-5, 10, 50, 100, 500, 1000, 5000  
Input impedance: 10 megohms
- OHMS**  
0 to 1000 megohms in 6 ranges with center scale readings of 10, 100, 1000, 10K, 1Meg., 10Meg.
- CAPACITANCE**  
50 MMF to 5000 MF in 6 ranges. Low voltage power source enables testing of electrolytic condensers.
- MILLIAMPERES**  
DC 0-1, 10, 100, 500  
(Not electronic) 50 millivolt drop.  
Operates on 115 V.A.C. Dimensions: 6¾" Wide x 9½" High x 6" Overall Depth

## CHICAGO INDUSTRIAL INSTRUMENT CO. 536 W. ELM ST. • CHICAGO 10, ILL.

**"A CUTIE"**  
0-1 MA. Meter. Total size only 1 7/8" Diameter. Flush mounting — Aluminum case. Ideal for limited space.  
ONLY \$4.95 each

### PEAK ELECTRONICS COMPANY

188 Washington St., New York 7, N. Y.  
Phone COrtland 7-6443, 7-6486

### SIGMA SENSITIVE RELAY

S.P.D.T. adjustable from 700 Microamps to 1.5 MA, 8000 ohm coil...\$2.75 ea.

### PANEL METERS

GE—General Electric  
WH—Westinghouse  
W—Weston S—Simpson  
SU—Sun \*—Special Sale  
S—Square Case

- 2" Meters**
- 0-100 UA, GE. \$6.95
  - 0-5 MA, S, SQ. 2.95
  - 0-5 MA, GE. 2.45
  - 0-15 MA, GE, SQ. 3.95
  - 0-20 MA, S. 1.95
  - 0-25 MA, SU. 1.95
  - 0-50 MA, SU, SQ. 1.95
  - 0-1 AMP RF, GE. 2.95
  - 0-2 AMP RF, S, SQ. 2.95
  - 0-4 AMP RF, GE. 2.95
  - 0-30 AMP DC, GE. 2.95

- 3" Meters**
- 0-150 VAC, GE, SQ. \$7.95
  - 0-5 KVDC, S. 9.95
  - 0-2 MA, S. 4.50
  - 0-5 MA, GE, SQ. 3.95
  - 0-20 MA, WH. 2.95
  - 0-20 MA, S. 3.95
  - 0-20 MA, GE, SQ. 3.95
  - 0-30 VOLT DC, DA. 2.75
  - 0-200 MA, GE. 4.50
  - 0-1 VOLT, AC REC-T I F I E R TYPE (500 MA movement) W. 6.95

- OIL CONDENSERS**
- 1.75 mfd 600 vdc \$0.39
  - 6 mfd 600 vdc .35
  - 8 mfd 600 vdc 1.79
  - 10 mfd 600 vdc 1.95
  - 4 mfd 1000 vdc 1.95
  - 2 mfd 2000 vdc 2.95
  - 10 mfd 2500 vdc 4.95
  - 2 mfd 4000 vdc 6.50
  - 1 mfd 5000 vdc 4.50
  - 1.1 mfd 7000 vdc 2.95
  - 2 mfd 6000 vdc 1.25

- PIGTAIL MICAS**
- MMF: S. 20, 50, 60, 100, 250, 300, 400, 500, 750, 800, 1000, 2000, 3000, 4000, 5000, 6000, 10000...\$0.09 ea.

- Ceramics**
- MMF: 20, 120, 500...\$0.05 ea.

- Silver Mica Capacitors**
- MMF: 10, 50, 60, 340, 750, 780, 1000, \$0.12 ea.
- CHOKE BARGAINS**
- 6 Hy, 40D MA, C \$3.95
  - 5 Hy, 250 MA, C 2.95
  - 5 Hy, 170 MA, C 1.75
  - 6 Hy, 50 MA, C .99
  - 8 Hy, 175 MA, C 1.95



### PANEL METER KIT

Here's what you get:  
● 2" sq. bakelite cased meter, Gov't. Supp use  
● Scales for all the following ranges: 0-50 ma, 0-100 ma, 0-200 ma, 0-500 ma.  
● Pre-calculated shunt sizes for all ranges  
● Complete instructions. Only \$2.50 ea. 3 for \$6.75



### HIGH CURRENT MICAS

CAP	MFD	TYPE G1	Price
.00024	1 Mc	DC	Each
.00024	4	6	\$ 4.95
.0004	4.7	6	4.95
.001	7.5	6	5.50
.004	15	6	5.95
TYPE G2			
.0003	6	10	\$ 9.95
.005	20	5	9.95
TYPE G3			
.00015	8.2	20	\$15.95
.0012	16	15	17.95
.0025	22	12	17.95
.005	30	8	17.95
TYPE G4			
.001	17	30	\$34.50
.002	22	20	34.50
.0039	30	20	34.50
TYPE G5			
.0001	6	35	\$32.50
.00015	10	35	37.50
.0005	20	35	42.00

- 1 1/2 W. W. Resistors**  
Ohms: 2K, 5K, 8500  
50K, 100K...\$0.45 ea.
- Non-Inductive Resistors**  
Ohms: 500, 12,500, 100 watts...\$0.75

### RAYTHEON SWINGING CHOKE

- 2 to 12 Henrys, 1 Amp to 100 Ma, 15 Ohms DC fully cased. High voltage insulation, ceramic insulators. Very conservatively rated. Weight 60 Lbs. ....\$16.95 ea.
- Meter Multipliers**
- 1 Meg. 1/5 of 1% Cage Enclosed 1 KV...\$2.95
  - 2 Meg 1/2 of 1% Tubular 2 KV...\$2.95
  - 4 Meg 1/2 of 1% Tubular 4 KV...\$3.95

- GE KV METER**
- 0-15 KV DC. 3 1/2" SQ. Bakelite case. 500 UA movement. Includes 30 Meg. 1% Ext. multiplier...\$15.75 ea.

**BAKELITE CASED MICAS**

MFD	VDC	Price	MFD	VDC	Price
.001	600	\$ .18	.024	1500	\$.95
.002	600	.24	.033	1500	.75
.01	600	.26	.02	2KV	.90
.02	600	.26	.005	2500	.55
.027	600	.26	.002	2500	.45
.01	1KV	.45	.005	3KV	1.00
.002	1200	.35	.0001	5KV	.70
			.0005	8KV	2.90

**WIRE WOUND RESISTORS**

- 5 watt ohms: 25-50-200-2500...\$.09 ea.
- 10 watt ohms: 25-40-84-400-1325-2K-4K...\$.15 ea.
- 20 watt ohms: 50-70-100-300-750-1K-1.5K...\$.20 ea.
- 2.5K-2.7K-5K-16K-20K...\$.22 ea.
- 30 watt ohms: 100-2500-5300-18K...\$.22 ea.
- 100 watt ohms: 100-3750-1500-2K, 10K, 20K, 25K, 50K, 75K...\$.59

- GUARDIAN LATCHING RELAY**  
SPDT, 110 V 60 cy Coil, 15 Amp Contacts...\$1.95

- ADJUSTABLE SLIDER RESISTORS**
- 20 Watt: 1, 5, 300 ohms...\$0.25
  - 50 Watt: 500 Ohms...\$.35
  - 75 Watt: 100, 150, 200 Ohms...\$.39
  - 100 Watt: 50, 75, 100 Ohms...\$.49

- MISCELLANEOUS BARGAINS**
- 25 ohm 675 watt Rheostat...\$2.95
  - 50 watt 35 watt Resistor...\$.99
  - 250 mfd Midget Var. Ceramic Ins...\$.69
  - 15 mfd Midget Var. Ceramic Ins...\$.39
  - 4PST Lever Switch Mossman...\$.89
  - Ceramic RF Switch SP 11 Pos...\$.89
  - .02 600V Tubular...\$.15 for .99
  - .05 600V Oil Tubular...\$.12 for .99
  - 10K, 15K Pot...\$.49
  - 16 mfd 450 V. Electrolytic...\$.39
  - 5-20 mfd Ceramic Variable...\$.24
  - 1.5-7 mfd Ceramic Variable Ins...\$.24
  - SPST Push Button Switch...\$.29
  - 5x5 MFD 400 VDC Oil...\$.59
  - 1x1x1 MFD 1200 VDC...\$.59
  - 100 mfd Air Paddle APC 100...\$.49
  - 50 mfd Air Paddle APC 50...\$.39
  - Fil Transf. 2 1/2 V CT, 40 AMPS, 110V CY...\$.695

- HIGH WATTAGE ANTENNA RELAY**  
110/220 Volt 60 Cy. coil. 5000 Volt, 15 Amp contacts, DPST. Ceramic insulation...\$9.95 ea.

And the regulations require that the following current records must be maintained by the service dealer:

1. A record of the prices which he charged for his services.
2. The necessary records to establish the basis for his ceiling prices under the regulation.
3. Purchase invoices for parts and supplies on which he should record his initial selling prices and the section of the regulation under which he has determined his ceiling price.

### Critical Materials Conservation

The recent announcement by RCA detailing the accomplishments of its engineering research program in conserving critical materials underlines a number of changes that will be showing up in the parts and equipment used by the service industry. Outstanding among the engineering accomplishments described in the report are the development of a new electrostatic-focus television picture tube and the radical redesign of loudspeakers used in both radio and television receivers.

It is said that the performance of RCA's new electrostatic kinescope is fully comparable with the performance standards of the electromagnetically-focused tubes now in use and that electrostatic focus is readily adaptable to all sizes of television picture tubes.

There was a substantial saving in the use of critical materials effected by the RCA Service Company, according to the report. An estimated saving of 50% in aluminum used for antenna masts during the first quarter of 1951 was accomplished through the use of smaller tubing and stronger alloys which permitted a reduction in wall thickness of the aluminum tubing used. The measures now in effect have reduced the consumption of copper in transmission lines by as much as 33% with tests now underway with "copper-weld" or copper-coated steel wire promising a future reduction of 82% in the copper used.

RCA's revised specifications for some of the parts that they buy point up some of the changes that may be expected in replacement parts. These include:

1. The cup over the end of the kinescope on the rear of the cabinet has been changed from aluminum to plastic.
2. Shorter mounting bushings on some variable controls, saving approximately 10% of the brass in these controls.
3. Reduction in the length of copper wire leads on paper and ceramic condensers (20% copper saving).
4. The use of copper clad steel wire instead of copper wire leads on wire-wound resistors and chokes.
5. The use of Alnico 3 magnets (no cobalt required) for beam benders, instead of Alnico V magnets.

### Service Organization Activities

The unusual organizational progress of the Television Installation Service Association of Omaha, Nebraska, and

## Beat the Tube Shortage!

This invaluable book shows you how to keep radio and TV sets working . . . even though exact replacements are unavailable.

### RECEIVING TUBE SUBSTITUTION GUIDE BOOK



For TV-AM-FM Receivers and Allied Equipment  
by H. A. Middleton

2500 Radio and TV tube substitutions listed: TV receiver filament wiring; heater substitution wiring instructions; tube types classified by functions. Other priceless data you must have in order to keep your shop as well as receivers going. Get this book without further delay.

215 pages, 8 1/2 x 11, durable paper cover.  
Only \$2.40

## All About the Scope!

WHAT it is . . . WHAT it can DO . . . and HOW to use an oscilloscope PROPERLY for greater profit to you!

### ENCYCLOPEDIA ON CATHODE-RAY OSCILLOSCOPES AND THEIR USES

by John F. Rider and Seymour D. Uslan

The ONLY book that so fully describes the oscilloscope . . . its applications in servicing, engineering, research . . . with thousands of time-saving and labor-saving references, charts, waveforms, etc. More than 70 different models are described with specifications and wiring diagrams. WE GUARANTEE that it will EARN many times its cost to you. 992 pages, 8 1/2 x 11. 500,000 words, 3000 illustrations. 22 chapters. Completely indexed, easy to read. Cloth bound.



Only \$9.00

## About Master Antennas

Master Antenna Systems are a big business. Make sure you get your share by making sure you know all about installations.



### TV MASTER ANTENNA SYSTEMS

by Ira Kamen and Richard H. Dorf

More than 50 million dollars will be spent in 1951 for TV Master Antenna Systems installed in apartment buildings, hotels, hospitals, institutions, etc. . . . in both new and old buildings. This book provides a practical working manual that deals with installation, usage, maintenance, etc. It shows how the Master Antenna System is installed, how it works, and how you can capitalize on this fast-growing field.

356 pages. 234 illustrations. Cloth bound.  
Only \$5.00

## Time-Saving! Money-Making!

Stop wasting time, effort and money in trying to "dope out" difficult TV installations . . . order this book today.



### TV INSTALLATION TECHNIQUES

by Samuel L. Marshall

The only book of its kind. Gives ALL the facts about such things as ice loading, wind surface, mounting requirements, etc. Accurate data on receiver adjustment in the home. Municipal regulations in all the major TV areas in U.S.A. Complete information on all mechanical and electrical considerations. Sure to be a great help to you.

330 pages, 5 1/2 x 8 1/2. 270 illustrations. Cloth bound.  
Only \$3.60

At Your Jobber's or ORDER DIRECT on a 10-DAY MONEY-BACK GUARANTEE.

JOHN F. RIDER PUBLISHER, Inc.  
480 Canal Street • New York 13, N. Y.

the effectiveness of its program is clearly indicated by the budding interest in other farm-belt cities in the formation of similar associations. Headed up by Jim Hustad, who is also secretary of the National Association of Television and Electronic Service Associations, the Omaha association was organized after Messrs Hustad and Briza made several trips to visit other organizations to observe their organizational structures and plans of operation.

Massachusetts radio and television service dealers were rudely shaken earlier this year when they discovered that a bill to license and regulate television servicing and sales in the Commonwealth of Massachusetts was in the legislative hopper. Benjamin S. Sims, president of the Boston chapter of the Radio Television Technicians Guild, reported to the members of the Guild that:

"As an indication of what almost happened, is the fact that licensing of all radio and television servicemen almost became a reality during the past few days. If the manufacturers and distributors for two major companies had not intervened and blocked the licensing plan we would have lost a business and the privilege of servicing television sets or radios until we secured a license."

While space in this column does not permit a discussion of the features of the bills that were presented to the Massachusetts legislature, it must be pointed out that if these regulations had become laws they would have tied the entire radio and television retailing and servicing industry as it is now operated in that state, in a straight-jacket. Although we decry these political attempts to regulate our businesses we would be less than honest if we didn't point out that the entire industry—manufacturers, distributors, dealers, and service operators—have been really asking for it in their pusillanimous efforts to solve the basic problems of the retail selling and servicing of television receivers. The growing concern and alarm of the National Better Business Bureau over the continuing flood of user complaints that keep flowing into BBB offices from coast-to-coast indicate that if the entire industry doesn't get together to correct the evils that beset the business—politicians will.

Television Associates, Inc., of Washington, D. C., is carrying out a program to unite the service industry in the capital. Originally organized as an association of television installation and service contractors the organization structure was revised to include radio service dealers and service technicians.

### "TV Tuner"

What is undoubtedly the most pre-tentious house organ ever launched by a radio or television service association made its debut in Philadelphia recently. It's title is the "TV Tuner" and it is the official publication of the

# You need it! Get it...Now!

## New Rider TV Manual... VOLUME 6



at your nearby Jobbers' today! Hurry in for your copy before the present supply is exhausted!

## EXCLUSIVE FEATURES

- All TV Production Runs and Changes from August, 1950 Through January, 1951.
- Circuit Function Descriptions.
- Unpacking and Installation Data.
- Signal Waveforms for Trouble Shooting.
- COMPLETE Alignment Data.
- COMPLETE Parts List.
- Circuit Changes.

## RIDER TV MANUAL...Vol. 6

ACCURATE . . . AUTHENTIC . . . FACTORY-AUTHORIZED TV servicing information direct from 66 manufacturers. BIG 12"x 15" page size, and all pages filed in proper place. Large, easy-to-read diagrams. Equivalent of 2320 pages, (8 1/2" x 11") plus Cumulative Index Volumes 1 through 6 . . . \$24.00

With all 6 RIDER TV MANUALS on your shelves you will have the world's greatest compilation of TV servicing information—right at your fingertips. This information will save you time, save you trouble, help you do a better servicing job, and help increase your profits. SEE YOUR JOBBER TODAY!

Now Available!

## RIDER Manual . . . Vol. XXI



Here's another RIDER volume that you must have on your shelves...another time-saver . . . another money-maker for you! Factory-authorized servicing information from 61 manufacturers . . . AM-FM,

Auto Radios, Record Changers, Disc Recorders, Tape Recorders. Coverage from December, 1949 through October, 1950. 1648 pages plus Cumulative Index Volumes XVI through XXI . . . \$21.00

Every Day, More and More Servicemen Buy RIDER MANUALS For PLUS Profits!

JOHN F. RIDER PUBLISHER, Inc.  
480 Canal Street • New York 13, N. Y.

# It's To Your Advantage To Use ERIE CERAMICONS<sup>®</sup>

*because...*

- They are compact in size . . .  
Impervious to humidity . . .  
Rugged in construction . . .  
100% tested to assure highest quality  
Conservatively rated
- A wide range of capacitance values  
and temperature characteristics avail-  
able in molded and dipped insulated  
types . . . Especially adaptable to  
replace paper and molded micas . . .
- Economically priced . . . Available  
through distributors everywhere



*Electronics Division*  
**ERIE RESISTOR CORP., ERIE, PA.**  
LONDON, ENGLAND . . . TORONTO, CANADA

## Tower, Mast and Antenna Support Headquarters

- Guyed supporting towers for TV-FM antennas
- TRYLON Vertical Radiators
- Micro-wave relay towers
- Complete antenna systems with switching units
- Communications antenna supports . . . and dozens of special items

Hundreds of installations in all parts of the world, under all conditions of use attest to Trylon Tower dependability. As specialists in antenna supports for over 18 years, Trylon offers a broad, time-tested line of standard units plus complete facilities for the economical production of special types and designs.

Write for literature on any desired type—or, better yet, outline your antenna support problem for recommendation by Trylon specialists.

*Trylon Towers are made only by*

**WIND TURBINE CO.**

WEST CHESTER, PA.



Television Contractors Association of Philadelphia. Edited by Paul V. Forte, executive secretary of the association, it pioneers an idea that can be indispensable for expanding the interest and active participation of good radio and television service businessmen in cleaning up the service phase of television in their local areas.

The initial issue, a twelve-page, 9 x 12 slick paper edition, is devoted chiefly to news of the many activities of TCA, its officers and its members. However, we were particularly impressed with one article in this issue that is typical of the incisive thinking of this association in matters that affect the television servicing industry.

The article, titled "Banks Asked to Recognize Their Position in TV Industry," points clearly to one potential control factor to prevent contracts for the initial installation and service of new receivers from getting into the hands of incapable or unreliable service operators.

"Banks and various credit agencies are some of the little known members of the television industry. Without money and credits TV, like any industry, would fold up and die. These agencies have profited greatly from the efforts of manufacturers, distributors, dealers, and service contractors but they have disclaimed any responsibility to the industry other than providing money at a profit.

"For a long time many service contractors, including the members of the Television Contractors Association, have been trying to tell the banks that they should develop an interest in television service. They have tried to point out that if service were poorly or dishonestly handled it would seriously interfere with their collections on the 'paper' they handle.

"The time is at hand, the Television Contractors Association believes, when banks and credit agencies should take drastic steps to insure their loans by making sure that all financed sets are serviced by competent and reliable contractors.

"The banks have the biggest weapon of all—money!—in helping the industry to rid itself of the undesirables, the fly-by-nights, the unscrupulous, the ignorant, and the incompetent. They should cooperate with the Television Contractors Association in helping to establish standards of responsibility and performance for the entire industry in Philadelphia, and then make certain that no contractor who cannot meet the requirements handles any set they finance."

Organization officers who would like to examine a copy of the "TV Tuner" should address their requests to: Television Contractors Association, MIT Corporation Building, Philadelphia 3, Pa.

### TISA Plugs Industry Problems

The Television Installation Service Association of Chicago has been pounding on the doors of industry for a long time seeking recognition for the tele-

**RADIO & TELEVISION NEWS**



# TOP ITEMS AT LOWEST PRICES



## BC-438 BEACON RECEIVERS

Similar to BC 1206. Manufactured by Tetra Radio. 200 to 500 KC. Far Direction Finder. Contains 2-2510, 1-6SA7, 1-6SF7, 1-6SK7, 1-6K7. Excellent condition. Complete. **\$7.95**

BC-357 FREQUENCY RANGE. 60 to 80 Mc. With Tubes **\$3.95**  
 BC-1033 Operates from 24 Volts D.C. **4.95**



## 2 VOLT WET CELL RADIO BATTERY

NEW. Uncharged (Appr. wt. 4 lbs.) TYPE 20-2 **\$1.45**  
 Complete set of three with Box and Connections to make a 6 volt, 20 Amp. Hrs. Battery Uncharged (Approx. wt. 15 lbs.) Set **\$5.95**

## MG-149F INVERTER

Input 24 Volt DC 30 Amps. 110 v. 400 Cy. AC. 500 V.A. Output at 90% P.F. Used, excellent condition **\$8.95 ea.**

## MIDGET SELSYNS

AY type operates from 6-12 Volts 60 Cycles. Use as both transmitter and receiver. These compact little units draw almost no current and work fine for all remote position indicating applications. OD 2 1/4 x 2 1/4". All New (Appr. wt. 1 lb.) **\$1.50**

## PROP PITCH MOTORS



For your Beam Antenna: 20 Volt to 32 Volt, A.C. or D.C. 1/2 H.P. Motor; 1 1/2 RPM Gear Reduction, 7000 to 1. ALL BRAND NEW **\$13.95 ea.**

## DYNAMOTORS

CW 21215. 330 Volts @ 170 MA Output. 12 Volts DC Input. New **\$7.95**

## COMMAND RECEIVERS

3 MC to 6 MC. **\$6.95 ea.**  
 6 to 9 Meg. Approx. weight of each 12 lbs. All used but complete and in good condition. **6.95 ea.**

## COMMAND TRANSMITTERS

3 to 4 MCS \$14.95 ea. 5.3 to 7 Meg. **\$4.95 ea.**  
 7 to 9 Meg. **\$14.95 ea.** Complete with Tubes and Crystals, excellent condition.

## BC 456 MODULATION UNIT

Part of SCR274K. Equipment contains Relays, Transformers and 1235, 1425 and VII 150 (OD3) Tubes. Less Tubes **\$1.50**  
 With Tubes **2.95**

## CONDENSER BUYS

2 UFD 400V VDC Pyranol **\$2.95**  
 1 UFD 600 VDC **49c**

## WALKIE TALKIE BATTERIES

BA 37-1 1/2 volt-A **\$5.0c**  
 BA 38-103 1/2 volt-B **\$1.29**  
 Both for **\$1.50**

## SOLDERING IRONS

Famous Name Manufacturer. 85 watt Iron. Only special purchase permits this low price, which is much less than standard advertised price. All brand new **\$2.95**

## RU 16 RECEIVERS

RU 16 RECEIVERS **\$5.95 Ea.** Plug-in Coils.  
 9 Ranges 100-13570 KC **1.50 Ea.**  
 BC 430 Transmitter **5.95 Ea.** Plug-in Coils for Trans.  
 2 MEG-9 MEG **1.50 Ea.**  
 12 Volt Dynanotor for above. **7.95 Ea.**  
 330 Volt @ 170 MA. **7.95 Ea.**  
 RU-19 Control box **1.00 Ea.**

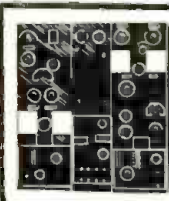

## MODEL 60-9 TRANSMITTER

All brand New. 100 Watts CW. or MCW. emission. Operates from 110 V., 800 Cycle, easily converted to 60 Cycle operation. Low frequency range, 300 KC. to 600 KC. High frequency 3,000 KC. to 18,000 KC. using an F.C.O. We furnish complete conversion data with each transmitter. Complete with schematics. **\$59.95**

All Mail Orders Promptly Filled, F.O.B. San Francisco stock and prices on Radio, Electronics, Tools, Hardware,



## RU-19 RECEIVERS

For the first time on surplus, we can now offer this versatile Receiver. All complete and ready for 12 volt operation. These units are ideal for ship-to-shore receivers, ADI, and mobile operation. They come complete with 9 coils covering frequency range of 195 KC to 13570 KC. 12 volt dynamotor, all interconnecting cables, remote tuning head and cables, spare tubes, tuning meter, instruction manual, junction box, mounts, etc., etc. **NOTHING ELSE TO BUY. ALL BRAND NEW. COMPLETE \$39.95**

## METERS

Westinghouse—G.E. Weston

MILLIAMPERE D.C. **KILOVOLT D.C.**  
 3"-0 to 50. **\$3.95 Ea.** 3"-0 to 400 DC. **\$3.95 Ea.**  
 3"-0 to 100. **3.95 Ea.** 3"-0 to 500 DC. **3.95 Ea.**  
 3"-0 to 150. **3.95 Ea.** 3"-0 to 4. **3.95 Ea.**  
 3"-0 to 200. **3.95 Ea.** (All are 1 Ma. full scale, require external multiplier.)  
 3"-0 to 250. **3.95 Ea.**  
 3"-0 to 300. **3.95 Ea.**  
 3"-0 to 750. **3.95 Ea.**

VOLT METERS  
 3"-0 to 8 AC. **\$2.95 Ea.**  
 2"-0 to 15 AC. **2.95 Ea.**  
 2"-0 to 30 DC. **3.95 Ea.**  
 3"-0 to 150 DC. **3.95 Ea.**

2" WESTON SPECIAL  
 0 to 30 V. DC and 0 to 120 Amps. DC **\$3.95 Ea.**  
 0 to 30 V. DC and 0 to 240 Amps. DC **3.95 Ea.**

TIME HOUR METERS  
 99999.9 Hrs.  
 10-12 Volts. 60 Cycle 3 Inch **\$6.95 Ea.**

## RADIO COMPASS RECEIVERS

RS-ARN 7-180 KC to 1,750 KC **\$34.95**  
 MN 20-150 to 1500 KC **\$34.95**  
 BC 433-100 to 1750 KC **\$24.95**  
 All in excellent condition, with tubes.

## ALTIMETERS

Sensitive type—ideal for planes or automobiles. 0 to 40,000 ft. operate from Barometric pressure. No wheel hubokup needed. Excellent condition. Low priced at **\$7.95**

## MISCELLANEOUS SPECIALS

9 Channel Push Button Switch, spring lock type **\$1.00**  
 300 OHM Twin Lead **.04 per Ft.**  
 67 1/2 Volt Radio "H" Batt. **1.00 Ea.**  
 1 L.B. Roll In-Basin Core Solder. **.95 Roll**  
 BC000G Interphone Switch Box. **.58 Ea.**  
 RG 7U COAX 950 OHM. **.06 per Ft.**  
 J-5A Hand Keys, Flameproof, New. **.69 Ea.**



## FL-8 FILTER

Range or Voice for 1020 cycles Audio. Switch mounted on Filter. Excellent for C W. **\$1.25**

## DESK TELEPHONES

French Type, Western Electric, Kellogg Monophone, etc. Can be used for rural service, extension phone or remote control apparatus. With Dial **\$12.95**  
 Less Dial **9.85**

## GIBSON GIRL

The Emergency Radio Transmitter. Send S O S signals automatically on 500KC. 150-mile range. No batteries required. Has handdriven Generator, tubes, carrying case. New. It's only **\$5.95**

## BLACKLITE UNIT

4 Watt Fluorescent Lamp mounted in a goose-neck holder. Starter mounted in base. Requires only 500 OHM Resistor in series with line for 110 V. AC operation. Ideal for radiation of Fluorescent Mirrors or Matchless. **\$1.95 Ea.**  
 Extra 4 Watt Blacklite Lamp **\$1.00**

## DC GENERATOR

12 Volt DC Output @ 4 Amp. Must be belt-driven @ Approx. 2000 RPM. In good condition **\$4.95**

## JEEP GENERATORS

12 Volt DC Output @ 60 Amp. Complete with Voltage regulator and Ammeter. Ideal for Boats, Trucks or Mobile Radio use. Excellent condition **\$49.95**

## 12 VOLT BLOWER MOTOR

Trade Winds Blower—Operates from 12 volts DC @ 0.6 AMPS. Diameter of case 7". Ideal for Boats or Trucks. In Good condition **\$4.95**

## POLE INSULATORS

Glass 2" Insulator with 3" screw overall length 5" for telephone use **\$10.00** Hundred



## BRASS SELSYNS

Heavy Duty Bendix Selsyns. 110 volts 60 Cycles AC. **Pair \$9.95**

## GYRO MOTOR UNITS

Dual gyro unit. Both gyro motors mounted on single base. Wired in parallel for 12 or 24 volts. Excellent condition. (Please specify if you wish the 12 or 24 volt) **\$4.95**

## SOUND POWERED HAND SETS

TS-10 type—Various manufacturers. No batteries needed for operation. Use in pairs with wire. Available up to 10 miles. Ideal for TV antenna installations, etc. Excellent condition **Pair \$17.95**

## PE 110 POWER SUPPLY

This unit was used as part of BC609 transmitter. Input 110 volts 60 watts. Output 545 volt @ 455 ma. for transmitter and low voltage supply for receiver and Filaments. Uses 4-5Z3 tubes for high voltage and 1-60 tube for low voltage. Also contains a 12 volt vibrator pack for receiver voltages. This supply is well filtered and regulated and is ideal for your Ham transmitter. Low priced at **\$34.95**

## INTERVALMETERS

This unit was used to release bomb loads at different time intervals and now can be used ideally for dark room timers, etc. Complete with two 6X6 tubes; four sensitive relays and other related parts. Excellent Condition **Each \$4.95**

## TG-5 CODE OSCILLATOR

Battery operated Code Practice Oscillator. Use singly for practice or can be used in pairs for practice or sending messages over wire between two points. Uses a 22 1/2 volt dry cell battery and 2 flash light cells. Contains keying relay and 1000 Cy. tone buzzer and head set. All brand new, with canvas carrying case **Ea. \$9.95**

## BC-605 INTER-PHONE AMPS.

(See conversion of this Unit on Page 140 in April issue—Radio-Tel. News). Ideal for Inter-Com. Office to office; airplane inter-com, etc.; Complete with Tubes, Diagram and Case. Easily converted. Excellent condition. **\$3.95 ea.**

## MINE DETECTOR. AN PRS-1

Easy to operate, easy to carry. Can be used for detecting ore deposits, both metallic and non-metallic. Now being used extensively by Miners, Prospectors, Beachcombers, and Explorers. These sets are brand new and come complete with Detector head with antenna; Reflector meter and housing and exploring rod; a bag for carrying equipment while operating and a wooden case for storing or transporting unit when not in use. These units contain Tubes, and instruction books. Shipping weight is 125 lbs. Weight when operating unit is 25 lbs. All New—Complete with Batteries and ready to operate **Set \$29.95**  
**SCR-625 MINE DETECTOR. \$59.50**  
 Complete with batteries

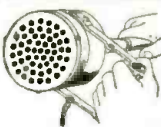

## HAND SIRENS

All New, with canvas cover carrying strap. Can be heard for many miles. Ideal for Civil Defense, Camps, etc. A bargain at **\$9.95**

## G.P.7 TUNING UNITS

6 Ranges: A-350-800 KC. B-800-1500 KC. C-1500-3000 KC. D-3000-4325 KC. E-4325-6500 KC. F-6200-9030 KC. Also contains Capacitors, Resistors, Vernier Dials and many other parts. A REAL BUY **\$4.95** while they last. Each unit range

## WATERTIGHT SWITCH BOXES

Contains ten DPST toggle switches and one terminal board, completely wired up in a watertight case. All new. **Each \$3.50**

## ANTENNA RELAY UNITS

Contains a Weston RF Meter; Thermo-couple, sensitive relay and a 50 Mmfid. 5000 volt vacuum condenser. All in case. Excellent condition **Each \$2.50**

## TUBES

8025	\$4.95	4E27	\$12.95
3FP7	1.95	8020	2.95
5FP7	1.25	6X17	1.25
5BP4	2.50	6V6	1.25
6SC7	1.00	6E5	.75
6SJ7	1.00	6U5	.75
12SR7	.90	6BR	.75
6AG5	1.50	8A1	1.25
6AK5	1.75	6SH7	.50
6AC7	1.50	7193	.50
		6SN7	1.75

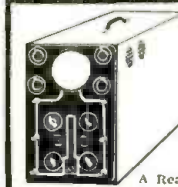

## 3" TRIUMPH OSCILLOGRAPH

Complete Test Scope, with built-in Wobulator, so as to be used on TV or FM servicing. Operates from 110 Volt, 60 Cy. A.C. Limited Supply. All these units have been carefully checked and are in excellent condition. **A Real Buy. SPECIAL \$34.95 Ea.**

# STANDARD SURPLUS

1230 Market St., San Francisco 3, Cal. Telephone HEMlock 1-3106

# SPECIAL CASH WITH ORDER PRICES

## COMMAND AND/OR ARCS TRANSMITTERS AND RECEIVERS

RC-442 Antenna Relay, Less Vac. Cond.	USED NEW
RC-450 3 Receiver Control	1.99
3-0 MC Receiver	5.95 \$11.95
0-1 Receiver	6.95 9.95
Triple Receiver Rack	\$1.95
V.H.F. ARC Transmitter or Receiver, Complete w/ tubes	17.95
1-3 MC Transmitter with tubes	14.95
4-3 MC Transmitter with tubes	3.95
3-3 MC Transmitter with tubes	3.95
1 MC Transmitter with tubes	5.95 19.95
3-4 MC Transmitter with tubes	18.95
28V Receiver Command Dynamotors	\$0.97

### MODULATORS

RC-430 with Tubes, less 100	2.95
MD-7 ARC Plate Modulator	7.95
MD-7 Modulator Dynamotor, 28V	3.95

### USED NEW

RC-442 Receiver—w/ tubes	\$12.95
RC-442 Receiver—w/ tubes	24.95
MC-260 Compass Receiver	24.95 \$39.50
RC-1206 Receiver 200-400 kc	5.95 9.95
RC-357 Marker Beacon Rec. W.O. Tubes	4.95
RC-357 w/o tubes, used—\$6.95. w/ tubes	19.95

RC-375 Trans. 100 Watt Voice, CW, MCW, freq. range 900 kc to 12 mc, uses Plug-in Tuning Units listed complete with tubes, less Tuning Units	\$18.95 \$24.95
TUNING UNITS for RC-375 or 191 Trans.	
TT-1 4,000-500 kc	\$2.49
TT-2 8,000-1,000 kc	2.49
TT-3 7,700-10,000	2.49
TT-4 10,000-12,000	2.49
TT-5 22 & TT-26 200-500 kc	each 4.50
FT-151 Shock Mounting for RC-375 or 191	2.95
RC-306 Antenna Loading	1.95

GP-7 NAVY TRANSMITTER: 100 watt master os. Can use on any freq. from 300,000 kc. by using proper plug in. With 1 tuning unit \$13.33

### LOOP ANTENNAS

DL-1 Has 2 tube amplifier	New \$25.95
MM-20 L	New 7.95
LL-21 A	New 9.95

PLS Filters—A's, B's, C's	New \$ 1.95
PLS Filters	New 79
Hand Keys—J-38	New 79
TSC TRANSMITTER & RECEIVER with 12V Power Supply and Cables, Good—used	179.50
Helmman Circuit Breakers, 115 V, 20 amp	1.39
Prop Pitch Motors	New 13.95
Prop Pitch Motors—with Transformer	New 19.95
Prop Pitch Transformer, only	New 6.95
RT-7APN-1 Transceiver, tubes & dyn. Used	9.95

### TRANSFORMERS

3200V 300 ma NCT—\$8.95	Pair \$15.95
12V 24V 2 am 110V primary	2.95

ARC-4 2 Meter Transceiver, tubes—good, used	\$39.50
2-2 Meter Transmitter with tubes—good, used	\$9.50
RC-434 Control, Used	\$1.95
Code Practice Tapes for TG-10 11 rolls	New 7.95
RC-906 Absorption Type Freq. Meter, Range 150-225 mc, 0-500 DC Microm. Used—\$11.50	New 14.95
Model Phones K-L 8's, Used \$15.95 pr. New \$34.50 pr.	

### DYNAMOTORS

DE-103 NEW, ORIGINAL CASE.	\$29.95
DE-103 NEW, Less Base—Dynamotor	19.95
DM-32A Input 28V, Output 250 DC amps	Used 1.95
DA-1A Input 28V @ 1.6 amps, Output 230 DC @ 1 amp	Used 5.95
PE-3 23V @ 20 amps, output 1000V @ 20 amps	New 5.95
PE-7 14V @ 40 amps output 1000V @ 70 amps	New 15.95
SPEC 27V @ 400V @ 7.50 mil 750V 350 mil	New 12.95
DL-94 or SCR—529 24V Used.	\$5.95, New 14.95
DL-94 Dynamotor only	4.95
DM-34 12V @ 2.8 amps, Output 220V @ 100 amps	New 5.95
SPEC 3V @ 450V output @ 80 ma. New 5.50	
SPEC 12V @ 320V output @ 80 ma. New 4.95	
SPEC 3V @ 250V output @ 80 ma. New 5.95	
SPEC 12V @ 440V output @ 200 ma. New 8.95	
ALC-1 DY-9/ALC-1	Used 14.50
ARC-1 Dy-10 12V	Special 9.50

GN-1 FM Receiver 20 to 30 mc FM Receiver with tubes—used	\$29.95
RC-421B Antenna Reel Ass. Less wire	New \$39.50
	9.95

### OIL CONDENSERS

#### Standard Makes—New

2 mfd 600V	\$0.49	10 mfd 600V	\$ 1.95
4 mfd 600V	1.39	2 mfd 2500V	2.95
1 mfd 1000V	.89	2 mfd 4000V	3.95
2 mfd 4000V	7.95	2 mfd 5000V	8.95
1 mfd 10000V	24.95	1 mfd 7500V	19.95

T-30 throat Mikes	3 for \$0.50
CD-507 Head set Extension Cord	.89

### HEAD SETS

HS-20 New—\$1.69	HS-33 Used—\$1.19
HS-23	Used—\$1.19; New—2.95
Matching Transformer for HS-33	.69

RC-348 Mounting Base	\$2.00
RC-349 Coax Cable, 1/2 ohms, 100 foot	.08
MIKE CHEST SET "F-1" 1" latton	New 2.95

CASH WITH ORDER. PRICES SUBJECT TO CHANGE WITHOUT NOTICE. MANY MORE ITEMS. California Orders Please Include 3 1/2% Sales Tax

## SAM'S SURPLUS

1308 BOND ST. LOS ANGELES 15, CALIF.

vision contractor and service dealer as an important factor in the industry. Frank Moch, the untiring and ruggedly persistent president of TISA finally broke through one of the barriers recently and was invited to sit in on a meeting of the RTMA with the National Better Business Bureau for a discussion of television consumer problems.

Although no official releases were issued concerning the subjects that were discussed at these meetings it is reliably reported that the BBB's are particularly incensed over the "in-warranty" parts debacle. This certainly should not have surprised anyone at this meeting for it has been pointed out repeatedly by TISA, TCA, and other service contract organizations—men who know from daily experience the real causes of the festering sores of consumer complaints—that the "in warranty" parts racket would sooner or later get the entire television industry into a mess of sizzling hot water.

When we see men in industry blandly ignore the glaring faults of their own segment of activity we find it easy to recapture the picture of "Honest" Jake Malik and his ingenious statement to the UN delegates that, "Russians are free people; they can go where they want and work where they want. Everybody knows that."

## International Short-Wave

(Continued from page 63)

"We do not broadcast programs in English," Mr. Gallo explains, "but make identification in that language, usually every 15 minutes. All reports—that is, correct ones—are verified by letter. IRC's are not good in this country; therefore, we are asking DX-ers to remit a 10-cent U.S. postage stamp for return reply—or 10 cents in U.S. coin."

Our best wishes go to both ELBC and YNDG for long and successful careers in the field of short-wave broadcasting!

### What's Ahead?

Donald Fox, Washington, D.C., has supplied us with these interesting excerpts from an article by T. W. Bennington in "London Calling" (organ of the British Broadcasting Corporation) regarding reception conditions on short-waves used by the BBC in its overseas services, and forecasting that decreasing sunspot activity in 1951 will mean, in general, more and more use of the longer of the short-wave bands. In part, Mr. Bennington, wrote:

"Short waves travel to their destination by way of the reflecting layers of air in the upper atmosphere—the ionosphere, as it is called. The ionosphere is produced by the sun, and its condition—and hence the conditions for transmission of the short waves—varies with the sun's activity.

"This activity varies constantly, and is indicated by the sunspots, which wax and wane over a period lasting,

# TUBES?

We have 'em in stock now! (Subject to sale and some price variations.)

## FULLY GUARANTEED

7JP4	\$18.50	6CD6G	\$ 3.00
10BP4	24.00	6J5GT	2.75
12LP4A	25.00	6J6	.20
14BP4A	26.25	6K6GT	1.10
16HP4A	33.00	6S4	1.10
16RP4A	33.00	6SA7GT	1.25
17BP4A	34.00	6SG7	1.00
20CP4A	57.50	6SK7GT	1.10
0Z4/0Z4G	.90	6SN7GT	2.00
1A7GT	1.00	6SQ7GT	1.25
1B3GT	1.65	6T8	1.50
1R5	1.40	6T8	1.50
1U4	1.00	6V6GT	1.10
1X2/1X2	1.60	6W4GT	1.00
2B7	1.00	6W6GT	1.50
3Q4	1.10	6X4	.90
5T4	1.95	6V6G	.95
5U4G	1.20	7C5	.90
5V4G	1.50	7C6	.90
6AC7	1.60	7C7	.90
6AG5	1.70	12A7	1.95
6AG7	1.95	12A7U	1.40
6AH6	2.20	12BA6	1.10
6AK5	2.00	12BE6	1.10
6AL5	1.00	12BH7	1.80
6AQ5	1.10	12SK7	.99
6AU5GT	1.75	12SN7GT	1.50
6AU6	1.25	19T8	2.25
6AV6	1.05	25L6GT	.95
6BA6	1.25	35C5	1.00
6BC5	1.40	35L6GT	1.10
6BE6	1.35	35Z5GT	.90
6BF5	1.65	50A5	1.30
6BQ6GT	1.90	50C5	1.00
6BY5G	2.00	50L6GT	1.10
		1280	1.10
6CB6	1.45	807	1.60

OTHER S'PL PURPOSE, RADIO AND XMTG. TYPES IN STOCK—WRITE

TERMS: 25% with order. Balance C.O.D. Send remittance in full and save C.D. charges. M'dse F.O.B. N. Y. C.

Telephone: Rector 2-2563

**BARRY ELECTRONICS CORP.**  
136 Liberty Street, New York 6, N. Y.



Be Sure to Stop at...

**Booth 121**  
**OFFICIAL TRADE SHOW**  
**Stevens Hotel, Chicago**  
**MAY 21-22-23**



Sell Extension Speakers, when you install TV in Bars, Cocktail Lounges, Etc.

Lowell Speaker Baffles assure UNIFORM SOUND REPRODUCTION IN ALL DIRECTIONS, give excellent low level response, have "floating conical action." Lowell Baffles are available in all sizes from 6" thru 15", in AL Models (shown above) for low ceilings, and in BL Models for normal ceilings. For complete details and prices, write for new catalog covering complete line of Lowell Baffles, for all sound installations.

**LOWELL METAL PRODUCTS CORPORATION**

1531 Branch St., St. Louis 7, Missouri

on the average, about 11 years. Thus, the sunspot activity increases towards a maximum and then decreases towards a minimum again, which variation is the well-known sunspot cycle.

"When sunspot activity is at a maximum, the condition of the ionosphere is such that the shortest of the short waves are best transmitted; when the minimum approaches, the shorter short waves fail, and more and more use of the longer short waves must be made.

"The sunspot activity reached its last maximum in 1947, and since then it has been decreasing, though it has done so in a far from regular manner. Up to the end of 1949, in fact, the downward trend was only faintly apparent, but during 1950, and particularly during the latter half of the year, the general decrease in sunspot activity became much more rapid . . .

"How, then, is the situation likely to change during 1951? Well, no one has yet succeeded in accurately forecasting the sunspot-cycle changes for very long ahead, so we should, perhaps, be a little diffident in making precise statements about things which are entirely dependent on them—like the useful wavelengths for short-wave broadcasting.

"But of one thing we can be fairly sure: the sunspot activity will go on decreasing—or, at least, will not show any very large subsidiary increase—until it has reached a value something like that which prevailed in 1944, the year of the last minimum.

"Whether it will continue to decrease at its present rate is very difficult to say, but the chances are that it will not: that is to say, the activity should soon begin to decrease more slowly. So the ionospheric critical frequencies, following the sunspot number, may, during 1951, continue to decrease, but, after a time, begin to do so at a decreased rate.

"During 1951, therefore, the wavelengths of most use for short-wave broadcasting are likely to become even longer than they are at present, and account will have to be taken of this. Of course, there will be the usual seasonal changes in the transmitting schedule, but, over and above these, there will be a general tendency—forced upon us by the changing conditions—to make more use of longer wavelengths.

"During the summer it is probable that 11 meters will fail in southerly directions, and that 13 meters will be of less utility than at present. For daytime broadcasting, more use will therefore have to be made of the 16-meter and 19-meter bands. But it is at night-time that things are likely to become serious. During the summer, all should be well, the 25-meter and 31-meter bands being usable over many circuits. But next winter only 42 and 49 meters are likely to be usable for nearly all services.

"And, unfortunately, as increased use of these bands will be made by nearly all the world's broadcasting

May, 1951

**Valuable guides for television technicians**

CHECK THE ONES THAT CAN HELP YOU MOST AND SEE THEM ON APPROVAL

*Just published!*

**MOVIES FOR TV**



A practical how-to-do-it guide for technician and program director alike.

This complete, practical book gives you all the information you need to choose the best equipment, operate it most efficiently, and make the most effective use of movies on TV programs. It explains the operation of all leading makes of cameras, projectors, sound and kinescope recording equipment, different types of lenses, etc., giving the advantages, disadvantages, and relative costs of each. It shows what may go wrong and how to avoid trouble, what type of picture is good on television and what is not, how to light movies for best TV reception, how to insure good shots on location, combine live scenes with movies, produce special effects, titles, newsreels, different types of commercials, and much else that will be of utmost practical aid to station personnel and program planners. *By J. H. Battison.*

**TELEVISION & FM ANTENNA GUIDE**



How to get the most out of the antenna system at any location.

This excellent handbook will save you much testing and readjusting and insure the best reception from any antenna system. It gives you the characteristics, dimensions, advantages and disadvantages of all VHF and UHF antennas and allied equipment, including heretofore unpublished information on new types recently tested by the authors. It tells how to determine the right type of antenna for a specific location, locate space loops, determine signal strength, etc.; how to mount various types of antennas on different kinds of roofs or window sills; how to minimize noise and avoid standing waves in transmission lines, and all other installation procedures. Handy tables give comparative data, and there is full, clear instruction in all fundamental antenna principles. *By Noll & Mandl.*

*Outstandingly helpful references*

**TELEVISION FOR RADIOMEN**



The outstanding book on television for servicemen. Explains in clear, non-mathematical terms the operating principles and function of every part and circuit in today's TV receivers, and the chief principles of transmission. Complete, practical instruction in installation and alignment procedures, testing equipment and how to use it, adjustment, and trouble-shooting. *By E. M. Noll.*

**RADIO & TELEVISION MATHEMATICS**



This unique handbook of 721 problems and solutions shows you what formulas to use, what numerical values to substitute, and each step in solving any problem you are likely to encounter in radio, television, or industrial electronics. Conveniently arranged and fully indexed for quick reference. *By Bernhard Fischer.*

**USE THIS COUPON**  
to get FREE examination copies. If you're not fully satisfied, you may return them without further charge.

The Macmillan Company, 60 Fifth Avenue, New York 11

Movies for TV \$4.65      Please send me the books checked. I will either remit in full or return the books in 10 days.

Television & FM Antenna Guide. \$5.50

Television for Radiomen \$7.50      Signed .....

Radio & Television Mathematics \$6.00      Address ..... N

# PLATT SAVES YOU MORE



... so why not order by mail or visit PLATT'S BIG RETAIL STORE at 489 BROOME ST., NEW YORK CITY.



## HEADSETS

HS-33 low impedance with cord and plug, used, fine condition.....	\$1.89
HS-23 high impedance, BRAND NEW with ear pads.....	3.25
HS-33 low impedance, BRAND NEW with ear pads, cord and plug.....	4.00
TH-37A—1200 ohms with dual plugs.....	2.95
HS-30 with ear plugs, low impedance, used, good condition.....	.89

## BEACON RECEIVER BC-438

Manufactured by Detroit

Frequency Range—200 KC to 400 KC, IF Frequency—142.5 KC Receiver Sensitivity—3 Microvolts for 10 Milliwatts output. Output Impedance—300 Ohms and 4000 Ohms to be selected internally. Power Output—150 Milliwatts. Volume Control—RF Gain Control. Power Supply—24-28 Volts Aeroplane Battery. Current—1.0 Amperes, 6 tubes.



**\$10.95**

BRAND NEW—ONLY



## TS-268/U CRYSTAL RECTIFIER TEST SET

Brand New—complete with set of spare parts.....

**\$39.95**



## SCR-27N COMMAND and ARC-5 EQUIPMENT RECEIVERS

	USED	NEW
BC-453—190 to 550 KC.....	\$12.95	
BC-474—3 to 6 MC.....	7.95	
BC-455—6 to 9 MC.....	6.95	\$11.95
RC-25—ARC 5—100-550 KC.....		21.95

## TRANSMITTERS

RC-157—4 to 5.3 MC.....	5.95
RC-458—5.3 to 7 MC.....	5.95
RC-646—3 to 4 MC.....	14.95
T-19—ARC 5—3 to 4 MC.....	24.95
RC-459—7 to 9.1 MC.....	12.95
T-22—ARC 5—5 to 9.1 MC.....	12.95

## ADDITIONAL EQUIPMENT

RC-456 Modulator.....	2.25	3.25
RC-450 Control Box (3 Receiver).....	.98	1.95
RC-451 Control Box (Transmitter).....	.89	1.49
RC-442 Relay Unit (ANT).....	1.95	2.95
Plugs: PL-147, 148, 151, 152, 153, 154, 156—EACH.....	.75	
Flexible Shafting with gear to fit Receivers.....		1.69
3 Receiver Rack.....	2.25	
2 Transmitter Rack.....	1.69	



## FIELD TELEPHONES

Army surplus, completely reconditioned and electrically tested, using 2 flashlight cells and a pair of interconnecting wires. GUARANTEED—like new.

**\$15.95 ONLY**



## BC-223 TRANSMITTER

A 30 watt Transmitter. Ideal for ship-to-shore or Ham Rig. Crystal or MU control on four pre-selected channels. 2000 to 5250 KC. Use of 3 plug-in coils, five tubes: 2—801 and 3—46, and TU 17-18-25 tuning units.

TRANSMITTER.....	\$25.95
TUBES.....	3.75
TUNING UNITS.....	2.25 ea.
PE-125 VIBRATOR POWER SUPPLY FOR RC-223.....	\$18.95

**WRITE FOR OUR FREE CIRCULAR!**

## MINIMUM ORDER \$2.00

Immediate Delivery—Send 25% deposit on C.O.D. orders. All shipments F.O.B., N.Y.C. (N.Y.C. residents add sales tax to your remittance.)

## PLATT ELECTRONICS CORP.

Dept. A, 489 Broome St., N. Y. 13, N. Y.  
PHONES: WO 4-0827 and WO 4-0828

services, the congestion in them is likely to be severe. A considerable amount of interference is, therefore, to be expected.

"Summing up," says Mr. Bennington, "we may say that during 1951 sunspot activity will most likely go on decreasing, and, as a result, the shorter wavelengths now in use, both by day and night, will become of less utility. During the summer, the situation is not likely to become severe, but, during the winter, and particularly at night, the crowding of stations into the only usable bands of 42 and 49 meters is likely to cause some increase in mutual interference."

## This Month's Schedules

(NOTE: During May, some stations may change to Summer Time; in such cases, you may find schedules one hour earlier than listed herein.—KRB)

**Albania**—Radio Korce is now audible on 7.950 weekdays 0100-0200, Sundays 0200-0300; daily 0800-0900, 1145-1430; output is 100 watts; sometimes the frequency is altered and the modulation is still very poor. (Radio Sweden)

**Algeria**—Radio Algerie has two new short-wave transmitters under construction, according to a recent ISWL Bulletin from London.

**Angola**—Ridgeway, South Africa, reports Nova Lisboa on 5.093, good level at 1545; also heard well on 11.925 sometimes around 0600 with Portuguese music.

## G.I. FREE SCHOOLING DEADLINE NEARS

VETERANS of World War II are reminded that the educational feature of the G.I. Bill expires for most veterans on July 25, 1951 and that those who plan to enter school or enroll for correspondence school training must act quickly.

The great majority of such veterans must start their training and actually be enrolled in the school of their choice by July 25th or forfeit their educational benefits. Veterans discharged after July 25, 1947 have four years from their discharge date to start their training.

According to information received from the Veterans Administration, a veteran must be in training on July 25th unless he has temporarily interrupted his course for summer vacation or for other reason beyond his control.

Once he completes or discontinues his course of G.I. Bill training after the deadline, he may not start another course. Also, he must meet the following two post-deadline requirements.

1. He will be expected to pursue his training "continuously until completion except for conditions which normally would cause interruption by any student."

2. He may change his education objective "only while in training and then for reasons satisfactory to the Administrator." Public Law 610, which permits a veteran to make a first change of general fields of study merely by applying for it, will not be in effect after the cut-off date.

Special consideration will be given to four categories of veteran-trainees who,

**Argentina**—LRT, 11.840, Tucuman, noted 2230 and signing off in Spanish 2250. (Guzman, Cuba)

**Australia**—VLX, 4.8975, Perth, noted 1040 and signing off 1100 with "God Save the King." (Pearce, England) Correct call is VLX and correct frequency is 4.8975. (Hutchins, Radio Australia) VLM, 4.9175, is heard with music and ending test at 1457; time pips at 1500, then news from the ABC, local news, weather, early morning market reports, then music. (Pearce, England) This is correct frequency and correct call. (Hutchins, Radio Australia) Both these outlets are heard fair-to-good mornings here in West Virginia.

VL13, 9.500, Sydney, N.S.W., noted with weak signal after XEWW, Mexico City, leaves that channel 0110. (Grove, Ill.)

Reports to Inland Stations in Australia should be addressed to the Australian Broadcasting Commission in the city from which the station operates. Radio Australia recently has been behind in answering hundreds of reports, but hopes to "catch up" soon. (Hutchins, Radio Australia)

**Austria**—Blue Danube Network, 9.617, Salzburg, noted 0600 with news resumé; sports headlines at 0605; noted another day 0500 with news headlines followed by recordings.

**Azores**—CSKA, 4.845, noted daily around 1700; announces "Emissora Regional dos Acores" frequently; easy to identify. (McWalter, Scotland)

for reasons beyond their control, either may not be able to resume their training by July 25, 1951, or may not be in a position to remain in continuous training afterwards.

The categories are: 1. Veterans who have started G.I. Bill studies and interrupted them to go back into active military or naval service; 2. Veterans who complete premedical and pre dental G. I. Bill schooling and can't get into a medical or dental school by deadline time; 3. Teachers who spend their summers taking training leading to a degree; and 4. Those who complete G.I. Bill undergraduate courses and intend to go ahead with graduate training which would start after the deadline date.

The Veterans Administration emphasizes that most veterans may not receive training after July 25, 1956, the wind-up date of the program. The only exception to the final date are those who enlisted or re-enlisted between October 6, 1945 and October 5, 1946 under the Armed Forces Voluntary Recruitment Act. Those veterans have four years from the end of their enlistment or re-enlistment period in which to begin G.I. Bill training, and nine years from the end of that period in which to finish.

Veterans who are in doubt about their status under the educational feature of the G.I. Bill should contact their local Veterans Administration office immediately so that all of the formalities can be completed before the July 25, 1951 deadline.

—30—





## Ungar's Little Angels

DO A HEAVENLY SOLDERING JOB

Pick any job and you'll find a pip of a tip to use with the trim, slim Ungar Pencil. Any of the 8 Ungar Angels interchange in the No. 776 Handle to make a honey of a tool that does work faster and better than larger, heavier irons. Whatever your problem, you'll bless the day you discovered these saintly soldering cherubs!

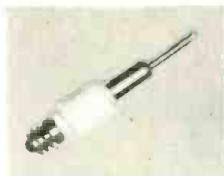

No. 538 1/8" CHISEL TIP, 20 Watts  
For Light Duty Work. Especially recommended for Printed Circuits. Very useful for small joints and hard-to-reach points on radio and TV, electronic assemblies, aircraft instruments, bearing and assembly and repair.

Write for Catalog No. 400

**Ungar** ELECTRIC TOOLS, INC., Los Angeles 54, Calif.

OPENING  
A NEW  
MARKET!

**Spico**

INDOOR  
ALL-CHANNEL  
TELEVISION & FM ANTENNAS

REVOLUTIONARY NEW  
*Super-Phantom*

MODEL TV-503

Provides BETTER reception over GREATER distances than any other indoor TV Antenna! Exhaustive tests prove that Super-Phantom sharply reduces, and in many instances completely eliminates ghosts and interferences. Note these features:

- **ADJUST-A-KNOB** fingertip tuning control adjusts antenna to desired channel, for peak signal.
- **OPTIMUM MATCHING STUB** permits precision impedance matching of antenna to every type of set.
- **Telescope Plated Brass Dipoles** for greatly increased gain.

Model TV-503 Super-Phantom... List Price \$7.95

PATENT  
PENDING

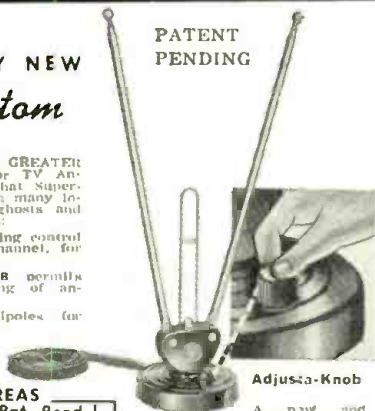

Adjust-a-Knob

And for LOCAL AREAS

"Spico" Phantom-Tenna (Pat. Pend.)

Similar to Super-Phantom described above, except dipoles are fixed length non-telescoping, only 17 1/2" long. Phantom-Tenna is equipped with **ADJUST-A-KNOB** and **MATCHING STUB** described above. Adjust-a-Knob eliminates need to telescope adjustment. Plated brass tubing. Model TV-501 Phantom-Tenna... List Price \$6.95

• "Spico" Masterette

Model TV-6 (Pat. Pend.)  
Conventional portable indoor telescopic TV antenna for normal reception areas, neat, well-built, priced remarkably low! Model TV-6 Masterette... List Price \$4.95

• "Spico" Tenna-Master

Model TV93B (Pat. No. 156379)  
Beautifully designed indoor TV antenna, telescopic dipoles, with exclusive patented **LOCK-NOTCH** VERTICAL ORIENTATION, assures permanent non-skid automatic positioning, eliminates tightening or loosening of dipole elements. Model TV93B Tenna-Master... List Price \$6.95

ALL "Spico" Indoor TV & FM Antennas feature Bakelite Housing and Base, concealed wiring, plated brass rods, 300-ohm connecting lead. Engineer-approved and sold by national known TV set Mfrs. Distributed thru jobbers only.

A new and more efficient method of adjusting antenna to each individual channel by "finger-tip" tuning control, for absolutely peak television signal.  
... List Price \$6.95

AT THE  
PARTS SHOW

You are invited to see our outstanding "Spico" line on display at our Booth #225 and on actual demonstration in Display Room #512-A.  
Stevens Hotel  
Chicago  
May 21-23

**SPIRLING PRODUCTS CO., INC.** 62 GRAND ST., N.Y. 13, N.Y.

"One of America's Leading Manufacturers of TV & FM Indoor Antennas"



SOMETHING

**SPECIAL**

FROM

**WALSCO**



**WALSCO LUBRICATOR**  
Designed to reach the many cramped and hidden points in radio, TV sets and record changers. Ideal for applying light greases and oils. Syringe-type plunger releases desired amount of lubricant.  
ONLY 48c DEALERS NET.\*

**WALSCO CONTACTENE INJECTOR**

Permits application of contact chemicals to volume controls and switches without unsoldering connections or taking controls apart. Finest surgical-grade needle and oil-resistant, neoprene bulb.  
ONLY 45c DEALERS NET.\*

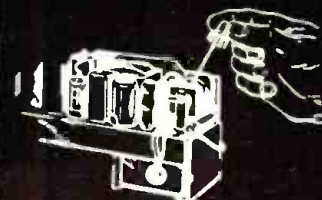

... AND SPECIFY FAMOUS QUALITY WALSCO RADIO CHEMICALS

CONTACTENE  
WALSCOLUB "B"

NO-OX  
TUNERLUB

**WALSCO**

**Walter L. Schott Co.**

Los Angeles 18, California  
Chicago 6, Illinois

\* SOLD EXCLUSIVELY THROUGH  
JOBBERS EVERYWHERE. PRICES  
SLIGHTLY HIGHER IN CANADA.

# Lowest prices!

## C-1 AUTOPILOT SERVO UNIT—

Use to rotate beam antenna, actuate boat rudder control, etc. Contains 24 V. motor, clutch, relays, etc. Reversible. Size overall approx. 10 1/2" x 8 1/2" x 6 1/2". Ideal for light hoisting. Make your own garage door opener. Removed from aircraft.



PRICE \$8.95



## BEAM INDICATOR

I-82F Compass Indicator. 0-360°-5 in. dial. 26 v. 400 cy. 8-12 v. 60 cy. Ideal position indicator.

Price \$4.50 each

## Tuning Indicator—"S" Meter

This is the meter you have been waiting for. Weston. 2.5 mil. movement. Illuminated scale. Scale diameter 1 7/8". Brand New. Special at \$3.50.

## Volt-Ammeter

Weston. 0-30 volts DC. Push to read switch. Also 0-60 amp. D-C current scale. With shunt. Special at \$7.95 each. Also available less shunt at \$4.95 each.



## TURBO SUPER CHARGER REGULATOR AMPLIFIER

Used U.S. Air Force; made by Allen. 115 v. 400 cycle input. Brand new and complete \$5.95.

Synchro timing motor—1RPM—115 v 60 cycle. Hansen Mfg. Brand New. . . . \$2.75  
 E-5 Ball bearings—new and packaged. High precision aircraft type. . . . Each \$1.50  
 Rotary switch—Arrow H&H DPST 110 v @ 10 amp.—450 v @ 3 amp. . . . 69c  
 Rotary switch—Arrow H&H DPDT 110 v @ 10 amp.—450 v @ 3 amp. . . . 69c  
 Fuse holder—Buss type HCM. . . . 26c  
 Parwood circle cutters—up to 8" hole. . . . 95c  
 1000 ohm 2w potentiometers—carbon. . . . 39c  
 Heating elements—250 watt 220 v. 17 1/2" by 1" dia. sealed. Oven heating. New. . . \$1.95

## RELAYS

Cutler-Hammer type 6041H30B 12 volts dc 50 amp. contacts. . . . \$2.95  
 6 1/2 vdc DPST low voltage contacts flange mount. . . . 49c  
 G.M. Labs 12942 6-12 vdc make one break one—heavy contacts. . . . 69c  
 G.M. Labs 12849 6-12 vdc DPST. . . . 69c  
 Clare A 15764 150 ohm coil telephone type break three make two. . . . 95c  
 Clare A 7409 3300 ohm coil telephone type SPST. . . . \$1.19

## DYNAMOTORS

G.E. type D-101 input 27 vdc @ 1.5 a Output 285 vdc @ 060 a. . . . \$4.95  
 Weston Electric DM 36 D 28 vdc @ 1.4 a Output 220 vdc @ .080 a. . . . \$5.50  
 Pioneer Gen E. Motor input 12 vdc @ 3-4 a Output 275 vdc @ .110 a & 500 vdc @ .050 a. . . . \$11.95  
 Bendix PE94C input 28 vdc @ 10.5 a Output 300 vdc @ .280 a & 150 vdc @ .010 a and 14.5 vdc @ 5.0 a. . . . \$16.50

## CAPACITORS

2 x .05 mfd oil @ 600 vdc. . . . 29c  
 2 x .1 mfd oil @ 3000 vdc. . . . \$1.00  
 .25 mfd oil @ 2500 vdc. . . . 95c

## TUBES

6SN7. . . . \$1.68 7F7. . . . 89c  
 7Y4. . . . 89c 6H6. . . . 89c  
 7N7. . . . \$1.49 C1B. . . . \$3.95

**TERMS:** 20% cash with order—balance C.O.D. Orders accompanied by payment in full must include sufficient postage, otherwise shipment will be made via Railway Express collect. Minimum order \$2.00.

# Electro Devices

INCORPORATED  
 247 BROADWAY PATERSON, N.J.

*Bechuanaland*—ZNG, 8,242, Mafeking, is noted 1400. (OTC, Belgian Congo, via Grischott, Calif.)

*Belgian Congo*—Leopoldville's 11,650 outlet noted 2030, good level, with *English* announcement.

OTC2, 9,767, is scheduled daily 1100-1830 and 1830-0100; the "Amongst Friends Club" is conducted Tuesday, Friday, Saturday at 1410-1415 for Europe and 2210-2215 for USA-Canada. (Grischott, Calif.)

*Bolivia*—CP38, "The Southern Cross Radio Station," La Paz, on 9,505, sends information to Pearce, England, that it is British-owned, the property of the Canadian Baptist Mission in Bolivia; that it is considering an experimental broadcast in *English* on Friday nights after it closes its regular Spanish broadcasts; relays CP27 on 730 kc.;

input power to the short-wave transmitter is just under 1 kw.; it is an evangelical, non-commercial station, and the QRA is Cajon 8, La Paz, Bolivia.

*Brazil*—PRL7, 9,72, Rio de Janeiro, is coming through well in Scotland around 1500-1600; announces "Radio Nacional." (McWalter) ZYK3, 9,565, has "Brazil Calling" at 1900-1930, at least on week-days; may be earlier on Sundays. ZYP23, 5,045, *Radio Quitandinha*, Petropolis, noted 2000 with music. (Dvorak, Ohio) ZYK3 asks for reports and says will verify with QSL. (Machwart, Michigan) ZYC8, 9,610, *Radio Tamoio*, Rio de Janeiro, signs off 2050. ZYC9, *Radio Tupi*, 15,370, Rio de Janeiro, is heard fair to good 1800-1830 in Portuguese. (Callarman, Oregon)

*Bulgaria* — *Radio Sweden* reminds

## UNIQUE I.F. TURRET BOOSTER DEVELOPED

A UNIQUE i.f. Turret Booster that plugs into the i.f. amplifier of a television receiver and provides an additional stage of intermediate frequency amplification has been developed by Barb City Industries Inc. of De Kalb, Illinois.

To install the new circuit an i.f. amplifier tube in the receiver is removed and the tube thus removed is then placed in the bottom socket of the booster. The booster is then plugged into the empty i.f. socket on the receiver. A slight adjustment of the i.f. coil on the booster and of the following stage may be required to give the receiver the proper i.f. response. This is necessitated by the increased circuit capacity due to the additional lead length.

The circuit is an ordinary i.f. stage of amplification inserted in series with the plate lead of the i.f. stage of the receiver. See Fig. 2. Thus the output of the tube which has been removed goes to the input of the turret i.f. stage mounted above and the output of the turret i.f. stage is then fed back into the receiver socket.

Plate and screen voltages for the turret tube are taken from the screen connection of the bottom tube. Most re-

ceivers use a 1000 ohm resistor in the screen circuit from the "B plus" which is capable of carrying ample current to operate the turret tube. The filaments are in parallel, therefore the booster should be used only in receivers having parallel filament circuits. Nearly all sets having filament transformers will allow the additional .3 ampere filament current drawn which is all the current that is required when using the Turret Booster.

The new unit does not require tuning for each station selected because it operates on the intermediate frequency; it can be removed or installed without rewiring the receiver; it operates automatically when the receiver is turned on; and it increases the video output an estimated 15 to 20 per cent in most receivers.

-30-

Fig. 1. Over-all view of Turret Booster.



Fig. 2. Complete circuit diagram of new unit.

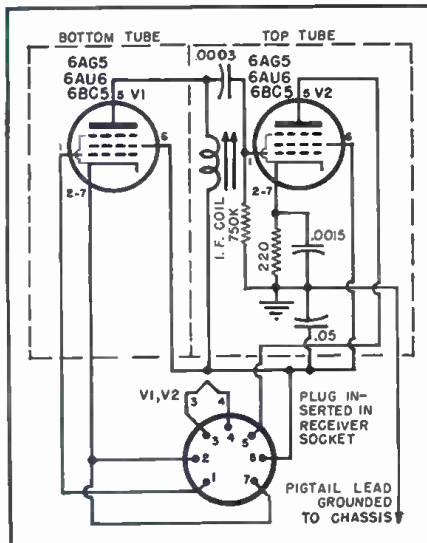

that *Radio Sofia III*, 7.671, broadcasts *English* programs daily 0130-0145, 1500-1529, 1615-1630.

**Canada**—Current schedules of the CBC's International Service are listed — *European Service* — 0850-1130, CKNC, CKCX; 1130-1545, CKNC, CKCS; 1545-1600, CKCS; 1600-1645, CKCS, CKLO; 1645-1700, CKLO; 1700-1730, CKLO, CKRZ; 1730-1745, CKLO, and 1745-1830, CHOL, CKLO. *Australasian Service*—2330-0005 (except Sat., Sun.), commentaries from the United Nations, CKLX, CHOL; 0340-0450 (Sun. and Wed. only), CHOL, CKLO. *Caribbean and Latin American Service* — 1850-1630, CKCX, CKRA, and 2130-2235, CKCS, CKRA; *English* 2100-2130. Stations are CKNC, 17.82; CKCS, 15.32; CKCX, 15.19; CKLX, 15.09; CKRA, 11.76; CHOL, 9.63; CKRZ 6.06.

CBNX, 5.970. St. John's, Newfoundland, has been heard 1830-1900 as the band came in and before HI4T, Dominican Republic, took over on the channel; was very weak and had some QRM on the low side. (Lane, South Dakota)

On Saturdays 1615-1630, CHNX, 6.130, has Hawaiian program. (Bellington, N.Y.) This one noted signing off 2310 and asking for reports to P.O. Box 400, Halifax, Nova Scotia, Canada. (Fox, D.C.)

**Cape Verde Islands**—CR4AA, 5.895V, Praia, noted 1600-1630. (Lindahl, Calif.) Pearce, England, says this one appears to be moving about; he noted it recently on about 5.930 at 1530 sign-on, then news in Portuguese at 1535, followed by light music.

**Ceylon**—*Radio Ceylon*, 15.12. noted opening its Commercial Service 2045 and at 2100 with BBC news relay from London. (Ferguson, N.C.) Is heard mornings on approximately 11.975. Noted by Bromley, Ontario, on 9.52 with weak signal 2010; usually signs off 2030 on this channel.

**Chile** — CE1190, Valparaiso, noted with music around 1930-2000 or later. (Russell, Calif.) Verified in 11 months from Compania Chilena Comunicaciones S.A., Casilla 37-V, Valparaiso, Chile; slogan is "La Voz de Chile para toda America." (Callarman, Oregon) CE1174, 11.740, Valparaiso, noted signing off 2250. (Guzman, Cuba) CE622, 6.220, good usually around 2000-2200, then fades. (Lane, South Dakota) CE1180, 12.000, noted 2030. (Machwart, Michigan)

**China** — Radio Peking, 11.685 and 15.060V, still carries news 0835; also noted evenings irregularly around 1800-2100 in Chinese. Cushen, N.Z., says prisoner-of-war broadcasts are daily at 0450 on these channels, reports *Radio Australia*.

**Colombia**—HJDE, 6.145, blasts in rightly in South Dakota to approximately 2330 sign-off. (Lane) HJAP, 9.890, Cartagena, noted recently with fine signal 2000-2200. (Saylor, Va.) HJKE, 4.835, heard fair at 2345; HJEX, 6.054, Cali, noted with good level 2200; HJKD, 6.000, *Emisoras Nuevo Mundo*, Bogota, heard well 2300,

May, 1951

# the world's toughest transformers

wear these exclusive one-piece drawn-steel cases

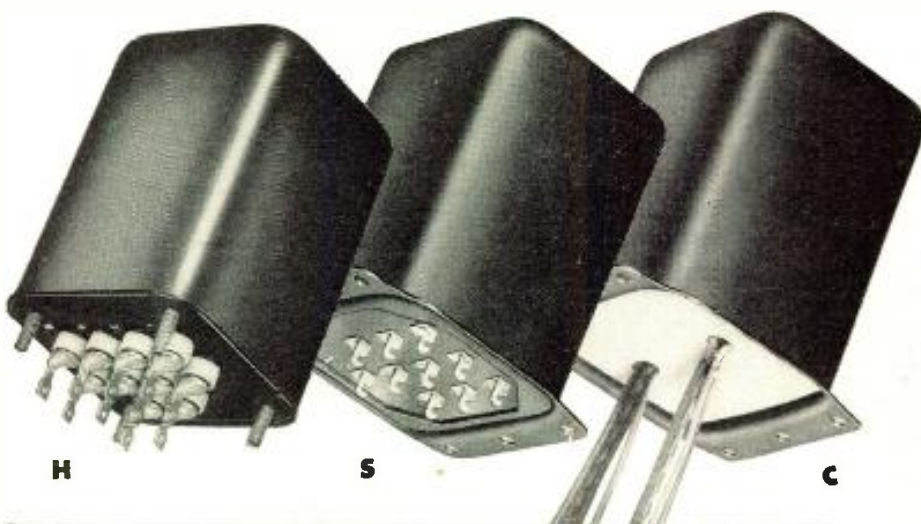

**THE ONLY COMPLETE\*, VERSATILE\*\* LINE WITH TOUGH SEALED-IN-STEEL CONSTRUCTION**

When tougher transformers are made, CHICAGO makes them—in rugged, streamlined drawn-steel cases that provide the fullest enclosure and protection, that look well with other modern electronic components and enhance the appearance of the equipment. The exclusive CHICAGO one-piece drawn-steel case (no seams or spot welds) is the strongest, toughest type of mechanical construction. Further, the one-piece design provides a continuous electrical and magnetic path which means better electrostatic and magnetic shielding. Seamless construction assures maximum protection against adverse atmospheric conditions—means longer, more dependable transformer life.

Whether your transformers must pass the most rigid MIL-T-27 specifications and meet ASEA Type Approval or are intended simply for average, normal applications, it's wise to choose CHICAGO "Sealed-in-Steel" Transformers (the world's toughest) for that extra margin of dependability under all operating conditions.

**\*COMPLETE.** There's a CHICAGO "Sealed-in-Steel" unit for every application: Power, Bias, Filament, Filter Reactor, Audio, MIL-T-27, Stepdown, Isolation—all in one-piece, drawn-steel cases.

**\*\*VERSATILE.** Available in 3 constructions to meet most requirements—a type for every application:

**H-Type.** Steel base cover is deep-seal soldered into case. Terminals hermetically sealed. Ceramic bushings. Stud-mounted unit. Meets all MIL-T-27 specs; has ASEA Type Approval.

**S-Type.** Steel base cover fitted with phenolic terminal board. Convenient numbered solder lug terminals. Flange-mounted unit.

**C-Type.** With 10" color-coded stripped and tinned leads brought out through fibre board base cover. Flange-mounted unit.



**SEND FOR "NEW EQUIPMENT" TRANSFORMER CATALOG**

Have the full details at your fingertips on CHICAGO'S New Equipment Line—covering "Sealed-in-Steel" transformers designed for every application and geared to today's circuit requirements. Write for your copy of this important catalog today, or get it from your electronic parts distributor.



# ATLAS

## Built to take it!



ATLAS DR PROJECTORS, non resonant, uniform response, sturdy, storm proof, compact, demountable.

Regardless of the application Atlas Sound speakers are built to "take it." In the Armed Forces . . . Industrial plants . . . public gatherings . . . under any climatical conditions, Atlas Sound speakers stand up.

Over twenty years' experience in the manufacture of sound equipment goes into every Atlas product. Years of diligent research in Electro Acoustics and constant experimentation in mechanical developments guarantees quality, complete and lasting satisfaction.



ATLAS PAGING AND TALK BACK SPEAKERS with ATLAS "Alnico-V-Plus" driver unit. A medium size speaker ruggedly constructed 12 watt input power.



Dual speaker excellent for industrial and talk back applications, simplifies installation in long corridors, hall-ways, etc.



A super efficient sub miniature speaker produces clear intelligible speech at a minimum input power.



ATLAS De-Luxe "Alnico-V-Plus" Driver Units with built in "uni-match" transformers. 30 watt input.



ATLAS "FULL GRIP VELVET ACTION" MICROPHONE STANDS. No slipping - No noise - No rattle - No scratching - No wear.

Write for new No. 551 catalog

### ATLAS SOUND CORP.

1456 - 39th STREET, BROOKLYN 18, N. Y.  
in Canada, Atlas Radio Corp., Ltd., Toronto, Ont.



off 2330; HJWO, 6.270, *Emisoras Colombia*, Bogota, noted 0015, poor level; a new Colombian is heard on approximately 6.220, good signal; *Radio Nacional de Colombia*, is a good signal in Oregon on 4.960, 6.200, but is poor on 11.680, noted evenings. (Callarman)

HJPP, 6.135, Bogota, noted with music 2250 tune-in and at 2300 man announced in Spanish, played Ted Lewis' "Good Night Song," and left the air; good signal in N.Y. (Bellington)

*Costa Rica*—The 11.965 *Radio Athe-nea*, San Jose, is giving TIRS, TIHH as calls. (Stark, Texas) Is heard in Australia and New Zealand around 0730 and in New Zealand to sign-off 2300; relays medium-wave TIRS. (Radio Australia)

TIFC, 9.645, noted 2329 with religious broadcast; TIPG, 9.620, noted 2335-2350. (Machwart, Michigan)

*Cuba*—Havana has been noted lately on measured 9.8624, heard 1000, modulation very poor; music; may be COBL which hasn't been heard on listed 9.833 lately. (Oskay, N.J.) COCQ, 8.825, is heard best in Scotland around 1800. (McWalter) A Cuban was noted recently signing off 0029, with *English* announcement by man; frequency was 6.450. (Bellington, N.Y.) COBH, 11.80, noted 2355 to 0000 sign-off. (Machwart, Michigan) Is good level in Eastern USA day and night.

*Czechoslovakia*—Prague, 11.875, has news 0715-0745; asks for reports. (Pearce, England) Is a good signal here in West Virginia.

The 9.504 channel noted ending *English* at 1730 (starts 1715) in parallel with 6.170; noted on 9.504 with *English* at 1530. (Pearce, England)

*Dominican Republic*—"La Voz Dominicana," 9.735, is now carrying *English* on Monday, Wednesday, Friday 1900-1915. (*World Radio Handbook Bulletin*) Has been heard in *English* 2200-2215 on Wednesdays over the 9.735 channel. (Callarman, Oregon) Heard on a Monday with *English* in progress when tuned 2135; this continued to 2145 on both 5.970 and 9.735; asked for reports. (Bellington, N.Y.)

H18Z, 4.980, Santiago de los Caballeros, noted 2030-2100. (Guzman, Cuba) H11L, 4.950, "La Voz del Tropico," signs on 0610. (Callarman, Oregon) H11J, 6.025, noted 2035-2100 sign-off on one occasion but may have been a special broadcast. (Machwart, Michigan)

*Ecuador*—HC2RL, 6.630, Guayaquil, noted 2100-2200. (Guzman, Cuba)

*Egypt*—SUX, 7.862, Cairo, has fair signal in South Africa, rather bad QRN usually; native music noted 1430; is heard until 1600 most days. (Ridge-way)

*El Salvador*—YSUA, 6.250, San Salvador, has programs with examples of different types of American music at 2330-0000 sign-off; good level in Oregon. (Callarman) San Salvador, 7.270, heard signing off 2302. (Fox, D.C.)

*Fernando Po*—Although it may be some time before the projected 200 kw. transmitters come into use at Fernando Po, I am reliably informed there is a low-powered transmitter operat-

## America's Greatest Buy!

### Plays 10 1/2" Reels!



Complete, for console installation with single or dual track heads.

# \$345<sup>00</sup>

# CONCERTONE

■ The professional quality tape recorder you have been waiting for! NAB standards; triodes throughout; 40-15000 cycles at 15". 40-8000 cycles at 7 1/2". Three motors; flutter less than 0.1%; signal-to-noise better than 50 db. Three heads for simultaneous erase, record, playback. Quick change from single to dual track. Write for booklet.

FISHER RADIO CORPORATION • Distributors • 37 E. 47th St., N. Y.  
MAGNETIC RECORDERS CO., 7120 MELROSE AVE., L. A. 46, CALIF.

# RADIOMEN'S HEADQUARTERS \* WORLD WIDE MAIL ORDER SERVICE!!!

## SAVE HOURS OF HARD WORK

Do the job in minutes with a BUFRAD Socket Hole Punch. Cut clean accurate holes for sockets, plugs, connectors, etc. Cutting holes in radio chassis is as simple as cutting butter with a hot knife with a BUFRAD punch. Just insert the punch in a 1/2" hole and turn with an ordinary wrench. In a minute or less you can complete a job which often takes an hour with the old "drilling, reaming, and filing" method. With BUFRAD punches you can make 13 different sizes of openings from 1/2" to 3/4" diameter.



- 1/2" sizes..... \$2.08
- 1 1/4" sizes..... \$2.42
- 1 1/2" sizes..... 3.10
- 1 3/4" sizes..... 5.95

## SIGNAL GENERATOR

Genuine laboratory-type precision signal generator Manufactured and sold for \$68.00 each in large quantities during the war by Northeastern Engineering Corp., one of the top manufacturers of electronic equipment for the U. S. Govt. Five fundamental bands starting at 50 KC, strong harmonics up to 120 MC. Five step ladder type attenuator as well as potentiometer output control. Regular 1000 cycle audio oscillator using vacuum tube, not a cheap iron sawtooth audio oscillator. Audio output separately available externally. Weight without packing material 16 lbs. which should show what a world of difference exists between this signal generator and the ordinary cheap oscillator used by the average serviceman. Complete with fused plug and coaxial output lead. Super Special \$28.75



## \$6.95 TAKES ALL THREE BIG BARGAINS "E"

- 1. AUDIO AMPLIFIER**—Brand new push-pull output triode amplifiers having 2 of the valuable and scarce 6X4 type audio transformers that sell for over \$10.00 apiece. Near aluminum case, fully enclosed (largest dimension 6 inch) harmonics up to 120 MC. Five step ladder type attenuator as well as potentiometer output control. Regular 1000 cycle audio oscillator using vacuum tube, not a cheap iron sawtooth audio oscillator. Audio output separately available externally. Weight without packing material 16 lbs. which should show what a world of difference exists between this signal generator and the ordinary cheap oscillator used by the average serviceman. Complete with fused plug and coaxial output lead. Super Special \$28.75
- 2. BANDSWITCHING TUNING TURRET** made by Western Electric. Covers 4 bands above 100 MC. All coils wound with #14 silver-plated wire. Complete with tuning condensers and powerful electric driving motor. ONE OF OUR MOST TERRIFIC VALUES—ONLY \$2.95
- 3. CARBON MIKE** with Push-To-Talk Switch and Gold Plated Carbon Lapel Mike. Combination offer on both mikes \$1.75

## Supreme Instruments Corp. Model 562 Audolyzer. A practical system of signal tracing that tells you the trouble quicker. Makes relative gain measurements.

Shows actual gain or loss of a stage, a tube, or a transformer on the built-in vacuum tube voltmeter, which has ranges of 1, 3, 10, 30, 100, 300, 1000 volts, and resistance ranges of 200, 2000, 200 K, 2 meg, and 20 megs. Distortion sources instantly located. Frequency meter in Audolyzer measures unknown frequencies of oscillators or RF coils. Read actual RF signal's frequency on the Audolyzer dial. The Audolyzer is electrically divided into 2 sections, thus it is possible to signal trace using 2 probes, in 2 directions at the same time: from output end, toward antenna, and from antenna end, toward output, locating intermittents in a minute or two. Bad components quickly located without unsoldering. Field strength feature of Audolyzer accurately checks antenna efficiency. Check high impedance pickups without other apparatus. Check receiver's speaker against Audolyzer's speaker for output quality. Factory circular on this sensational instrument available on request. Regular price \$149.50 SPECIAL \$98.00



## WIRE STRIPPER

- No Tool Box Complete Without It
  - A Big Time and Labor Saver
  - Sturdy Construction Hardened Steel
  - Precision Willed Cutter Easily Replaced
  - Black Finish for Rust Protection
  - Automatic Grip Release After Stripping
  - Automatic
- SIMPLE DURABLE INEXPENSIVE**
- 4-Hole Blade, Takes Wires Up To 1/4" O.D. Gauges No. 14 and Smaller. Sold on a money-back guarantee. **NOW \$2.95**



## 1 FREE RADIO TUBE (OUR CHOICE) SHIPPED WITH EACH PARTS ORDER OVER \$5.00

### Super Midget Mike Xfmr.

Occupies less than 1/2 cu. in. of space. This is the tiny, high quality transformer that is used inside bullet dynamic or velocity mikes to match the input of an amplifier tube. Makes a terrific intercom set input xfmr to couple from the voice coil of a speaker to the amplifier input. Better quality and marked reduction in hum compared to other transformers. A beautiful unit xfmr for a transmitter because of high quality & light weight. Special \$1.60 "postpaid."



**Home Workshop at Bargain Price**  
Accurate and precise 2 speed guaranteed hobby lathe, the essential machine for the home workshop. Sturdy enough for light production work or factory standby service. Supplied with 50° of holding for connecting to any available electric motor or power take-off. Also included in this unbelievable offer are such accessories as a 1/2" drill chuck with specially hardened tool steel jaws, a 1" electric furnace high speed grinding wheel, a cotton buffing wheel and a large supply of buffing compound, and a 3" steel wire scratch brush. Your cost \$6.00. Sole export agent. Distributor inquiries invited.

### SENSATIONAL, FASCINATING, MYSTERIOUS SELBY'S Band new Selbys made by G.E. Company. Two or more connected together work perfectly on 110 V. AC. Any rotation of the shaft of one Selby and all others connected to it will rotate exactly as many degrees in the same direction, following unerringly as if the units were connected together by shafting instead of wire. This is true whether you twist the shaft of the master unit a fraction of a revolution or many revolutions. Useful for indicating direction of weather vanes, rotating directional antennas, or controlling innumerable operations from a distance. Complete with diagrams and instructions. Per Matched pair \$4.95.



## SIGNAL CORPS INTERCONNECTOR RELAY BOX 730A

This valuable unit, made by Bell, and more familiarly known by the U. S. Army designation BC716, is encased in a highly polished aluminum case 6 1/2 x 5 1/2 x 2 1/2", and contains 150 mfd. of condenser capacity, sensitive relays, resistors, and terminal strips. Order several at the giveaway price of only..... \$1.95

# STOP IT'S MOBILE RADIO TIME AT BUFRAD 6 Volt Dynamotor

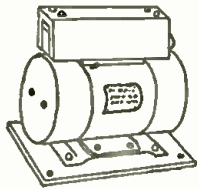

Made for use with G.E. Equipment. Worth over \$250.00. So husky we can give a standard R.M.A. Guarantee on this item. Satisfaction guaranteed or money refunded if returned prepaid within 5 days.

## 1000 V. OUTPUT AT 350 MA.

- By running with end bells removed will supply 500 MA. safely
- Constant output voltage under varying load because of compound winding
- Low input current (18 to 100 amps. depending on transmitter drain)
- Regular car battery will supply enough power for push-to-talk operation
- Starting solenoid for remote operation from mike switch
- Both sides of output voltage insulated from ground
- Brand new in original factory boxes
- Both input and output fused
- Built in interference filter

# Special... \$39.95

## CRYSTAL DIODE

No adjustment required, used in field strength meter, noise limiters, signal tracer probes, wavemeters, or as 1st or 2nd detector. The world's finest detector for crystal sets. Higher efficiency and much greater volume. \$1.75 or 3 for \$1.95.

## 25 or 60 cycle Filament Transformers

- 115V to 12V, 3A..... \$1.35
- 115V to 12V, 2.5 A & 6.3V, 3A..... \$2.00
- 250V to 25V, 1.5A..... \$1.35

Phono motor and turntable, and phono pickup with G.E. reluctance pickup cartridge. Total price..... \$7.95

## Storage Batteries

Large Navy Type Storage Batteries 6V-250 Ampere hours. Shipped Dry, shpg. wt. 60 lbs. Special..... \$25.00

## SPECIAL ANNOUNCEMENT!! FCC AUTHORIZES RADIO FOR PRIVATE SERVICE!!!!

(The FCC announced that effective June 1, any American over 18 years of age may be eligible for a 5 year station permit. In the "Citizens band, no code test or technical knowledge are necessary for transmission.)

**GENERAL ELECTRIC 15 TUBE TRANSMITTER-RECEIVER SET.** This brand new 15 tube transmitter-receiver was designed for mobile storage battery powered service. Properly modified, it will operate on voice in the Citizens Band. It's a cinch for the experimenter to connect this unit for 110-volt a.c. operation by following the instructions and diagrams supplied, which cover numerous applications, including FM and amateur television transmission and reception. For those intending to use on car or boat, a new dynamotor, exactly as originally supplied, costs only \$15.00. Don't fail to write for FREE descriptive bulletin. Order our AT-1248 for only \$29.95, or two for \$53.90.

**Type "A"**—Each unit contains two 4 Mfd. oil filled condensers and a 1 inch inductance 50 Amp. choke in fully shielded case. Suitable heavy current connectors are provided to attach to the input and output connectors at each end of the filter from your input and output wires. A filter with innumerable uses on oil burners, refrigerators, bells, automobiles and wherever noise is to be suppressed or interference abolished. A \$17.00 value for \$2.98.

Admiral Record Changers in metal cabinet. Play 12-10" or 10-12" records. Latest high output featherweight Slime Crystal cartridge. Free removable permanent needle. Original factory cart. Worth double our price of \$18.00 complete.

## SCR 274N Command Set (Made by Western Electric) THE GREATEST RADIO EQUIPMENT VALUE IN HISTORY

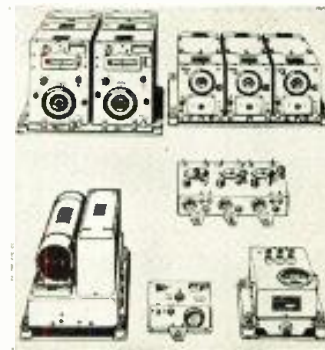

A mountain of valuable equipment that includes 3 separate Communications Receivers, covering up to 9.1 MC. 2 separate 40 watt Transmitters including crystals. 4—28v Dynamotors (easily converted to 110v AC operation). Pre-Amplifier and Modulator, 2 Tuning Control Boxes, and 1 Antenna Coupling Box complete with R.F. Ammeter. 29 tubes supplied in all. Receivers and Transmitters instantly detached from mounting racks for use in separate locations. Removed from unused aircraft and in guaranteed electrical condition. A super value at \$59.95 complete.

## LINE FILTERS

**TYPE "B"**—Heavy duty line filter consisting of 2 condensers and R. F. choke in plated steel case. Conservatively rated at 4 amps and 600 volts. Perfect for refrigerators, oil burners, power supply input of signal generators or to block out almost any interference you can think of. Super special \$1.75 each or \$5.00 10 for.....

Highest quality telescoping folded dipole rooftop type antenna. Tunes to all channels. With all the features usually expected in such an antenna, including use as dipole and reflector, and in addition a mounting bracket provided so that the antenna can be installed in any window in two minutes or less. Any slight loss in gain because of the reduction from rooftop height is more than compensated by the ability to orient the antenna instantly by opening the window and adjust for maximum signal strength. Mounting bar can be installed horizontally or vertically in window frame or even between attic rafters, whichever is most convenient. Your cost \$8.65. With high frequency attachment for channels 7 to 13 \$11.00. Either type 10% in dozen lots.



## BUFRAD CAR RADIO ANTENNAS

All of our car radio antennas are made of triple plated aluminum alloy Brass Tubing. Complete with low loss shielded leads and lots of 12 high quality fittings. **S I D E B A N D** 3 sections extend to 60". Your price—single units—\$2.25, in lots of 12 or more—\$2.00 ea. **SHYSCREW**—BR-2 has heavy duty sections that extend 98". This super-aerial must be seen to be fully appreciated. Your price—single units—\$3.00; in lots of 12—\$2.50 ea. **TILT ANGLE**—BR-3, may be adjusted to all body contours, 3 sections extend to 60". Single unit price—\$2.00; 12 lot price—\$1.75 ea. **VERSATILE**—BR-4, single hole fender or top cowl mounting may be adjusted to conform with all body contours, 4 sections extend to 50". Single unit price—\$3.50; 12 lot price—\$3.00 ea. **THE MONARCH**—BR-5, single hole, top mounting, 3 sections extend to 60". Single unit price—\$2.50; 12 lot price—\$2.00 ea.

## COMPRESSED AIR INSTANTLY ANYWHERE

Portable Air Compressor and storage tank. Ruggedly built. Best Materials. Lifetime lubricated ball-bearing on connecting rod and oil-impregnated main bearing on shaft. Unusual design forever eliminates valve trouble, the most common fault in air compressors. **PATENTED** unique air intake system increases efficiency tremendously so that air output is much greater than that from larger compressors powered by heavier motors. Delivers approximately 3500 cu. inches of air per minute at maintained pressure of 30 lbs., or will inflate a 90 lb. truck tire in less than one minute. Complete with 100 lb. gauge. Finger-tip adjustment allows setting of output pressure at any value, which will automatically be maintained. Works from any 1/4 H.P. motor. Useful for spraying paint, lacquer, disinfectant, insecticide, annealing or brazing with natural gas, inflating tires, etc. Price \$14.50 postage prepaid anywhere in the U. S. Efficient, completely adjustable sphyon type spray gun complete with 12 ft. of 100 lb. tested hose, only \$7.75 with pint container, also prepaid.



## PORTABLE ELECTRIC DRILL TERRIFIC VALUE

Equipped with 1/2" Jacobs geared Chuck **\$19.95** (Sold at less than established factory price so we can mention brand name) Not an intermittent duty drill, but a full size rugged tool. Most convenient type switch. Natural grip handle. Balance like a six shooter. Precision cut gears. Turbine type cooling blower. Extra long brushes. No stalling under heaviest pressure because of powerful 110 Volt AC or DC motor and multiple ball thrust bearings. Other bearings self-aligning lifetime-lubricated Oilite type. Made for toughest year-in and year-out service in plant or on construction jobs. Amazing perpetual factory guarantee assures you of a lifetime of trouble-free use. Satisfaction guaranteed or money refunded if returned prepaid within 5 days.



BUFFALO RADIO SUPPLY, 219-221 Genesee St., Dept. RN-5 BUFFALO 3 N.Y.

# FREE TO TV SERVICEMEN

THE LAST WORD IN TV TENNA INSTALLATIONS



**BRAND NEW AUTHORITY INFORMATIVE**  
Simplifies

## TV-ANTENNA INSTALLATIONS

A fact-filled, pocket size reference manual edited by outstanding authorities. Packed with vital information on all types of antennas, Helpful Hints, Do's and Don'ts, Dimension Guide, Channel Frequencies, Proper Feed Methods and many other subjects.

**LIMITED QUANTITY**  
PUBLICATION PRICE 50c. AVAILABLE WITHOUT OBLIGATION IF YOU WRITE IMMEDIATELY. **FREE!**

MAIL THIS COUPON TODAY

**SNYDER MFG. CO., Dept. K**  
22nd & Ontario Sts., Phila. 40, Pa.

Please send free copy of TV TENNA TIPS

Name.....  
Address.....  
City..... Zone..... State.....

ing there, and has been for four years; has programs three times a day in Spanish, Portuguese, and English; I hope to have further information on this one soon.

*Guatemala*—At the time this was compiled, a note had just been received from Leslie Garrison of TGNA, Guatemala City, stating that delay in getting the 11.850 outlet on the air was because of vacuum condensers; those  
(Continued on page 153)

### Recording Adapter

(Continued from page 65)

enough range for ordinary purposes. When recording, the tone control should be set for maximum high frequency response, and when playing back a recording, the operator should adjust the tone control for maximum bass boost. If the tape-pulling mechanism should be of the type which pulls the tape at 15 inches-per-second, practically no frequency compensation will be needed except some bass boost on playback.

Correct operation of the unit is achieved as follows: One output tube is removed from the amplifier and the plug-socket connector is inserted in its place. The tube is then inserted in the socket of this connector. The erase section of the head is connected to  $J_2$  and the record-playback section is connected to  $J_1$ . A microphone is connected to the input plug of the amplifier and the switches should be turned to "Record" position. The plug  $P_1$  is not inserted, but is left disconnected. A trial recording is then made so that the proper recording level can be determined. A few trials will show that the tape can be overloaded easily, and that good recordings can be made with a relatively low setting of the volume control. If the amplifier is equipped with a tone control it should be set to the "Treble" position.

After the tape has been rewound, the switches are turned to the "Play" position and the plug  $P_1$  is inserted into the "Microphone" input of the amplifier in place of the microphone. The tone control is set for maximum bass boost. Although the high frequency bias voltage delivered by this oscillator is not critical, the operator should know that a signal which is deficient in high frequencies may have been recorded with too high a bias voltage. Conversely, a signal with high distortion and high background noise usually indicates insufficient bias voltage. The bias voltage can be adjusted by increasing or decreasing  $R_1$ , as before indicated.

Although the use of this adapter with an ordinary amplifier is not expected to achieve the results of a high quality amplifier made especially for magnetic recording, its use with a good amplifier will give results which may exceed those obtained with many of the lower priced magnetic recorders which are on the market at the present time.

# VARIETY

COVERS THE WORLD IN TELEVISION · RADIO · INDUSTRIAL · TEST EQUIPMENT & SUPPLIES

- Super Powered
- Greater Sensitivity
- Longer Range
- Superior Definition
- RMA Guarantee



### The famous VIDEO PRODUCTS #630 TV CHASSIS

Licensed by Radio Corporation of America

#### ★ THE HIGHEST STANDARDS OF TELEVISION EXCELLENCE ★

- 30-tube high quality television chassis, (incl. 3 rectifiers)
- Keyed AGC—Complete noise immunity
- Superior interlace and horizontal and vertical linearity
- Full four megacycle overall picture band-width
- Greater dynamic Video range for superior definition and better picture tone contrast
- Automatic Brightness Control
- Syncroloc—Stabilized horizontal and vertical hold
- Unequaled performance in difficult reception areas
- Available with Standard Coil lang-range tuner
- Phono connection for record player
- Limiter Discriminator FM sound system for noise-free and high quality sound reception
- High Efficiency, high voltage circuit; 14 KV under load
- Full width and focus for all Cathode Ray tube sizes and types

New low price **\$159.50** tax incl., plus transportation less CR tube

20% Deposit with Order Required, Balance C.O.D.

Amazing values on

#### KINETRON PICTURE TUBES

From a Famous Manufacturer • Fully Guaranteed

Available in the following sizes:

10" tube.....	\$14.95	16" tube.....	\$24.80
12" tube.....	20.95	17" tube.....	24.80
14" tube.....	22.50	19" tube.....	43.95
20" tube.....	\$44.95		

To Be Sure, Call On Variety First for Everything You Need

**VARIETY ELECTRIC CO. INC.**  
468-470 BROAD STREET  
NEWARK 2, NEW JERSEY

### BRAND NEW TUBES

1B22	\$ 2.95	354	\$ 0.98	7078	\$14.95
1B27	17.95	4C35	29.95	717A	1.45
1C3K	29.95	4J31	89.50	723A B	14.95
2C40	4.49	6AB7	1852	7348	2.75
2C44	1.44	6AN5	4.95	75A	6.95
2C51	4.95	6BB	1.39	76C	49.50
2D21	1.59	6SH7GT	3.94	812	5.95
2J21A	14.95	12A6	.98	812A	0.95
2J22	22.95	12H6	.89	817	1.95
2J32	34.50	32L7GT	7.94	812A	1.95
2J34	37.50	250R	9.95	884	1.75
2J34	37.50	304TL	22.95	1036	1.38
2J34	37.50	446A	1.19	1019	2.29
2J82	41.50	446B	1.88	1025	.48
3E24	3.50	700A B D	16.95	1020	1.98
3E29	19.95	706CY	39.50	1028	4.95
3Q4	.98	706CY	49.50	1003	1.78
9001	1.75	9002	1.50	1005	1.78

Send us your inquiries! We carry a complete stock of Radio and TV Receiving Tubes. We also buy surplus stocks in tubes!

**J. S. H. SALES CO.**  
Dept. R, 7552 Melrose Ave., Los Angeles 46, Calif.

## Defense Transceiver

(Continued from page 43)

with the r.f. chokes must be handmade. If the dimensions are followed closely the receiver and transmitter should be within the 220-225 mc. band. The author has a heterodyne frequency meter with which to spot the band. However you may use Lecher wires or if you have a television set with the standard 21 mc. i.f. then if you tune to Channel 11 the TV oscillator will radiate a weak carrier at 225 mc. If your receiver is too low in frequency and TV Channel 13 is used in your area, you should hear the sound from this station which is on 216 mc.

The antenna used with this receiver consists of a 25" length of 3/8" copper tubing the center of which is fastened to one end of a 1 1/4" square length of pole. This solid dipole is delta fed with a short length of 300 ohm TV line. The 300 ohm line is split back for 7 inches. One end of the wire is soldered 3 inches out from the center of the dipole while the other wire is soldered the same distance out on the other side of the dipole, thus forming a triangle. The 300 ohm line should be tied back tight along the wooden antenna support so that the delta match does not sway in the wind. If you expect to use a feed line longer than 25 feet do not use 300 ohm TV line as the losses will run too high. For long runs use two #18 wires spaced 1". Use lucite spreaders 1/4" x 1/4" x 1 1/2" spaced every 12" along the line or purchase a similar low loss line manufactured by *Gonset Company*, Burbank, California. A 100 foot length of either of these feed lines causes only .5 db. loss at 200 mc. Vertical polarization is used on this band in the East.

The power supply is not described here but it should furnish 6.3 volts at 1.5 amperes for filaments and a maximum of 300 volts at 70 milliamperes d.c. for "B" supply. With the antenna and power supply connected, advance the regeneration control until the 955 detector goes into the usual hiss associated with superregeneration. If the antenna coil is too tightly coupled the detector will not operate smoothly. The regeneration control usually need not be advanced more than to feed 20 volts to the 955. Due to the split stator condenser the maximum dial spread can only be 90 degrees. The gain control not only adjusts the audio volume on the receiver but also the modulation level during transmission. Should the receiver not exactly cover the band the tank coil may have to be spread very slightly to go higher in frequency or compressed very slightly to go lower in frequency. At these frequencies it is essential to keep all your leads as short as possible.

After the receiver is functioning properly turn the switch from "Receive" to "Send." Next to the transmitter coil insert a two-turn coil wired to a brown bead 6-8 volt pilot lamp.

## Real values on hard-to-obtain items

### "S" METER . . . An outstanding buy!



Here is a beautiful instrument exactly suited for use as an "S" meter. Illuminated face, (supplied with miniature lamp) with a full-scale reading of 5 ma, a standard value for most "S" meter circuits. Diameter across face is 2 3/8", black bakelite case, reverse-set pointer. New, surplus . . . limited quantity. Only . . . \$1.95 ea.

836 hi-vacuum rectifiers. 2 for . . . \$1.50

### TRANSFORMERS-CHOKES:

2.5V, 10A, 10KV insulation. Suitable for 866, 836, etc. Reduced to \$3.39 ea.  
10H, 200 ma choke. Hermetically-sealed steel case. Also has hum-bucking tap. A beautiful item only \$1.98.

10H, 50 ma choke. Strap mounting. Handy for dozens of applications. Reg. 98c, reduced to 65c. Charger or fil. trans. Pri. 110V, 60 cycle. Secondary, 9-10-11-12-13 volts @ 1.2 A. Fully cased. A buy at \$1.49.

Vibrator transformer. 6V inp. Secondary 345-0-345 @ 150 ma. Also has bias winding. Fully cased. Bargain at \$1.49 ea.

Power transformer. 780V, CT @ 200 ma. 2.5V at Sa. 5V at SA. 6.3V at 6A. Pri. 115V, 60cy. AC. Has electrostatic shield. Upright mount. Shipping weight 11 lbs. Only \$5.95.

Power Transf. 350-0-350 @ 70 ma. 5V @ 3A. 6.3 @ 3A. Pri. 110V, 60 cy. AC. Upright mtg. . . . \$3.25 ea.

Power transf. Pri. 115V, AC, 60 cy. Sec. 520-0-520 @ 200 ma. . . . \$5.25 ea.  
Power transf. Pri. 115V, 60 cy. AC. Sec. 310-0-310 at 50 ma. Cased, upright mount. . . . only \$1.95 ea.

Output transf. 50L6 to voice coil. . . . 79c ea.  
Choke, 6 henry, 200 ma. Strap mtg. . . . only \$1.95 ea.

HS-16 phones. Used, with headband and 6' cord. A hot buy at . . . \$98c

RCA Hand Mike. Hi-grade, single button. Bronze colored w/cord and plug. NEW. Were \$1.98, now reduced to 98c ea.

### TELEPHONE EQUIPMENT:

EE89 Repeaters (see previous ads). Only a few left. NEW! Regularly \$9.95 ea. . . . now \$6.95 ea.  
TS-10 Sound powered handsets. A limited quantity only. BRAND NEW! . . . \$25.95 pair  
Handset hanger. Beautiful cast aluminum shell finished in black wrinkle. Takes all makes and models. An extremely useful, well-made item only \$1.95 ea.

### 274N/ARC-5 ACCESSORIES

Mounting rack, holds three receivers. Easily modified for single receiver. NEW. . . . only \$1.95 ea.  
274N ARC-5 Spline tuning knobs. . . . \$9 ea.  
Same as above except with deluxe tuning crank . . . \$9 ea.  
Tuning crank. Fits RU 16-17, BC 433 etc. for manual tuning . . . \$9 ea.

### HV VACUUM CAPACITORS

VC-50 — 50 MMF . . . \$ 3.95 ea.  
VC-150—150 MMF . . . 10.95 ea.  
VC-150—200 MMF . . . 13.95 ea.  
All Brand New Merchandise—Excellent Values.

### 100 KC CRYSTAL

Model VC5-KS Precision 100 KC crystal in holder. (Similar to Biley AR21-W.) Ideal for Crystal Calibrators and Frequency Standards. A Buy At . . . \$3.95 ea.

### ALUMINUM CHASSIS

Drawn, Bright Dipped. 5 1/4" long, 3 3/8" wide, 1 7/8" deep.  
Bargain At . . . \$49c ea.

### CONDENSER TESTER

• One of our best sellers! Useful, versatile laboratory item, in kit form. Simple, and easy to build in less than an hour. Checks condenser leakage and continuity up to 8 megs. Will test any paper, electrolytic, mica or oil capacitor from 50 mmf. to 50 mfd. Self-contained power supply and neon bulb indicator with socket and bezel. Drilled metal cabinet. Complete instructions and diagrams included with each kit. Only \$5.00.



### THE WELL-KNOWN "Q5'er"!

Special purchase on this outstanding unit. Frequency range 190 to 550 kc. 85 kc I.F. Complete with full tube complement.  
Used, good condition. . . . only \$10.95 ea.  
R-23-ARC/5. Identical receiver to above except has switch to change from antenna to direction finding loop. Makes a wonderful L.F. direction finder. With tubes.  
Used, good condition. . . . only \$10.95 ea.

SCR-522 Receiver. Used, good condition. Less tubes \$14.85 ea.

0-1000 DC MILLIAMMETER.  
Beautiful, full vision 3" round case made by De Jur. Brand new . . . only \$2.95 ea.

### ALUMINUM CHASSIS

Sturdy, drawn aluminum chassis. Black wrinkle finish, surplus. 11 1/8" long, 2 3/8" wide, 2 1/8" high . . . Only 95c ea.

### 15 OHM RHEOSTATS

Rated at 25 watts. Ohmite Type "H." . . . Only \$.50 ea.

### SCOPE COMBO OFFER

The makings for an excellent scope. Includes: 1-5N1 C-R tube, transformer for hi-voltage and fil. for 2X2 rectifier, circuit diagram. only \$7.95

FL-8 Filters. New. . . . only 98c ea.

### ULTRA-VIOLET LIGHT SOURCE FOR TELEVISION AND C/R TUBE EXAMINATION

O-R now presents . . . new . . . an 8-watt, ultra-violet, "black-light" source! Here is a highly effective and time saving device for checking burn spots and other defects in phosphors of C/R tubes. C/R tube face fluoresces when exposed to this special black-light to give visual indication of condition of phosphor. Reflected light from C/R tube face is negligible and tube does not have to be in operation. An invaluable device for TV service shops, schools, laboratories. Also used in medical, chemical, foods, stamps, criminology . . . a thousand uses.

In kit form including Sylvania 8 watt, black-light tube, ballast, starter, mounting panel, tube clips, reflector, line cord/plug, hardware, instructions. Simple shadow box for outer housing is easily made.

Complete kit (less outer housing) . . . only \$4.95



### NEW! PORTABLE GEIGER COUNTER

A small light-weight unit (2 pounds), with a sensitivity that compares favorably with instruments many times its purchase price. Rugged and dependable and intended for professional use. Batteries used provide long life and low replacement cost. Each Geiger counter comes complete ready for use with instructions and radio-active ore sample for comparison tests. . . . \$35.00

### TU-10 B TUNING UNITS

The best of the BC-375 tuning units. Has three, transmitting type variables, H.V. micas, RF chokes, Velvet Vernier tuning dials, worm-gear reduction. Really a wonderful source of excellent components . . . only \$1.75 ea.

### VACUUM TUBE SPECIALS

8012 . . . UHF triode . . . \$1.50 ea.  
WE-717A . . . . . 1.00 ea.  
WE-316A . . . Trans. doorknob . . . . . 75c ea.  
WE-388A . . . Large doorknob . . . . . 1.00 ea.  
815 . . . twin-beam tet. . . . . 2.50 ea.  
6L6 . . . metal . . . . . 2.25 ea.  
6L6G . . . . . 1.95 ea.  
6L6GA . . . . . 1.95 ea.  
1636 . . . VHF converter . . . . . 1.00 ea.

### LOOK! NO HANDS!



This mike leaves both hands free for mobile QSO's. Fastens to operator by simple snap strap. Adjustable. Double action sw. operates push-to-talk or holds on. BRAND NEW only \$2.00 ea. POSTPAID in U.S.A. and CANADA.

MINIMUM ORDER \$2.00. ALL ITEMS SUBJECT TO PRIOR SALE.

ALL PRICES SUBJECT TO CHANGE WITHOUT NOTICE.

20% DEPOSIT MUST ACCOMPANY ALL ORDERS, BALANCE C.O.D.

## OFFENBACH & REIMUS CO.

372 ELLIS ST.

SAN FRANCISCO, CALIF.

PHONE ORday 3-8551

# BUILD 15 RADIOS At Home

WITH THE NEW IMPROVED 1951  
PROGRESSIVE RADIO "EDU-KIT"

ONLY ... \$19.95

FREE TOOLS  
WITH KIT

ABSOLUTELY NO  
KNOWLEDGE OF  
RADIO  
NECESSARY

NO  
ADDITIONAL  
PARTS  
NEEDED

EXCELLENT  
BACKGROUND  
FOR TELEVISION



10-DAY MONEY-BACK GUARANTEE

WHAT THE PROGRESSIVE  
RADIO "EDU-KIT" OFFERS YOU

The Progressive Radio "Edu-Kit" offers you a home study course at a rock bottom price. Our Kit is designed to train Radio Technicians. With the basic facts of Radio Theory and Construction Practice expressed simply and clearly, you will gain a knowledge of basic Radio Principles involved in Radio Reception, Radio Transmission and Audio Amplification.

You will learn how to identify Radio Symbols and Diagrams; how to build radios, using regular radio circuit schematics; how to mount various radio parts; how to wire and solder in a professional manner. You will learn how to operate Receivers, Transmitters, and Audio Amplifiers. You will learn how to service and trouble-shoot radios. In brief, you will receive a basic education in Radio exactly like the kind you would expect to receive in a Radio Course costing several hundreds of dollars.

#### THE KIT FOR EVERYONE

The Progressive Radio "Edu-Kit" was specifically prepared for any person who has the desire to learn Radio. The Kit has been used successfully by young and old in all parts of the world. It is not necessary that you have even the slightest background in science or radio.

The Progressive Radio "Edu-Kit" is used by many Radio Schools and Clubs in this country and abroad. It is used by the Veterans Administration for Vocational Guidance and Training.

The Progressive Radio "Edu-Kit" requires no instructor. All instructions are included. All parts are individually packaged, and identified by name, photograph and diagram. Every step involved in building these sets is carefully explained. You cannot make a mistake.

#### PROGRESSIVE TEACHING METHOD

The Progressive Radio "Edu-Kit" comes complete with instructions. These instructions are arranged in a clear, simple and progressive manner. The theory of Radio, Transmission, Radio Reception and Audio Amplification is clearly explained. Every part is identified by photograph and diagram; you will learn the function and theory of every part used.

The Progressive Radio "Edu-Kit" uses the principle of "Learn By Doing." Therefore you will build radios to illustrate the principles which you learn. These radios are designed in a modern manner, according to the best principles of present-day educational practice. You begin building a simple radio. The next set that you build is slightly more advanced. Gradually, in a progressive manner, you will find yourself constructing still more advanced radio sets, and doing work like a professional Radio Technician. Altogether you will build fifteen radios, including Receivers, Amplifiers and Transmitters.

#### THE PROGRESSIVE RADIO

##### "EDU-KIT" IS COMPLETE

You will receive every part necessary to build 15 different radio sets. This includes tubes, tube sockets, variable condensers, electrolytic condensers, mica condensers, paper condensers, resistors, file strips, coils, tubing, hardware, etc. Every part that you need is included. In addition, these parts are individually boxed, so that you can easily identify every item.

#### TROUBLE-SHOOTING LESSONS

Trouble-shooting and servicing lessons are included. You will be taught to recognize and repair troubles. While you are learning in this practical way, you will be able to do many a repair job for your neighbors and friends, and charge fees which will far exceed the cost of the Kit. Here is an opportunity for you to learn radio and have others say for it.

#### FREE EXTRAS IN 1951

- ELECTRICAL AND RADIO TESTER
- ELECTRIC SOLDERING IRON
- BOOK ON TELEVISION
- RADIO TROUBLE-SHOOTING GUIDE
- MEMBERSHIP IN RADIO-TELEVISION CLUB
- CONSULTATION SERVICE
- QUIZZES

The Progressive Radio "Edu-Kit" is sold with a 10-day money-back guarantee. Order your Progressive Radio "EDU-KIT" Today, or send for further information.

**PROGRESSIVE  
ELECTRONICS CO.**

497 UNION AVE.  
DEPT. RN-5 BROOKLYN 11, N. Y.

This lamp will burn bright if the 6J6 is oscillating. Now whistle into the microphone. If the light fluctuates with modulation undoubtedly the modulator is functioning properly. By using Lecher wires with the pilot lamp very loosely coupled you can determine the frequency. The other methods mentioned can also be used to put the transmitter on frequency. If the rotor plates of the butterfly condenser are about 1/2 meshed with the stators you will be fairly close to the center of the band.

A number of two-way tests have been made over a 17 mile path from home QTH's with this station and the signals were about R3, S3. While this type of communication is not within the design requirements of this station it is mentioned only to put at ease those doubting souls who can't believe 2 watts of carrier is sufficient for consistent 5 mile communications.

-30-

## NEW CERAMIC TUBE

THE first commercial ceramic tube ever made, capable of operating up to 900 mc. at 1 kw. output, was recently introduced by General Electric Company's Tube Divisions at the IRE Convention in New York.

The new tube, the Type GL-6019, was designed primarily for u.h.f. television transmitter service.

The all-ceramic and metal power tube is capable of operating up to and beyond the top frequency (890 mc.) of the proposed u.h.f. television channels. The use of ceramic in the new tube minimizes the problem of high frequency losses and makes envelope cooling problems less difficult than with glass tubes.

The new tube has several other features. A gold-over-silver plating on all external metal parts provides low-loss electrical contacts. The concentric ring-seal construction enables the tube to be easily inserted or removed from its cavity. Water pipes are so arranged that connections can be made outside the r.f. cavity.

Maximum ratings of the GL-6019 at synchronizing level for class B television service include: d.c. plate voltage, 4000 volts; d.c. screen voltage, 600 volts; d.c. plate current, 700 ma.; plate input, 2.5 kw.; and plate dissipation, 2 kw. -30-

General Electric's new ceramic tube which is designed to operate up to 900 mc. at 1 kw. output. The Type GL-6019 was designed for u.h.f. television transmitter use.



Easy, fast  
way to cut  
"Key" and "D"  
openings  
in chassis

...with new GREENLEE  
Radio Chassis Punches



No. 732 "Key" Punch



No. 733 "D" Punch

Now, in 1 1/2 minutes or less make perfect "Key" or "D" holes for sockets and other equipment. Simply insert GREENLEE Punch and turn with an ordinary wrench... get a "clean" opening in a hurry! Write today for details on these as well as GREENLEE Radio Chassis Punches for round and square openings. Greenlee Tool Co., 1885 Columbia Ave., Rockford, Illinois



a  
message  
to  
music  
lovers  
and

record playing enthusiasts!

Your records, (LP's or Standard) need not produce fuzzy, noisy, distorted music. Inherent in their sound grooves is fine musical realism of concert hall quality that can be recreated by record players equipped with fine audio components: pickup, arm, compensator, preamplifier, etc. Such components by Pickering are the finest available: the choice of engineers, leading record critics, music lovers and specialists in the production of custom record playing systems.

Pickering High Fidelity Components are available through leading jobbers and distributors everywhere; detailed literature will be sent upon request.

**Pickering & Co., Inc.**  
Oceanside, N. Y.

Address  
Department C

For the utmost in quality  
specify Pickering Audio  
Components!



**Spot Radio News**

(Continued from page 16)

the Commission reported that in all communities having three or more assignments (very-high or ultra-high), one channel for educational work had been reserved. In those communities with fewer than three assignments, no reservation had been made, except in places which are primarily educational centers, where reservations were spotted even where only one or two channels were assigned.

The educational allotment did not strike Madam Commissioner Frieda Hennock as adequate, and in a lengthy dissent, she said that . . . "failing to give the schools a sufficient share of the remaining television spectrum, will adversely affect the course of education in the United States for generations to come." She felt that the reservation of approximately ten per cent of the total assignments . . . has failed to provide facilities for education in a large number of cities of substantial size. . . . Thus, there is no frequency reserved in more than one-fourth of the one-hundred and sixty-eight standard metropolitan areas. . . . The Commission's proposal for many of our largest cities, such as New York, Los Angeles . . . confines the reservation to the ultra-high band, and makes no provisions for educational broadcasting in the very-high frequency band now in use."

In a caustic commentary on the immediate future of higher-band operation Miss Hennock declared that up to now ultra-high work has been purely experimental and . . . "we have no assurance as to when ultra-high equipment will be available and ultra-high stations in operation." Pointing out that in each of the larger cities, there are at least three or more standard-band stations in operation, and that only through extensive conversions to the millions of sets now in operation will it be possible to receive the new high-band stations, Miss Hennock declared that the audience prospects for the higher bands are quite remote.

"In these circumstances," cites Madam Commissioner, "the Commission quite properly indicates concern that even commercial interests in the ultra-high bands will be required to face substantial economic problems, beyond those ordinarily faced by a very-high operation. . . . How then, can the Commission, consonant with practical realities of the situation, force educators in these localities to carry the additional burden of ultra-high operations, which they are clearly ill-equipped to do?"

A blistering dissent, issued by Commissioner George Sterling, declared in part that . . . "It would seem to me that it is in the public interest to make available the greatest number of very-high channels at the earliest date possible so as to provide increased com-

**NEW for '51**  
**Automatic Radio**  
CUSTOM-BUILT AUTO RADIOS

**RECORD SMASHING VALUES!**

1949 AND 1950 PLYMOUTH-DODGE RADIOS

1949, 1950 and 1951 FORD AUTO RADIOS

1949, 1950 and 1951 CHEVROLET RADIOS

1948-49-50-51 HUDSON  
1951 HENRY J  
1949-50-51 STUDEBAKER

List Price . . . . . \$59.95

ATTRACTIVE DISCOUNTS TO DEALERS

1949, 1950 and 1951 FORD AUTO RADIOS

List Price . . . . . \$59.95

1949 AND 1950 PLYMOUTH-DODGE RADIOS

List Price . . . . . \$59.95

1949, 1950 and 1951 CHEVROLET RADIOS

List Price . . . . . \$59.95

Each auto radio is specifically designed to fit all 1949 and 1950 cars shown above and all incorporate the same outstanding features. . . . Six-tube superheterodyne. Six-volt storage battery operation. Two dual-purpose tubes. Eight-tube performance. Installation in a few minutes. Three-gang tuning condenser and tuned R.F. stage for extreme sensitivity. Permanent magnet dynamic speaker with Powerful Alnico #5 magnet. Low battery drain. Weight 10 lbs.

**SPECIAL**

Navy entering type insulator. Porcelain flanged bowl with brass rod and fittings and aluminum shield. Dimensions: 4 1/2" high, 6.5" O.D. at base. . . . \$3.95  
Spare bowl . . . . . .50

**CAPACITORS**

UPRIGHT MOUNT	EA.	TEN
2X.25 MFD 400 VDC	\$.35	\$.30
1 MFD 400 VDC	.40	.35
2X.05 MFD 600 VDC	.40	.35
2X.1 MFD 600 VDC	.40	.35
1 MFD 800 VDC	.45	.40
1 MFD 600 VDC	.45	.40
1 MFD 800 VDC	.45	.40
1 MFD 600 VDC	.45	.40
40 MFD 25 VDC	\$.45	\$.35
1 MFD 400 VDC	.45	.40
4 MFD 100 VDC	.55	.50
2X.1 MFD 400 VDC	.60	.55
2 MFD 400 VDC	.55	.50
.05 MFD 600 VDC	.35	.30
.25 MFD 600 VDC	.40	.35
1 MFD 800 VDC	.40	.35
1 MFD 600 VDC	.40	.35
1 MFD 800 VDC	.40	.35
1 MFD 600 VDC	.40	.35
2X.1 MFD 1000 VDC	.55	.50
2X.1 MFD 1000 VDC	.65	.60
<b>OIL FILLED</b>		
1 MFD 400 VDC	\$.65	\$.60
1 MFD 500 VDC	.55	.50
1 MFD 500 VDC	.70	.65
1 MFD 600 VDC	.85	.80
4 MFD 600 VDC	1.15	1.10
1 MFD 1000 VDC	1.40	1.35
1 MFD 600 VDC	1.85	1.80
1 MFD 600 VDC	2.75	2.65
5 MFD 1000 VDC	.95	.90
2 MFD 1000 VDC	1.85	1.80
5 MFD 2000 VDC	2.00	1.90
.25 MFD 3000 VDC	2.85	2.80
.5 MFD 3000 VDC	2.95	2.90
1 MFD 7500 VDC	7.50	7.00
1 MFD 7500 VDC	12.50	12.00
1 MFD 12000 VDC	14.95	14.90
.004 MFD 15000 VDC	12.95	12.75
.045 MFD 16000 VDC	12.95	12.50
<b>PAPER</b>		
8-8 MFD 600 VDC	\$2.25	\$2.15
3X8 MFD 600 VDC	\$2.55	\$2.40
8-8 MFD 650 VDC	2.45	2.25
160-160 MFD 150 VDC	1.25	1.15
<b>ELECTROLYTICS</b>		
2500 MFD 3 VDC	\$.40	\$.35
500 MFD 12 VDC	.90	.85
25 MFD 25 VDC	.40	.35
50 MFD 25 VDC	.60	.55
1000 MFD 25 VDC	1.25	1.15
150 MFD 50 VDC	.50	.45
<b>TRANSFORMERS</b>		
<b>PRIMARYS 115V 60CY</b>		
9V @ 750 MA. 6.3V @ 3.0A.		
5V @ 6A. 2400 Test.	\$.32	\$.25
6.6V @ 0.6A. 2000V Ins. 2.60V @ 1.75A. 2700V Ins.	2.75	
6.4V @ 10A. 6.3 @ 0.8A	3.45	
660/330V @ .08A CT 5.0/2.5	3.25	
350-0-350 @ 120 MA. 5V @ 3A.		
6.3V 4A CT 6.3V	4.25	
<b>SPECIALS</b>		
80.86 KC Crystal with Holder.	\$2.50	
CD.501A Cord Connects BC-654		
Transceiver to GN-45 Gen.	1.95	
Balloon with Hydrogen Gen.	2.50	
Gibson Girl Box Kite		
17"x17"x36"	2.25	
33-440 Mmf Variable Condenser	1.10	
7-100 Mmf Variable Condenser	.95	
24-750 Mmf Tapered Rod		
Plates	1.25	
American Blower and Motor—G.E. 1/4 HP 115V 1 Phase 60 Cy 1725 RPM.		
Brand New	24.95	

**CHECK THESE VALUES**

1C-700 Interphone Amplifier. Ideal for aircraft-booster telephone. New. . . . \$ 4.00

MN-26Y Radio Compass Receiver. 325 + 6D5KC. 3.4 - 7.0 MCS. 2K volt Bendix. Brand new. . . . 44.50

RA-10DB Receiver. Bendix. New. . . . 39.95

BC-733D Receiver. new. less dynamotor. . . . 19.95

BC-224 Receiver. new. less mfg. . . . 11.95

BC-412 5" Radar Oscilloscope. . . . 100.00

RS/ARN-7 Radio Compass Receiver. w/ L u b o s. used. excel. cond. . . . 39.95

BC-433G Radio Compass Receiver. used. excel. cond. w/tubes. . . . 39.95

**TUBES**

2C34	\$.05	1G26	\$.05
2X2/870	.90	1929	.40
2C24	2.20	2051	.95
7C4/1203A	.85	7193	.50
10Y	.45	801	2.40
3B7-1291	.65	608	9.75
6X4	.55	CEQ72	1.40
30 Spec.	.65	CK-70	4.25
39/44	.65	CRP-72	1.40
45 Spec.	.80	E1148	.30
600	.35	UT-98	21.00
316A	.75	RKR-12	.90
W1-531	4.95	RK-73	.75
202A	.50	HT-61	.40
713A	1.45	VT-127A	3.75
801A	.55	3BP1	3.45
803	4.45	3BP4	5.95
826	.95	5P7	1.95
931A	5.50	1J6G	.95
864	.45	3A4	.60
800B	29.95	6SG7	1.95
41003	.85	6X4	1.45
CK1007	1.20	33	.65

**RELAYS**

6 VDC DPST Contacts 6A Coil 31 Ohms . . . . . \$0.65

12 VDC DPST Allied Control Box #302 . . . . . 1.25

24 VDC 3 PDT 8 Amp. . . . . .95

24 VDC Solenoid. Operates 2 Switches. . . . . 1.75

40 VDC DPST-SPDT 1000 Ohm . . . . . 1.80

110 VAC DPST 1 Amp Contacts Str'th's Dunn CNA . . . . . 3.65

110 VAC DPST 25 Amp Contacts Ward Leonard. . . . . 3.95

115 VAC DPST Str'th's Dunn CNA-2907 . . . . . 3.65

220 VDC DPST Str'th's Dunn CX2122 . . . . . 4.50

**Ceramic Rotary Switches**

Pole Position	Section	Shaft	Price	
2	3	6	1 1/8"	\$.60
2	4	4	1 1/8"	.55
2	8	2	2 1/8"	.55
4	10	2	3 1/8"	1.60
4	12	2	4"	.75
2	8	2	30A 9KVA Flash Over	2.50
2 Pole 2 Circuit 6 Cont. W/Knob				.40
DPST Toggle Switch 3A 250V				.35

**TRANSMITTING MICA**

.065 MFD 1800 VDC	\$.65
.068 MFD 2000 VDC	.65
.092 MFD 2000 VDC	1.20
.092 MFD 2500 VDC	1.15
.00025 MFD 5000 VDC	2.60
.00075 MFD 5000 VDC	2.75
.002 MFD 5000 VDC	2.95
.001 MFD 6000 VDC	3.50
.0007 MFD 5000 VDC	8.95
.0002 MFD 6000 VDC	9.50
.0012 MFD 20,000 VDC	32.50

**VALUES**

De-Ion Line Starter DPST 115V 60 Cy 15A West. New. \$6.95

Genuine Upright Desk Telephone and Ringing Box. New 4.95

1-100 Second Delay Line 15 KVA 400 Cy 50 Ohm. New 24.95

CR-122 3 Conductor Cable. . . . .

**ROUND PANEL METERS**

0-5 RF Amps—Westing	3 1/2"	\$4.50
0-300 MA DC—Simpson	2 1/4"	3.75
5-0.5 MA DC—Weston with Multiplier	2 1/4"	5.95
50 MA—Shunt	3 1/2"	5.25
0-50 Amps DC—Weston	3 1/2"	5.75
0-100 Amps DC—Hoyt	3"	5.00
0-3 Volts DC—Sun	2 1/2"	3.50
0-15 Volts AC—GE	3 1/2"	4.95
0-2500 Volts DC—Simpson	3 1/2"	5.95
0-5KV DC 0-10 MA DC	3 1/2"	5.50
0-150 Volts DC—Hoyt	3 1/2"	4.50
<b>PORTABLE METERS</b>		
0-10 Amps DC—Weston	489	9.50
0-3-6-30 Volts DC—Weston	280	19.95
0-100 Amp DC—Weston with 100 Amp—Shunt	269	27.95
0-25 Amps AC—Weston	433	37.50
0-1.5-6 Volts AC Output-meter—Weston	571	14.95

**LINEAR POTENTIOMETERS WW**

Ohms	Watts	Mfr's	Ea.	Ten
200	2	Chicago Tel.	\$0.45	\$0.40
1000	2	Trefz	.50	.45
3000	2	Chicago Tel.	.55	.50
10,000	2	Chicago Tel.	.55	.50
5000	3	Trefz	.50	.45
7500 dual	3	Trefz	.85	.80
10,000	3	Trefz	.55	.50
25,000	3	Wirt	.65	.60
50,000	4	Trefz	.90	.85
15	25	Ohmite	.95	.90
25	25	DeJur	.95	.90
50	25	DeJur	.95	.90
100	25	IRC	.95	.90
200	25	DeJur	1.20	1.10
500	25	DeJur	1.20	1.10
1000	25	DeJur	1.30	1.25
3000	25	DeJur	1.40	1.35
15,000	25	DeJur	1.70	1.60
20,000	25	DeJur	2.00	1.95
150/Switch	50	AN 3155-50	2.15	2.00
200/W Switch	50	IRC	2.15	2.00
800	50	Ohmite	2.65	2.50
10,000	50	DeJur	2.95	2.75
15	50	Ohmite	2.95	2.75
75	50	IRC	2.85	2.75
750	150	Ohmite	3.95	3.85
20,000	5	Helipot 0.5%	9.50	—
20,000	5	Muter 5%	433AC	8.50
5000		Gen. Radio #10	1.95	—
6000		Muter 314A	2.25	—

**POWER EQUIPMENT**

Voltage Regulator Raytheon 85/130 V 60 Cy 1.25 Amp Output 115V 60 Watt. New. \$12.50

Generator Voltage Regulator 115V 400 Cy GE GBA-20C. New. . . . . 19.95

Vibrapak VPC 300 12 VDC Output 250V @ 70MA Synchronous Mallory. New. 5.95

ATR Inverter and Regulator 110VDC to 110 VAC 50/60 Cy 150 Watt Model RSB. New. . . . . 24.95

VIBRATOR ATR 2411 24 VDC Output 110V 100W. New. . . . . 2.50

**TIME DELAY SWITCHES**

1 Minute 115 VAC 60 Cy Enc. in Waterproof Metal Case. . . . . \$5.25

3 Micro Switches with Contact at 40-41-42 Sec. Time Delay 110 VAC Motor. New. 4.50

Thermo Switch 50° to 300° F. 115 VAC @ 6A. 230 VAC @ 5A Breaks Contact with Increase of Temperature. New 1.35

30-40 Second Mercury Time Delay Relay 110 VAC ASD-Inke. New. . . . . 7.50

**TERMS:** Minimum order \$5.00—Mail orders promptly filled—All prices F.O.B. Boston, Mass. Send M.O. or check. Shipping charges sent C.O.D. 25% deposit required with all C.O.D. orders.

Prices Subject to Change without Notice  
**SEND FOR OUR CATALOGUE**  
Inquiries from Dealers, Schools and Industrial Firms Invited

**COMET ELECTRONIC SALES CO.**  
22 Washington St. • BEacon 2-7863 • Brighton 35, Mass.



## ENTER RADIO-TV ELECTRONICS *thru this Proven Plan*

As a young man with a career to build, you may *today* be interested primarily in training for Radio — and perhaps for TV. But — *who knows* . . . you may some day have both the desire and opportunity to climb further and become an Electrical Engineer! Here, then, is a world-renowned educational plan that permits you to use your Radio training as a major stepping-stone to an even greater career.

### IN 12 MONTHS BECOME A RADIO TECHNICIAN

Train here for radio shop operator or serviceman, mobile receivers and all types of transmitters, and for supervision of service personnel. You may then advance immediately, or at any future date, into courses described below.

### IN 6 ADDITIONAL MONTHS you become a Radio-Television Technician

An additional 6-months course gives you intensive TV Technician's training — under the *personal guidance* so necessary in this expanding field.

### ALSO...YOUR RADIO COURSE IS FULL CREDIT TOWARD THE B.S. DEGREE IN ELECTRICAL ENGINEERING

The Radio course, while complete in itself, is *one-third* of the college program (major in Electronics). Further — you are guided scientifically toward specialization beyond basic engineering training.



*B.S. Degree in 36 months.  
Military, practical or prior  
academic training evaluated  
for advanced credit.  
Terms open July, October,  
January, April.*

## MILWAUKEE SCHOOL of ENGINEERING

Technical Institute • College of Electrical Engineering

FREE—Write for "Occupational Guidance Manual" and 1951 Catalog.

MILWAUKEE SCHOOL OF ENGINEERING  
Dept. RN-551, 1020 N. Broadway  
Milwaukee, Wis.

Without obligation, mail Occupational Guidance Manual on:

- Radio-TV  Electrical Power  Welding  
 Heating, Refrigeration, Air Conditioning  
Also send 1951 Catalog for Electrical Engineering, B.S. degree in  Electric Power  Electronics

Name..... Age.....  
Address.....  
City..... Zone..... State.....

Check if World War II Veteran

petition in several markets and make available service to the public in those areas of the country that have been denied a television service, because of the color issue and the freeze. . . . Industry is prepared immediately to build stations in the very-high band, a limited amount of transmitting equipment is available, and receivers for this band at this band are not in short supply."

FCC Headman Coy, in a supplementary review of the educational aspect of the proposals, said that there is a startling lack of data concerning the willingness and readiness of educational institutions to use television as a tool. In his opinion, educational institutions will have to make up their minds in the reasonably near future . . . "as to whether or not they will utilize television in their educational program, and in so doing decide to become an operator or a joint operator of a non-commercial educational television station."

As this column is being written hundreds are preparing to testify for or against the allocation proposal, in a seething series of sessions. However, notwithstanding the rough program ahead with many scheduled to hammer away at the recommendations, a workable pattern will certainly present itself, with harmony on the look-and-hear lanes the theme of the plan.

**INDUSTRY'S ROLE IN COLOR TV.** on trial in the Supreme Court and for nearly a year a probe pet of Washington's seven airwave sheriffs, saw itself headlined, too, at the recent annual convention of the IRE in New York City, particularly during a rousing talk by RTMA's board chairman, Robert Sprague.

Stoutly defending the chassis makers, and especially the engineering fraternity, Sprague said: "I don't think that it is necessary for me or anyone else to come to the defense of the industry's engineers. Their record for more than a quarter of a century speaks for itself. However, I would like to take this opportunity to deny categorically the charges which have been hurled at our industry. . . . Engineers are highly individualistic persons who often do not agree with each other or their commercial colleagues. They are influenced in their decisions by facts and figures, and not by pressure from whatever source. . . . Our industry engineers generally strive to offer to the public the fruits of their technological developments at the lowest possible cost, but they seek to avoid foisting on the public either systems or equipment which have not been thoroughly tested."

Lashing out at FCC Commissioner Robert Jones, who in his color report rebuked industry and engineers calling them "unsound analysts," whose testimony was . . . "completely worthless"—because . . . "their economic interests blinded their engineering judgment" . . . Sprague said: "It is true that engineers are sometimes bru-



Comparison in size between the World War II walkie-talkie (left) and the new AN/PRC-10 model developed by RCA. The new unit is approximately half the size of the older unit and has greater coverage.

tally frank in expressing opinions, whether they speak as individuals or representatives of industry or engineering groups, but I think that any fair-minded person would concede that they are honest and fair in their ultimate judgments."

Describing the exhaustive efforts of industry to provide honest and sincere answers to problems, Sprague recalled the days of the first national television committee, formed as the result of a meeting between former FCC Chairman James Fly and Dr. W. R. G. Baker, director of engineering of RTMA and formerly prexy of the IRE. "The monumental work of that committee is a matter of record," declared Sprague, who added that in six months the committee developed standards and reported to the FCC.

Over 600,000 words were prepared for reports and 4000 man-hours devoted to meetings and an equal time to travel, the association head pointed out. As a result of this work, the standards for black and white television were proposed and television was off to a successful start.

"Perhaps the best measure of this almost unparalleled example of cooperation among engineers," reported Sprague, "is that several foreign countries have adopted television standards based upon those of the United States, with only minor variations."

Commenting on the color issues now being debated, Sprague declared that: "Much has been made of the fact that four of the NTSC committees were overwhelmingly in favor of color television as demonstrated by the CBS system. Overlooked, or at least under emphasized, are some of the other opinions expressed by these engineers at the same time. By substantial majorities, these engineers voted against adoption of color standards at that time, and expressed the belief that black and white standards should not be influenced by color television considerations."

The RTMA official's talk also disclosed the progress being achieved in the mobilization program. According to Sprague, military electronics production will reach a peak rate of \$2.5 billion in the fall of 1952 and there-

after will decline to an annual rate of \$1.5 billion. "In this connection," he said, "it should be borne in mind that military production dollars have about half the impact on our industry as civilian production dollars. This is for a variety of reasons, but particularly because a considerable portion of special and mechanical gear is obtained from manufacturers not generally considered as part of our industry. . . . These figures indicate that our industry will not be so heavily loaded with military contracts, but that it will be able to maintain a substantial amount of civilian production, even at the peak of the military output, except in the unfortunate event of an all-out war."

**THE "DO" RATINGS.** a priority term set up to assure speedy delivery to the armed services, have also become a true friend of the radio and TV part users. With DO-97 assigned to equipment and supplies for maintenance, repair and operation, there should be available a flow of the vital items necessary to keep those sets going.

Describing the new plan, Manly Fleischmann, administrator of the National Production Authority, said: "We cannot let the need for materials and equipment to build new facilities interfere with the maintenance of existing capacity. We can afford a few pounds of metal today to keep a machine running rather than several tons tomorrow to make a replacement machine. And in this way, we can avoid the loss of production and equipment that would result if we allowed our present equipment to fall into disrepair . . ."

Pointing out that it is imperative that the country's present production and service facilities be kept in good repair, Fleischmann said that it is . . . "vital that we maintain a strong civilian economy while we go ahead with the job of rearmament. . . . It is believed that the MRO (maintenance, repair, and operation) program will not interfere in any manner with the defense program, because the materials required constitute but a small percentage of the total supply."

**A NEW INFANTRY VERSION OF THE WALKIE-TALKIE.** one-half the size and weight and with twice the range of those used in World War II, demonstrated recently before members of the Signal Corps and other government agencies, will soon be on the way to our troops in Korea. Describing the production of the gear as a milestone in military communications, Major-General S. B. Aiken, Chief Signal Officer, said that the transmitter-receiver will help meet the problems of modern warfare and make it possible for the armored divisions, artillery, and infantry to keep in constant touch with each other, from point to point, even all the way back to the Pentagon, if that is necessary. . . . L.W.

May, 1951

### BC-223 TRANSMITTER



30 Watt transmitter with Crystal or MO control on four pre-selected channels. CW, NCW cover frequency range 2000-5200 KC. by use of plug-in coils. Complete with tubes and choice of one Tuning Unit (listed below). Less Mtg.—Price:

USED: **\$23.50**

CABLE—Trans. to Power Supply.....\$2.00  
TUNING UNITS: TU-17—2000-3000 KC.; TU-18—3000-4500 KC.; TU-25—3500-5250 KC. **\$3.50 EACH**  
SPARE TUBE KIT in metal box, f/BC-223...\$4.95  
OPERATING MANUAL for BC-223.....\$2.50  
PE-125 POWER SUPPLY f/BC-223—12/24 Volt input; output 500 Volt 150 MA. ....NEW: **\$11.95**  
SPARE VIBRATOR & TUBE KIT f/PE-125...\$4.95  
SHOCK MOUNTING for PE-125.....\$1.50

### BC-375—191 TUNING UNITS:

TUNING UNITS FOR BC-375 OR BC-191 TRANSMITTERS (Listed Below).....**\$3.95 EA.**  
TU-5—1500 to 3000 KC. TU-9 — 7700 to 10000 KC.  
TU-6—3000 to 4500 KC. TU-10 —10000 to 12500 KC.  
TU-7—4500 to 6200 KC. TU-26 — 200 to 500 KC.  
TU-8—6200 to 7700 KC. BC-306—Antenna Loading

### 3/4 RPM ANTENNA ROTATOR MOTOR

High torque, reversible motor—operates directly from 110 Volt 60 cycle by use of condenser. Light weight, quiet running. Ruggedly built, positive stop, easily mounted. Normally operates from 110 Volt 400 cycle. Complete—with instructions, NEW...**\$4.95**  
10 MFD 400 Volt Cond. **\$1.00**, SPST Momentary Switch, **35c**, DPDT Momentary Switch, **75c**, Resistor, 100 ohm 25 Watt, **50c**, 4 Wire Cable, **5c** per ft.



### AMPLIFIERS:

BC-605 AMPLIFIER—Ideal for conversion to Intercomm. set. Includes two 1619 Tubes, input and output Transformers, Volume Control, Jacks, Switch, and Schematic. Prices: NEW: **\$5.95** USED: **\$3.95**  
BC-709 AMPLIFIER—Portable, pocket size battery operated. Ideal for small planes, home, or portable use. Complete with 185 Tube, Jacks, etc. Less batteries. Prices: NEW: **\$3.95** USED: **\$2.95**  
BC-347 AMPLIFIER—Aircraft Type, contains 2 Midget UTC Converter Transformers, complete with 6F8 Tube. NEW.....**\$2.95**

OUTDOOR SPEAKER—Navy Type MI-2917J, Metal Housing 10". Speaker size 5 1/2". With Heavy PM Slug and Line Matching Transformer. USED—Tested.....**\$8.95**

### BLOWERS:

115 Volt 60 cycle BLOWER (pictured), approx. 100 CFM Dis. 2 1/4" intake; 2" outlet. Quiet running. Motor size: 2 1/2" x 3 1/4". NEW—not Gov't surplus. Order No. RN-520...**\$7.99**



DUAL BLOWER—Same as RN-520 above, except has blower assembly on each side of motor. Order No. RN-800.....**\$12.95**

L-R #2 Blower Assembly, Plastic Housing 3"x1 1/2". Blower Wheel 2"x1"—1/4" shaft. (No Motor)...**\$1.95**  
L-R #2 1/2—Same as above, Housing 3 1/2"x1 1/2"...**\$2.00**  
L-R Blower Wheel only, 3"x2"—3/8" shaft...**\$1.00**

### 6-VOLT POWER SUPPLY

VIBRATOR TYPE—6 Volt DC input; output 230 Volt DC 50 MA, filtered w/tube. Size: 6 1/2"x4"x5 1/2". Price.....**\$6.95**

VIBRATOR TYPE—6 Volt DC input; output 230 Volt DC 50 MA.—not filtered—w/tube. Ideal for Command Receiver operation as receiver is filtered internally. Size: 4 1/2"x4 1/4"x3 1/2".....**\$4.95**  
PE-104 Converter for BC-654 Transceiver...**\$15.00**



### GEAR TRAIN MOTOR

Ball bearing, low inertia reversible type motor, 588 RPM. Low speed gear 14 RPM. Extra large Gear 7/8 RPM. Operates 26 V. 400 cycle or 12 V. 60 cycle. Price—each—**\$2.95** only.....

### AERIAL WIRE:

Aerial Wire Phosphorous Bronze #16 Stranded. 200 lb. test. Weather-proof. 150 Feet on Reel RL-3 w/clips...**\$1.50**

### RG-8/U COAXIAL CABLE

(W/PL-259 Plugs, ea. end):  
65 Foot length...**\$4.95**  
50 Foot length...**3.95**  
30 Foot length...**2.50**

Address Dept. RN • Minimum Order \$2.00 • Prices F.O.B., Lima • 25% Deposit on C.O.D. Orders

# FAIR RADIO SALES

132 SOUTH MAIN ST. LIMA, OHIO

### RECEIVER (MOBILE-BOAT-AIRCRAFT)

BENDIX RA-10 RECEIVER—8 Tube Set covering frequency range 150 to 1100 KC. and 2000 to 10000 KC. in four bands by use of remote control unit. Set size: 18 1/2" L. x 10 1/2" W. x 8 3/4" H. Wt. 32 1/2 lbs. Comes complete with remote control unit, dynamotor, and plugs. BRAND NEW. Order RA-10 CA f/ 14 Volt DC operation. **\$49.95**  
Order RA-10 DA f/ 28 Volt DC operation.

### HIGH VOLTAGE POWER SUPPLY

PM Field Dynamotor Supply, 12 or 24 Volt DC input; 500 Volt 50 MA and 275 Volt 110 MA output. Complete with hash filters, separate fuse for each output. Contains two separate dynamotors for the above output; also on and off switch, indicator light, switching relay, receptacles, etc. Heavy gauge metal case, size: 8 3/4" x 6 1/4" x 11 1/2". Used on No. 19 Mark II Radio Set. Shipping Weight: 62 lbs. Price.....Ea. **\$7.95**  
Metal Case and Punched Front Panel only **\$2.00**



### TRANSFORMERS 110 V. 60 CYCLE PRIMARIES:

SEC.:  
24 V. 1/2 amp. **\$1.50**  
24 V. 4 1/2 amps. **3.95**  
12 V. 4 amps. **3.95**  
36 V. 4 amps. **3.95**

### WIRE—HEAVY DUTY RUBBER COVERED:

2/#16 .....20' **\$1.25**  
2/#12 .....10' **1.00**  
1/#6 Shield. 15' **1.50**  
1/#6 Shield. 7 1/2' **.75**

### GASOLINE ENGINE GENERATOR

HOMELITE Gasoline Engine Generator—30 Volt DC 50 ampere (1500 Watts) generator driven by single cylinder, two cycle air-cooled gas engine approx. 3 HP. Rope or electric starting. From unused Govt. vehicles, reconditioned. Shipping Wt. 150 lbs. **\$59.50**  
Price.....

### DYNAMOTORS:

INPUT	OUTPUT	STOCK No.	PRICE
12 V. DC	220 V. 70 MA.	DM-24	<b>\$6.95</b>
12 V. DC	220 V. 100 MA.	DM-18	<b>4.95</b>
12 or 24 V. DC	440 V. 200 MA. & 220 V. 100 MA.	D-104	<b>9.95</b>
12 V. DC	600 V. 300 MA.	BD-86	<b>7.95</b>
12 V. DC	330 V. 150 MA.	BD-87	<b>5.95</b>
12 V. DC	375 V. 150 MA.	BD-83	<b>6.95</b>
12 V. DC	1000 V. 300 MA.	BD-77	<b>7.95</b>

PERMANENT MAGNET FIELD DYNAMOTORS:  
12 or 24 V. DC 275 V. 110 MA. USA/6516 **\$3.95**  
12 or 24 V. DC 500 V. 50 MA. USA/0515 **2.95**  
@ 6 V. DC 240 V. 50 MA.

Tell Us Your Dynamotor, Inverter, & Motor Needs!

### GUY CABLE

Regular Aircraft Control Cable, 3/32"—7x7—49 Strands galvanized weatherproof. 320 lb. Test. Ideal for television or radio mast guying. Prices:  
**2 1/2c per Ft.—1000 Ft. or more: 2 1/2c per Ft.**

### WHIP ANTENNA EQUIPMENT

#### MAST BASES—INSULATED:

MP-48 Base (Illustrated at right) Insulated type with heavy coil spring. Requires 1 1/2" mounting hole. Weight: 11 lbs. Price.....**\$4.95**

MP-132 Base (Illustrated at left) 1" heavy coil spring. 2" insulator. Overall length: 11 1/2". Weight: 2 1/2 lbs. Price.....**\$3.95**

MP-22 Base—Spring action direction of bracket. 4" x 6" mounting. Price....**\$2.95**

#### MAST SECTIONS FOR ABOVE BASES:

Tubular steel, copper coated, painted, in 3 foot sections, screw-in type. MS-53 can be used to make any length, with MS-52-51-50-49 for taper. Price, each, for any section.....(Ea.) **50c**  
MS-54—Larger section than MS-53.....**75c**  
BAG BG-56 for carrying 5 Mast Sections.....**50c**

#### MAY SPECIALS:

TA-12B Transmitter, Good, Used w/Tubes...**\$29.95**  
RA-10A Rec. 12 Volt, Good, Used w/Tubes...**17.95**  
RA-10B Rec. 24 Volt, Good, Used w/Tubes...**17.95**  
BC-604 Transmitter, Good, Used w/Tubes...**19.95**  
MN-200 Compass Receiver, 150-1500 KC....**29.95**  
PL-8 Filter, 1020 cycle Audio Filter, Used...**1.50**  
T-17 Microphone, Carbon w/Cord & Plug, Used...**1.00**  
116/U Headset w/Cord and Plug, Used...**1.50**  
Leg & Seat Assembly for Hand Generators...**3.50**  
CD-501 Cord for GN-45 Generator.....**2.00**

# CONCORD SCOOP!



SAVE 50%  
ON THIS  
FM  
TUNER  
**995**  
Your Net

Enjoy clear, static-free reception of your favorite music and sports events--convert to FM for less than \$10.00 with this Exclusive Concord FM tuner. Easily converts any AM receiver, phono amplifier or PA system for FM. Covers the entire 88-108 FM band. Tuning and on-off controls on front panel with terminals for connection of 300 ohm twin lead antenna on back. Extremely easy to install... Uses a 7F8 in a fremodyne circuit, plus a 6H6 rectifier. Size of chassis: 6-3/4 x 4 x 4-1/8". Complete with tubes. For 110-120 volts, AC-DC. 9v-9502R--Shpg. Wt. 2 lbs. .... Net. .... 9 95

DUAL  
VIBRATOR  
POWER  
PACK  
**995**  
Your Net



Another Special Concord Exclusive!... Selling at a fraction of its original cost. Brand new vibrator power supply... ideal for mobile amateur rigs (transmitter & receiver) or mobile Public Address systems. Compactly designed cabinet can be easily mounted under auto dashboards. Two vibrators supply dual output: 400 volts at 150 ma; 225 volts at 60 ma with slight modification. Enclosed terminal board provides lugs for connecting handset, microphone, and speaker. Unit also has provisions for mounting speaker inside. Controls on front panel include: channel selector, on-off switch, squelch control (cuts out all noise when no signal is being received), and volume control. Supplied with instructions for modification but less vibrators. Size: 6-5/8 x 6 x 5-1/8". 99-9627R--Shpg. Wt. 9 lbs. .... Net. .... 9 95

Kit of 2 vibrators and vibrator socket for modification of above unit. 99-3957R--Shpg. Wt. 1 lb. .... Net. .... 5 79

THOUSANDS  
OF SIMILAR BARGAINS  
ARE YOURS AT

**CONCORD RADIO**  
SEND FOR LATEST  
BUYER'S GUIDE

FILL IN AND MAIL TODAY

CONCORD RADIO CORP. Dept. RE-51  
901 West Jackson Blvd., Chicago 7, Illinois

Enclosed \$..... (Include shipping charge.  
Any excess will be refunded.) Rush me the  
following equipment.

- 99-9502R FM Converter \$9.95
- 99-9627R Vibrator Power Pack \$9.95
- 99-3957R Vibrator Kit \$5.79
- Send FREE latest Buyer's Guide

Name.....

Address.....

City..... Zone..... State.....

## What's New in Radio (Continued from page 80)

new unit is called the "Civil Defender."

Designed to be used by police agencies, fire departments, water departments, the Red Cross, highway maintenance departments, power companies, and other groups comprising the civil defense organization, the new receiver permits civil defense headquarters to broadcast messages to all groups at once or to separate groups individually. Thus a group hears only messages it is intended to receive. Each receiver is inactive until turned on by headquarters.

In addition to receiving messages, the unit can also be used to automatically start and stop air raid sirens or other warning devices. The push of a button at headquarters broadcasts a special tone which, when received by the set, operates a switch to activate the warning device system.

Full details on the new receiver are available from the company.

### COMPACT SCOPE

The Simpson Electric Company of 5200 W. Kinzie Street, Chicago, Illinois is currently in production on a new model oscilloscope which is designed to save space on the test bench.

Designated the Model 476 "Mirror-scope," the new unit uses a 5" cathode-ray tube mounted in the vertical position. This type of construction reduces bench requirements to an area of 9" x 8". The cathode-ray image is reflected from a mirror mounted in the adjustable cover at the top of the cabinet. In this way the viewing surface is brought near the eye level when the instrument is used on benches of nor-



mal height. The mirror and wing sides at the top for deflecting light fold into the cabinet when not in use.

A high frequency crystal probe is available for use with this scope at an additional charge.

### NEW TUBE CAP

Alden Products Company of 117 N. Main Street, Brockton, Massachusetts has announced a new high voltage, low-loss tube cap for use in miniature tube applications.

## OUTSTANDING - TV - VALUES

**MODEL #300**  
Folded dipole complete with reflector and high frequency adapter. Covers 13 channels. All alum. construction. Less mast. Shpg. wt. 7 lbs. PRICE ..... \$4.50

**MODEL #200-D**  
Stacked array. Consists of 2 complete conicals and connecting bars. Very rigid construction. Covers all 13 channels. Matches 300 Ohm or 72 Ohm. Center impedance 150 Ohm. Ideal for low signal areas. An outstanding buy. Shpg. wt. 12 lbs. SENSATIONAL \$8.40 OFFER at less mast.

**MODEL #200-S**  
Single array. Same construction as above. Shpg. wt. 12 lbs. Price, less mast. .... \$3.95

**MODEL #500**  
All-band folded dipole antenna. Maximum gain on any channel. Alum. construction. Less mast. Shpg. wt. 8 lbs. Price..... \$5.25

**MODEL #Y-100**  
5 element Yagi Hi-Gain beam designed specifically for fringe area use. All alum. construction. Cut to specific channels. Shpg. wt. 4 lbs. Channel #7. \$5.80; Channel #9. \$5.20; Channel #11. \$4.60; and Channel #13. \$4.00. The prices are less mast. "Y" type antenna. Price \$4.25

**FULLY AUTOMATIC BOOSTER**--automatic on-off, automatic tuning, concealed installation, single or dual input, full band width on all channels, high uniform gain, 19 db on low 2-6, FM and 14 db on high 7-13. Specially priced..... \$29.95

**ANTENNA ACCESSORIES**

- CM-100 Chimney Mount..... \$ 1.50
- WM-104 Wall Mount 4"..... .98
- WM-107 Wall Mount 7"..... 1.25
- U-100 Universal Ant. Mtk. Bkt. Offset to 9" Price..... 3.95
- U-200 Same as U-100 but Offset to 12" Price..... 6.95
- 3 1/2" 300-ohm stand-off insulators fit coax cable. Per 100, \$3.00; per 500, \$12.00; per 1000, 20.00
- Best Quality 300-ohm twin lead--Send for prices.
- High Quality 72-ohm Coax Cable--Send for prices.
- Folded Dipole Hi-Frequency Adapters..... 1.50
- Straight Dipole Hi-Frequency Adapters..... 1.50

**TERMS:** All shipments F.O.B. Newark, New Jersey. 25% deposit with orders, balance C.O.D. Minimum order \$2.00. Include ample postage. Prices Subject to Change Without Notice

**EAST COAST ELECTRONICS**  
39 George St. Dept. 5-N Newark 5, New Jersey

## THE WORLD'S LEADING TWIN LEAD TELEVISION LIGHTNING ARRESTER



completely waterproof

## SAFE TV GUARD

Protects television sets against lightning and static charges. Simple to install everywhere and anywhere... no stripping, cutting or spreading of wires. More than 500,000 in use today!

See your jobber or write to --

**JFD MANUFACTURING CO., INC.**  
6105-E 16th Ave., Brooklyn 4, New York  
FIRST in Television Antennas and Accessories

The tube cap in which the wire insulation and long skirted grid cap insulation is molded in polyethylene as one homogeneous unit, is designed to be used with a 1X2 tube or tubes of

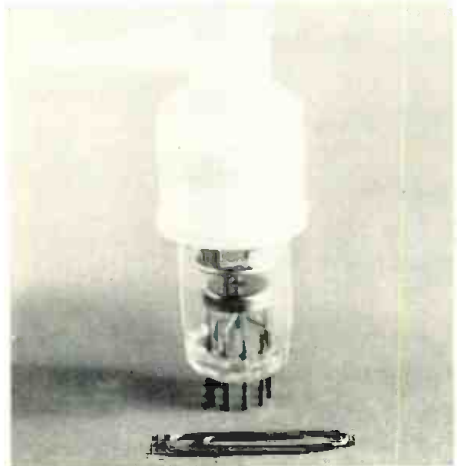

similar physical dimensions. The 90 ISTL unit has a long skirt that prevents danger of flashover from grid cap to chassis when operated at high voltages. The wire and grid cap molded as one unit gives positive strain relief of leads against vibration, twisting or strain and gives 100% insulation.

For critical operations at extremely high temperatures the 90 ISTL can be molded in "Kel-F."

Complete details are available from the company. Address your requests to the attention of Norman Curtis.

#### SUBMINIATURE CONDENSERS

*Sprague Electric Company* of North Adams, Massachusetts has developed a complete line of subminiature condensers and a new technique for mounting such units.

The new 125 degree C units are available as hermetically-sealed, tiny threaded-neck, side-stud and end-stud condensers as well as in vertical and horizontal bracket mounting units. These new mounting arrangements are designed to help overcome vibration and shock problems encountered when mounting condensers by wire leads in military gear.

The units are available in voltage ratings from 100 to 1000 volts d.c. in both inserted tab and extended foil constructions.

Engineering details on the new condensers are contained in the company's Bulletin 213A which is available to those making the request on their company letterheads.

#### BASS REFLEX CABINET

*Standard Wood Products Corp.*, 43-02 38th Street, Long Island City 4, New York has a new model bass reflex cabinet available for 15" and 12" speakers.

The Model RX combines the latest acoustic engineering principles with authentic furniture styling. The cabinets feature wide frequency response, high power handling capacity, and wide angle distribution.

Construction throughout is non-vibratory. Interior acoustic padding



## 30-TUBE 630 TV CHASSIS

Takes All Picture Tubes to 24"  
ROUND or RECTANGULAR—Lic. by RCA

This QUALITY CHASSIS incorporates ALL the SUPERIOR FEATURES and ENGINEERING ADVANCEMENTS that have been made up to date! Unexcelled for fringe area reception, it gives superior definition and better picture contrast because of its precision factory alignment. Keyed AGC—complete noise immunity; FM traps; 15 KV under normal picture load; full 4 megacycle overall picture band width.

Factory aligned, ready-to-play, less CR tube

**\$169<sup>50</sup>\***

Complete with 12" RCA SPEAKER

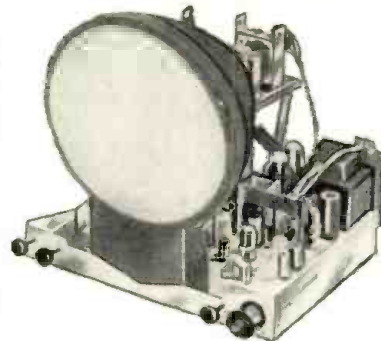

AVAILABLE WITH

NEW

**DUMONT INPUTUNER \$179<sup>50</sup>\***  
covering FM BANDS

\* PRICES INCLUDE ALL EXCISE TAXES

Series T-3A

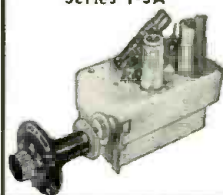

**DUMONT 4-CIRCUIT INPUTUNER**

Featuring FM BAND reception, as well as 13 TV channels. Fits into dual channel IF system Type 630 receivers without alteration. Higher gain 2-1 ratio on high channels, low noise, input impedance 300 ohms. 21.25 mcs. sound center IF. Continuous tuning. Complete with TUBES and KNOBS. .... **\$23<sup>95</sup>**

**Cathode Ray Tubes**  
(All Black Face)

**20" \$59<sup>95</sup>**

RECTANGULAR

12 1/2" round... \$26.25  
14" rectangular... 27.95  
16" round... 37.95  
16" rectangular... 38.95  
17" rectangular... 39.95  
19" round... 67.50  
24" round... 115.00

All tubes fully guaranteed. RCA, Dumont, Tel-O-Tube, etc.

#### McMURDO SILVER FM & TV SWEEP SIGNAL GENERATORS

SAVE \$25



NOT A KIT—But a

Precision Assembled Instrument

Model 911

Reg. net dealer price \$78.50

Our Price **\$53<sup>95</sup>**

Designed specifically for visual alignment, using any good oscilloscope of wide band IF and RF amplifiers as found in FM and TV receivers. Has two separate amplitude-variable "marker oscillators" or "pipers" essential to correct alignment of TV receiver video IF amplifiers. Phasing control is provided. Frequency range 2 to 22.5 mc. in 3 ranges. 5" diameter 10:1 Vernier driven dial directly calibrated in frequency to ± 1% accuracy. Output Voltage: Variable from substantially zero to 1 volt maximum. Output Impedance: Variable 5 through 125 ohms. FM Sweep: Variable from substantially zero to over 10 mc. Marker Oscillator: Low drift ultra-stable AT cut crystal oscillators built-in, precisely adjusted to 1 and 5 mcs. respectively. Maximum amplitude to provide "pip" magnitude. Marker oscillator harmonics on the 1 mc. oscillator useful to 30 mcs.; the 5 mc. oscillator useful to 100 mcs. and above.

SAVE \$15 on Model 909

Designed with the same features as Model 911 with the exception of the two separate amplitude variable "marker oscillators" or "pipers" which are not required in routine FM receiver or TV sound channel IF realignment. Reg. Net Dealer Price \$48.50 Our Price **\$33.50**

A COMPLETE INSTRUMENT—NOT A KIT!

5" OSCILLOSCOPE

HIGH GAIN—WIDE BAND  
Regular Value \$279

BRAND NEW LIMITED QUANTITY **\$129<sup>50</sup>**



Made by a Famous Manufacturer

FEATURES:

- ± 1: Vertical Bandwidth 10 Cy to 2 Mc., 3 db down
- ± 2: Vertical Sensitivity .06 RMS volts/inch
- ± 3: Decade Type Frequency Compensated Attenuators
- ± 4: Horizontal Bandwidth 2 Cy to 900 KC-6db down
- ± 5: Horizontal Sensitivity .15 RMS volts/inch
- ± 6: Push Pull Deflection Amplifiers
- ± 7: Direct Connection to Deflection Plates Available
- ± 8: Internal Synchronization of Either Polarity
- ± 9: Z Axis Input (Intensity Modulation)
- ± 10: Calibrated 60 Cy Test Signal

Tube Complement: 2-6AG7, 3-6SN7, 1-6AC7, 1-5Y3, 1-2X2, 1-884, 1-5CP1

#### BARGAIN SPECIALS—

While They Last!

Rush Your Order Now!

	Our Price
RMS All-Channel Booster, List \$43.95	\$19.95
High Voltage Single 1B3 rectifier, Flyback Transformer 14.5 KV with schematic for 20" tube	4.95
RCA Type 211T5 Flyback Voltage Doubler	3.95
RCA Type 211T2 Flyback for Projection TV 27.5 KV	5.95
Indoor TV Antenna	2.95
All-Channel Conical Aluminum Antenna	4.95
Conical Window Antenna, High Gain	5.95
Pistol-Grip Soldering Gun, 75w.	\$2.95 100w. 3.95

#### DYNAMOTORS

##### PIONEER GEN-E-MOTOR

Type E-3: Input 14 VDC @ 8 amps DC. Output 550 V @ 120 mils. ...	\$14.95
SP-125: Input 28 VDC @ 2.2 amps DC. Output 270 V @ 120 mils. ...	\$6.95
DS-125: Input 28 VDC @ 1.2 amps DC. Output 260 V @ 60 mils. ...	\$4.95
Type DA-1A: Input 28 VDC @ 1.6 amps DC. Output 230V @ 100 mils. ...	\$5.95

##### Carter Genemotor

Stock No. 4037AS  
DC Input 6VDC; output 400 V @ 375 mils DC. Perfect for mobile communications in car, plane or boat.  
IRLAND NEW  
List \$71.40  
Our Price **\$34.95**

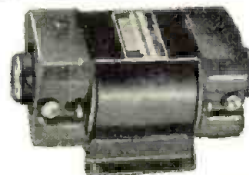

Phone WOrth 4-3270

#### ACORN ELECTRONICS CORP.

76 Vesey St., Dept. N-5, New York 7, N. Y.

TERMS: 20% cash with order, balance C.O.D. unless rated. All prices F.O.B. our warehouse in N. Y. C. Minimum order \$5. NOTE: Due to conditions beyond our control, prices are subject to change.

# SERVICE-MEN!

**R**EEVES Soundcraft Laboratories afford you the best in television picture tubes at prices consistent with such quality. When replacement requirements dictate the need for high efficiency and fidelity, Reeves products are the answer. Experienced service-men have found that they always result in satisfied customers — and a profitable service operation.



Soundcraft rectangular television tubes are available in 16", 17" and 20" sizes. You can use and recommend them with assurance because they are backed by the greater integrity and experience of the Reeves name, a foremost manufacturer in the electronics and recording field throughout the country for twenty years.

**REEVES**  
*Soundcraft*  
**CORP.**



TWENTY YEARS OF LEADERSHIP IN SOUND ELECTRONICS  
10 EAST 52nd STREET, NEW YORK 22, N. Y.  
EXPORT—REEVES EQUIPMENT CORPORATION  
10 EAST 52nd STREET, NEW YORK 22, N. Y.

eliminates all internal sound reflections. Capacity of the unit is 10,000 cubic inches and the plywood baffle and back are easily removable. The baffle-board is cut out for 15" or 12" speakers



and is already mounted and equipped with speaker mounting bolts. To vary the size of the port opening, the baffle-board is adjustable.

The cabinet is available in mahogany, cordovan mahogany, walnut, ebony, and blonde finishes and measures 36" high, 16" deep, and 24" wide.

## TURNER MIKE

The *Turner Company* of 900 17th Street, N.E., Cedar Rapids, Iowa, is now in production on a new crystal microphone, the "Competitor."

Catalogued as the Model 60X, the new unit is designed for hams, economical p.a. and sound systems, and other applications where good speech reproduction is required and cost is a factor.

The mike is housed in an attractive case finished in baked-on beige wrinkle finish enamel and comes complete with a six-foot cable and stand adapter.

Response is 70 to 7000 c.p.s. with a level of 52 db. below 1 volt/dyne/sq.



cm. The crystal is moisture sealed. The unit is available with an "on-off" slide switch.

Full details are available on request.

## PRECISION POT

In response to the growing demand for precision-built parts for use in critical electronic assemblies, *Claro-stat Mfg. Co., Inc.* of Dover, New Hampshire has announced the devel-

opment of a special precision potentiometer for such applications.

The new control, which is being produced on a custom basis, has a tapered winding held to a tolerance of  $\pm 1\frac{1}{2}\%$  linearity as measured at ten test points. Mechanical tolerances are held as close as  $\pm .00025$  inch. Designed to operate over extreme ranges of temperature, humidity, altitude or barometric pressure and under severe vibration, the new component is also treated to meet fungus and corrosive conditions.

The body of this special control is molded in yellow or low-loss bakelite. Positive low-loss conductivity is assured by the silver contact carried by the ring-shaped slider which rides the winding as well as the contact rail. A slip-on black plastic cap protects the control mechanism.

## FM TUNER

The *Gonset Company* of Burbank, California has just announced a new FM communications tuner designed for ultra-high frequency reception.

The tuner is available in several frequency ranges and is especially suited



for reception of police, fire, taxicab, aircraft, civilian defense, and other such services. Among the frequency ranges available are 152-162 mc.

The entire unit is housed in a compact box which measures  $5\frac{1}{4}$ " x  $3\frac{1}{2}$ " x  $5\frac{1}{4}$ ".

A descriptive bulletin on the new unit is available from the company.

## HANDY NEW TOOL

*Drilsaw Co.* of 1561 Virginia Avenue, Glendale 2, California has introduced a new combination drill and saw unit which is unique in design and applicable to many jobs in the radio or television service shop.

The blade is made of steel and is set immovably in a lacquered hardwood handle. The tip of the blade is a fast boring gimlet. The main portion of the blade is sharply toothed spirally so that the tool saws rapidly in any direction after drilling its own hole.

The tool will handle plywood, hardwood, plaster, and wallboards and is especially useful in cutting regular and irregular holes for receptacles, switch boxes, etc.

Complete details and prices are available from the company.

## SLUG-TUNED COIL FORM

*Cambridge Thermionic Corporation*, 463 Concord Avenue, Cambridge 38, Massachusetts is currently offering a

**RADIO & TELEVISION NEWS**

new slug-tuned coil form that features silver plated phosphor bronze clip terminals which cannot loosen.

The Type LS-8 measures 23/32" high, and 1/2" maximum diameter. The unit mounts in a "D" punched hole or in a 1/4" round hole. The coil form is made of grade L-5 silicone impregnated ceramic. The slug is provided with a spring lock. All metallic parts except the clips

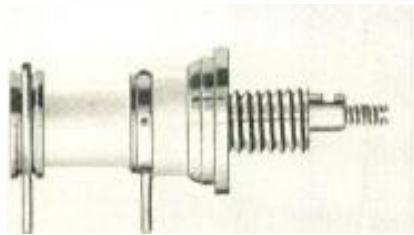

are cadmium plated to insure long-life service.

The LS-8 comes complete with slug and all of the necessary mounting hardware.

#### MOBILE RADIOTELEPHONE

The *Kaar Engineering Company*, Middlefield Road, Palo Alto, California has recently announced the availability of a new single unit transmitter-receiver for mobile communication in the 152-174 mc. band. The new model has been tradenamed the "Radiopak."

The new unit is completely integrated for simplicity of installation, maintenance, and operation and features improved stability and sensitivity while its engineered selectivity exceeds the standards set by FCC regulations.

Power output of the new unit is 10-12 watts with a battery drain of 6 1/2 amperes during standby periods and 15 amperes during transmission. The equipment will operate from the regular 6 volt vehicular electrical system. Overall measurements are 6 3/4" high, 8" wide, and 18 1/8" long. The unit weighs 24 lbs. including the dust cover.

Complete technical data on the "Radiopak" is available from the company. -30-

## Opportunities for FIELD SERVICE ENGINEERS

If you know electronics, like to travel, like to fly, there's a place for you as a Field Service Representative in the expanding Aeronautical Division of Minneapolis-Honeywell.

Thorough training in the theory and application of electronics is a prerequisite to these jobs. Although an electrical engineering degree is desirable, it's not essential if you've gained an equivalent background through practical experience. As a Field Service Representative you'll have the opportunity to travel extensively and will gain valuable flying experience in commercial and military aircraft. The ability to work effectively with people is an essential factor.

For additional information regarding opportunities, write giving full particulars, to:

A. C. Klevickis, Personnel Dept. "B"

**MINNEAPOLIS  
Honeywell**

2753 FOURTH AVENUE S.  
MINNEAPOLIS 8, MINN.

JOE B. HIGGINBOTHAM, JR.

Nubers, Ga.

**THANKS,  
Mr. Higginbotham!**

Radio Receptor Co., Inc.  
West 19th Street  
New York 11, N.Y.

Gentlemen:

Please send me your pamphlet on the design, application and servicing of selenium rectifiers.

Although I have serviced many receivers which have selenium rectifiers I have very little information on them and believe your pamphlet would be a valuable asset to my shop.

I use your rectifiers, supplied by Southeastern Radio Parts Co. and Specialty Distributing Co. of Atlanta, Ga., and like them very much. Also I appreciate your consideration of the radio repairman in that you supply a data sheet with each rectifier and the trouble taken to print the servicing information.

Yours Truly

*Joe B. Higginbotham Jr.*  
Joe B. Higginbotham Jr.



SELETRON RECTIFIERS



And our thanks go as well to the other thousands of servicemen and hams who insist upon top performing SELETRON Selenium Rectifiers in electronic circuits and as replacements in Radio and TV sets.

You can depend on SELETRON all ways... Full technical information is always available without obligation. Look for Howard W. Sam's Red Book Supplement listing SELETRON replacements, and write us for Bulletin No. TN-6

SELETRON DIVISION  
**RADIO RECEPTOR COMPANY, INC.**  
Since 1922 in Radio and Electronics  
Factory: 84 North 5th St., Brooklyn 11, N. Y. • Sales Department: 251 West 19th St., New York 11, N. Y.

# SAVE

THAT GOOD LOOKING OLD CONSOLE—  
REPLACE YOUR OBSOLETE RADIO

with a modern, easily installed

## ESPEY AM/FM CHASSIS

and your favorite console is "right-up-to-date"



Rated an excellent instrument by America's foremost electronic engineers. Fully licensed under RCA and Hazeltine patents. The photo shows the Espey Model 511-B, supplied ready to play. Equipped with tubes, antenna, speaker, and all necessary hardware for mounting.

**NEW FEATURES**—Improved frequency modulation circuit, drift compensated • 12 tubes plus rectifier, electronic tuning eye and pre-amplifier pick-up tubes • 4 dual purpose tubes • High quality AM-FM reception • Push-pull beam power audio output 10 watts • Switch for easy changing to crystal or variable reluctance pick-ups • Multi-tap audio output transformer supplying 4—8—500 ohms.

Makers of fine radios since 1928.

Write for literature RN for complete specifications on Model 511-B and others.

**ESPEY**  
TEL. TRofalgar 1-7000  
**MANUFACTURING COMPANY, INC.**

528 EAST 72nd STREET, NEW YORK 21, N. Y.

# MOBILE ANTENNA KIT

152-162MC

ATTENTION! Cab Co., Police & Fire Depts., Utilities, Govt. & Civilian Defense Agencies, GE Model 4EY1C1 Antenna Kit, consist of 1 ea. 18 1/2" Dipole, 12 ft. RG-8-U Co-ax Cable, RF Antenna, Coaxial Plug, 259 Coax. & Installation hardware. Can be cut for higher freq. **\$4.95**  
New, Individually Boxed ..... ea.  
10 for **\$45.00**

**SPECIAL DELUXE KIT**, as above, but includes Allied Control 1 8VDC SPDT Co-ax Relay ..... **\$9.50**  
83-181N Co-ax Connectors ..... 2 for **.99**

### METERS

Matched pair of 2 1/2" Sq. D.C. Meters, 0-9V, 0-100 Amp. with Shunt, Combination, only **\$2.49**  
0-5 MA 3" Round (SP Scale) ..... **2.95**

New Steel Table Rack Cabinets, 8 1/2"H x 10"W x 13"D, Black Crackle Finish, Hinged Top with Lock, 2" opening in rear for cable connections, etc. .... **\$5.95**  
8 1/2" x 10" Relay Rack Panel (Aluminum) ..... **2.59**

### TV COMPONENTS

Ion Traps (Beam Benders), Double Type, can be cut in two & used sep., -89c ea. 2 for **\$0.99**  
Closest Ion Trap, Adj. Vernier Ring ..... **.85**  
Ram Fly Back Trans., Volt for 16" CRT ..... **3.95**  
Ram Fly Back Trans., Volt for 20" CRT ..... **4.95**  
Focus Coil up to 14 CRT, 400 Ohm ..... **2.90**  
Focus Coil up to 14" CRT, 475 Ohm ..... **3.25**  
CRL Hycap .0005MF 20KV Capacitors ..... **.85**

Set of Two Powerful Cobalt Magnets, Brass Cont. housed in wooden box, ideal for Schools, Labs., etc. .... **\$1.75 set 10 sets for \$15.00**

### COMPONENT BARGAINS

5 Screw Term. Strip (1/32 Screw) .10 for **\$1.20**  
Barrier Strip Yellow (1/16" Term.) .10 for **1.50**  
5 Way Binding Post, Red or Black ..... **.40**  
Octal Sock., MIP, Mica Filled ..... **1.00**  
7 1/2" Plated Knob, brass-inser. 1/4" for **1.25**  
Dual 10Amp. 15V. 60cy. Circuit Breaker ..... **2.95**  
.03MF 400V Metal Cased Oil Tub. Cap. 10/ ..... **1.99**  
.1MF 600V Metal Cased Oil Tub. Cap. 10/ ..... **2.49**  
.5MF 600V Metal Cased Oil Tub. Cap. 10/ ..... **4.50**  
1 x .1MF 600V Aerosol Bath-Tub St. 10/ ..... **5.00**  
5 x .5MF 600V C-D Bath-Tub St. 10/ ..... **9.99**  
1MF 600V Bath-Tub St. 10/ ..... **9.99**  
1 x 1MF 200V Bath-Tub St. .... **.75**  
2MF 600V Bath-Tub St. .... **1.25**  
4MF 150VAC GE Oil Cap. .... **1.99**  
4MF 600V C-D Oil Cap TQ Type ..... **5/**  
7MF 600V Oil ..... **1.49**  
8 x 8MF 600V Oil ..... **1.95**  
C-D 100MF 50V Electrolytic Cap. .... **5/**  
20MF 50V Bath-Tub Electro. Cap. St. .... **1.67**  
1MF 400V aerosol. 484 Tub. Cap. 10/ ..... **2.40**  
Muter KN136B 2-MMF Var. Cap. 10/ ..... **.99**  
.01MF 600V Trans. Mica Cap. .... **.80**  
.01MF 1200V Trans. Mica Cap. .... **.99**  
.003MF 2500V Trans. Mica Cap. .... **.99**  
.005MF 2500V Trans. Mica Cap. .... **.99**  
.002MF 3800V Trans. Mica Cap. 9/ ..... **1.99**  
Four Quadrant Phase Shift Cap. .... **3.50**  
SPH Luminous Tip Hat Handle Aircraft Torg. SW. 8PDT 1A 125 V 10 for **1.95**  
SPRT As Above ..... **10 for 1.95**  
SPST As Above, momentary only ..... **.25**  
SPDT AS ABOVE, neutral center ..... **4.95**  
Cramer Time Delay Relay, 120 Sec 120 VAC ..... **9.95**  
Pot-Bron. Type St. Relay, 6 VAC, DPST ..... **1.95**  
1000KC Xtal \$2.25 5VC Xtal 60 CY ..... **6.95**  
Precision 100KC Xtal ..... **6.95**  
12HY 160 MA CHOKES \$1.25 ea. 2 for ..... **1.98**  
80LA Constant Volt. Trans. Mica Cap. 60 CY ..... **39.50**  
Out. 115 V 250VA ..... **39.50**  
Wagner Tube Heaters 110 V 100 W. 2 5/16" Inside Diameter 2 for ..... **3.90**  
IRC 50K 100W fixed, 2.5K 100W ADJ. Pr. 1.25  
Rheostat-50 ohm 25W, 100 ohm 25W, ea.  
Counter, Type Instrum. Mica Cap. 3/4" 1/2" to 1/4" Shaft, 3 Digit Counter ..... **1.95**  
Pilot Light Assembly, Potiorod Dimmer type, Red, Green, Amber, White ..... **.24**

### CHOKES

0 HY 65 MA ..... 2 for **.99**  
10 HY 80 MA 240 OHM ..... **2.89**  
20 HY 100 MA 400 OHM Herm. Seal. .... **2.00**  
7 HY 125 MA Cased ..... **\$1.10 ea. 2/**  
10 HY 150 MA 140 OHM ..... **1.69**  
7 HY 200MA 100 OHM, Cased ..... **3.49**  
4-10 HY 200 MA 140 OHM Swinging CH. .... **4.25**  
3 HY 250 MA 15 OHM Herm. Seal. .... **2.45**  
15 HY 250 MA 60 OHM, Cased ..... **3.49**  
3-4 HY 300 MA 80 OHM Swinging CH. .... **6.20**  
6 HY 300 MA 65 OHM, Cased ..... **6.10**  
8 HY 300 MA 80 OHM, Cased ..... **6.10**  
6 HY 350 MA 72 OHM, Cased ..... **5.50**  
6 HY 400 MA 100 OHM, Cased ..... **6.95**  
0 HY 450 MA 80 OHM, Cased ..... **6.50**  
7 HY 750 MA 40 OHM, Cased ..... **11.50**

### 115V FILAMENT TRANSFORMERS 60 CY

2.5 VCT 10 A. 10KV Insulation ..... **\$4.50**  
2.5 V 6 Amp. 2.5 V 6 Amp. .... **3.45**  
5 VCT 3A. 2.5 KV Insulation ..... **3.95**  
5 V 20 A. 2.5 KV Insulation ..... **6.85**  
5 V 1.2 A. .... **2.85**  
6.3 V 3 Amps ..... **2.45**  
6.3 V 4 Amps ..... **3.95**  
6.3 V 4 Amps, 6.3 V 4 Amps ..... **2.95**  
6.3 V 3 A. 2 x 2.5 V 3 Amps Herm Seal. .... **3.49**  
6.3 V 8 Amps ..... **2.95**  
10 VCT 10 A. 2.5 KV Insulation ..... **6.00**  
6.3 V 12A, 6.3 V 2 A Herm Seal. .... **4.50**

### 115 V POWER TRANSFORMERS 60 CY

435 VCT 145 MA, 6.3 V 3A, 5V 3A ..... **\$ 2.49**  
700 VCT 90 MA, 6.3V 4A, 5V 3A ..... **4.50**  
700 VCT 150 MA, 6.3V 4A, 5V 3A ..... **2.95**  
800 VCT 200 MA, 6.3V 4A, 5V 3A ..... **4.50**  
800 VCT 300 MA, 6.3V 10.8A, 5V 6A, 5V 2A ..... **9.50**  
750-000-0-000-750 225 MA ..... **2.95**  
3200 VCT 450 MA ..... **4.50**  
115 V, 230 V TAP, PRI. -850 VCT 280 MA -30V 7A-6.3V 3A-5V 3A, Cased ..... **14.50**

### OIL CAPACITORS

7 MF 330 VDC ..... **\$0.95**  
2.5 MF 600 VDC ..... **.41**  
2 MF 600 VDC ..... **.79**  
4 MF 600 VDC ..... **.90**  
4 MF 600 VDC ..... **1.95**  
10 MF 600 VDC ..... **2.49**  
2 MF 1000 VDC ..... **.90**  
5 MF 1000 VDC ..... **1.95**  
10 MF 1KV DC ..... **3.25**  
15 MF 1KV DC ..... **3.95**  
2 MF 1.5 KV DC ..... **1.75**  
4 MF 1.5 KV DC ..... **2.75**  
6 MF 1.5 KV DC ..... **2.95**  
1 MF 2000 VDC ..... **1.79**  
25 MF 2000 VDC ..... **\$1.95**  
2 MF 2000 VDC ..... **2.75**  
4 MF 2000 VDC ..... **4.50**  
8 MF 2000 VDC ..... **6.00**  
5 MF 2500 VDC ..... **1.39**  
25 MF 2500 VDC ..... **2.25**  
5 MF 2500 VDC ..... **1.49**  
3 MF 4000 VDC ..... **6.95**  
1 MF 5000 VDC ..... **5.50**  
8 MF 5000 VDC ..... **10.50**  
4 MF 5000 VDC ..... **11.50**  
2 MF 6000 VDC ..... **12.95**  
1 MF 7500 VDC ..... **1.25**

TERMS: 25% Deposit with order, balance C.O.D. Rated firms open account

**POLY-TECH**  
919 Dawson St., New York 59, N. Y.  
Tel. MURRAY Hill 6-2650

## Naval Communications

(Continued from page 38)

Centers. Over one-half of the installations already are operative. The equipment furnished is the same as that employed in the Naval Communication Service. It is equivalent to the best to be found in either military or commercial establishments. Teletype training is of two types—operational and rate training for communication personnel, technical training for maintenance personnel. Radiomen are responsible for the operation, repair, and operational maintenance of the basic teletype equipment. Electronics technicians are responsible for maintenance and repair of the electronics components.

The technical instruction includes all aspects of teletype communication equipment, both landline and radio. Operational training covers the general field, from the relatively simple reception of teletype broadcasts and "press-to-type" automatics such as are used on v.h.f. and u.h.f. circuits, to the more complex communication-center type of operation which involves automatic tape relay and other advanced techniques.

In addition to the complete units described, each Training Center has two teletype machines, which may be operated within the Center for operational and maintenance training. Many activities have constructed auxiliary equipment which permits the use of these machines on live radio circuits. Radioteletype training circuits are included in the Reserve Communication Networks of several Naval Districts.

### The "CIC"

To provide practical training in one of the most important phases of Naval operations, major Combat Information Center (CIC) installations have been made at selected Naval Reserve Training Centers and Naval Air Stations. Geographical and personnel considerations govern the selection of activities for major installations. Some of these are complete CIC's as found on fighting ships, and like those aboard ship have presentations for the display of radar information, for controlling aircraft, and for assisting in the surface problem. They make possible advanced training of officers and men, working together as a coordinated team. Exercises are conducted in tracking and plotting actual radar targets and in controlling aircraft in flight. When "live" targets are not available, simulated exercises are introduced by means of electronic problem generators. Basic CIC installations are provided at all Naval Reserve Training Centers not designated as advanced CIC training points. All of the reserve CIC's have enough equipment to enable Reservists to practice the fundamental tactical problems which they may later encounter aboard ship. Certain outstanding Electronics Fa-

No GHOSTS in a town with .. **EB\***

**ELINCOR**

EB\* Series Five Element TV Yagi  
Model 707-EB to 713-EB for Chan. 7 to 13. L.P.S. \$7.95  
Model 902-EB to 906-EB for Chan. 2 to 6. L.P. 23.60  
Elincor is a pioneer in the development of Yagi antennas which are superior in strength, quality and dependability.  
All Elincor Yagis now furnished with transformer for matching to 300-ohm line. No stacking bars required.  
Send for literature.

**ELECTRONIC INDICATOR CORP.**  
259 GREEN STREET • BROOKLYN 22, N. Y.

## REK-O-KUT presents a New Continuously Variable-Speed Turntable of Broadcast Quality



Plays at any speed from 25 to 100 R. P. M., without "wow!"  
Speed can be varied while in operation to produce sound effects.

Now for the first time .. a continuously variable turntable of Broadcast Quality at a popular price. Ideal for record collectors, musicians, singers, disc jockeys, broadcast stations, music schools, dance studios, skating rinks, gymnasiums, etc. Plays through amplifier, radio, TV set or phonograph. Operates on 50 or 60 cycles.

**Model CV5-12 (illustrated)**  
Chassis, motor and turntable **\$84.95 net.**  
**Model CV5-12P**, mounted in portable case with 16" dual stylus pickup **\$124.95 net.**

\*\*\*\*\*  
**3-Speed 12" Transcription Turntable**  
Recommended by outstanding music critics. Induction-type motor designed for smooth, quiet, vibration-free operation. 3 speeds, 78, 45 and 33 1/3.  
**Model LP-743** **\$54.95 net.**  
\*\*\*\*\*  
Write for Illustrated Catalog of REK-O-KUT Line of Hi-Fidelity Recording Instruments, Phonographs, Transcription Tables, Accessories.

**REK-O-KUT CO.**  
38-05 QUEENS BLVD., LONG ISLAND 1, N. Y.



cilities are furnished various types of radar equipment, including search radars, to permit technical and operational training.

### ASW

As in the case of CIC, certain Naval Reserve Training Centers have been designated as major Anti-Submarine Warfare (ASW) training locations. These activities have been furnished with the latest type electronic equipment used in undersea warfare, plus suitable training aids. Target simulators also have been provided for both individual and team training. Other Training Centers have been equipped for basic ASW training. Although the equipment is not as complete or elaborate as that furnished to the major ASW training centers, it is sufficient to provide individual training in the fundamentals of sonar.

### Inter-Service Training

Members of Reserve components of the Army, Air Force, Marine Corps, and Coast Guard may be authorized to attend drills with units of the Naval Reserve, under certain conditions. Similarly, members of the Naval Reserve may be authorized to attend drills with units of Reserve components of the Army, Air Force, and Marine Corps. In both cases, inter-service training is confined to personnel on a non-pay status and is authorized only when appropriate training with a Reserve unit of the individual's own service is not reasonably available.

Where individual members of Reserve units of the Army, Air Force, Marine Corps, or Coast Guard are authorized to train with the Naval Reserve, they are integrated into Naval Reserve Training groups appropriate to their ratings or classifications and receive Navy instruction and supervision. In some cases, complete Reserve units of the other services are authorized to use Naval Reserve facilities, furnishing their own instructors and supervisors for classes and drills.

### Emergency Communications

Although the primary purpose of the Naval Reserve Communication System is to provide training, the potentialities of Naval Reserve radio circuits for service in disasters and emergencies have been written into District Reserve Communication Plans. Provision is made for the integration of the Reserve System into the Naval Communication Service as necessary. At the local level, emergency planning by each Naval Reserve activity includes acquainting civic authorities, the Red Cross, radio amateurs, and all interested agencies with the facilities available for emergency communication service.

Not only are Naval Reserve radio stations equipped with portable transmitters and receivers and emergency power, but mobile communication vans are available within each Naval District for dispatch to stricken areas as

May, 1951



# C-D's Champion PUP

—from a long line of winners!

Just introduced—already rated “best in its class”! It's C-D's PUP, the new and advanced metallized capacitor. *Saves space*—half the size of conventional paper tubulars. *Saves trouble calls*—unique self-healing feature means extra long service life.



Write for Bulletin N142, Dept. RN-51  
Cornell-Dubilier Electric Corp.  
South Plainfield, N. J.

## CONSISTENTLY DEPENDABLE CORNELL-DUBILIER CAPACITORS

Plants in South Plainfield, N. J., New Bedford, Worcester and Cambridge, Mass.; Providence, R. I.; Indianapolis, Indiana; Fuquay Springs, North Carolina, and subsidiary, The Radiart Corporation, Cleveland, Ohio.

### Advance with ELECTRONICS CITY

You need firm grasp of fundamentals to keep pace with these complex, fast-growing fields. In thorough 2-year course learn electricity, electronics, physics, mathematics, drafting, etc. Employers want Franklin graduates. Fed. G.I. approved. Day, evening. 43rd year. Write for Catalog

FRANKLIN TECHNICAL INSTITUTE  
46 Berkeley Street Boston 16, Mass.

### PEN-OSCIL-LITE

Extremely convenient test oscillator for all radio servicing; alignment • Small as a pen • Self powered • Range from 700 cycles audio to over 600 megacycles u.h.f. • Output from zero to 125 v. • Low in cost • Used by Signal Corps • Write for information.

GENERAL TEST EQUIPMENT  
38 Argyle Buffalo 22, N. Y.

### No Experience Needed To PRINT YOUR OWN POST CARDS

The GEM STENCIL DUPLICATOR saves money... gets results quickly! Hundreds of uses for every type of business and organization. We ship the GEM complete with all supplies, Guide Board for accurate printing and 60-page Book of Ideas at the special low price of only \$8.50 (a \$15.00 value)

Our  
21st Year

### FREE TRIAL OFFER

Use the GEM FREE at our expense! SEND NO MONEY. Write and complete GEM outfit will be sent you postpaid. After ten days, send us only \$8.50 or return the GEM. You must be satisfied! WRITE TODAY.

BOND EQUIPMENT CO. Dept. 52  
6633 Enright • St. Louis 5 Mo.

# BELIEVE IT OR NOT!

## 630ts TYPE CHASSIS

Mfg. Licensed Under R.C.A. Patents

## 31-TUBE CHASSIS

Complete with Picture Tube

1. Best for Fringe Areas.
2. Improved Keyed A.G.C.
3. Full 4 Megacycle.
4. 16 K.V. Output.
5. A.F.C. Sync. Separator Syncrolok.
6. Latest 1951 Features.
7. Focus Coil. Yoke Removeable Plugs.
8. Standard Tuner.
9. Improved Down to 45 Microvolts.
10. Set Equipped Phono Jack.
11. Set uses 70° Deflection Coil.
12. Complete Chassis with Tubes Aligned. Not a Kit.
13. Large 12" Speaker.
14. All Knobs. Channel Selector.
15. Universal Brackets. Tube on Chassis.
16. Free Plastic Mask with Every Set.
17. Free Schematic with Every Set.
18. Free R.M.A. Guarantee on Chassis-Tube.
19. Free—No Extras—Tax Included.
20. Free Delivery on Paid Orders—6 or More.
21. Dumont Tuner F.M. Radio—\$10 Extra.
22. Cabinets, Console, 16", 17", 20"—\$59.
23. Cabinets, Half Doors, 17", 20"—\$69.
24. Cabinets, Full Doors, 17", 20"—\$79.
25. Cabinets, Furnished Blonde—Mahogany—Same Price.
26. Dealers Mfg. Special—Lots 12 or More.

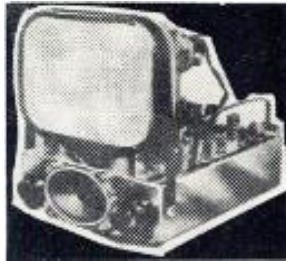

16" ROUND \$179

16" Black Rect. TUBE \$189

17" Black Rect. TUBE \$199

19" TUBE \$219

20" Black Rect. TUBE \$219

24" ROUND \$299

25% WITH ORDER, BALANCE C.O.D. CASH WITH ORDER SAVES C.O.D. FEES.

UPSTATE, 107 Duane, Schenectady, N. Y. Tel. 4-3008

### SCHEMATICS—CONVERSIONS FOR SURPLUS GEAR

NEW LIST! MANY ADDITIONS!

Send stamped, self addressed envelope for List B; Add 25c for chart explaining AN nomenclature.

R. E. BOX 1220  
GOODHEART BEVERLY HILLS, CAL.

### RADIO COURSES

- RADIO OPERATING • CODE
- RADIO SERVICING • ELECTRONICS
- F.M. TELEVISION
- PREPARATION FOR CIVILIAN, MARITIME, ARMY AND NAVY LICENCE REQUIREMENTS.

Write for Catalog T.S.



TRADE & TECH. 229 W. 66 St., N. Y. 23  
SCHOOL Indicott 3-8117



WE HAVE LARGE QUANTITIES OF

## RADIO TUBES

TYPE	OUR PRICE	TYPE	OUR PRICE	TYPE	OUR PRICE	TYPE	OUR PRICE
0Z4A	\$.80	6B8	\$.93	6SH7	\$.80	42	\$.76
1A5GT	.70	6B8G	.93	6SK7	1.04	VR150/30	1.00
1G6GT	.72	6BE6	1.20	6SK7GT	1.04	2E22	2.50
1LN5	.90	6C4	.95	6SS7	1.05	6C21	30.00
1R5	1.06	6C5GT	.51	7Q7	.80	357A	22.50
1S4	.96	6C6	.85	12A6	.48	803	3.00
1T4	.96	6D6	.68	12SH7	.96	805	2.90
5U4G	1.40	6H6	1.04	12SK7	.98	807	1.59
6AB7	1.20	6J5	.86	12SQ7GT	1.22	808	1.70
6AC7	1.65	6J5GT	.51	12SR7	.90	830B	3.00
6AK6	1.65	6K6GT	.91	35Z4GT	.85	866A	1.49
6AL5	1.24	6K7GT	.70	35Z5GT	1.15	9005	1.50
6AQ5	1.40	6SG7	1.04	50L6GT	1.30		

All tubes are brand new standard brands. This offer subject to change without notice and prior sale. Terms: 25% deposit with order, balance C.O.D. \$25.00 minimum order.

MANUFACTURERS: Interested in EXPORT? CONTACT: MICHEL LEVIT

**METROPOLITAN OVERSEAS SUPPLY CORPORATION**  
MANUFACTURERS AND DISTRIBUTORS OF ELECTRONIC PRODUCTS

1133 BROADWAY, NEW YORK 10, N. Y.

CHELSEA 3-1105

needed. Naval Reservists have a long and proud record of emergency communication service to their communities in time of floods, storms, fires, and other disasters when normal communication service is disrupted.

### Amateur Radio

Naval Reservists are encouraged to obtain amateur radio licenses and to participate fully in amateur radio activities. Naval Reserve units with which licensed amateurs are associated are urged to apply for amateur licenses and to engage in amateur operation outside normal Reserve training periods. There are over 500 amateur stations in operation at Naval Reserve Training Centers, Electronics Facilities, and Electronics Stations. They are recognized on the air by special call signs assigned by the Federal Communications Commission. These calls are assigned from the blocks K1NAA through K0NZZ; K1USN, K2USN, etc., through K0USN; and W1USN, W2USN, etc., through W0USN. Distinctive QSL cards, authorized for amateur stations at Naval Reserve activities, will be found on the walls of many ham shacks.

Amateur radio organizations are encouraged to make use of the amateur stations at Naval Reserve activities as meeting places. Numerous ham clubs take advantage of this arrangement. Cooperative effort is then possible between Naval Reserve units and local amateurs in the conduct of classes in radio code and theory for prospective licensees. Close liaison also is maintained between radio amateurs and Reserve units in emergency communications planning and practice. Emergency exercises in which many Reservists participate include particularly the annual Field Days and Simulated Emergency Tests conducted by the American Radio Relay League.

### Individual Hams

Any member of the Naval Reserve, Marine Corps Reserve, or Coast Guard Reserve who is an FCC-licensed radio amateur, and any amateur in the Regular Navy, Marine Corps, or Coast Guard, may, upon request, be authorized to participate in Naval Reserve radio drills from his home station. Naval Reserve call sign and frequency are assigned to the individual amateur for this purpose. His station is designated a "Naval Reserve Radio Station" and an appropriate certificate of authorization is issued. Many amateurs participate in the Electronics Program, both as members of Electronics units and as members of special individual-amateur radio training circuits. Not only does operation on these circuits enable them to obtain additional training in Navy communication procedures, but their stations become part of the Naval Reserve Communication System for emergency communications purposes. More than 1000 radio amateurs have received authorization to participate in Naval Reserve networks.

RADIO & TELEVISION NEWS

In recognition of the skill represented by an amateur radio operator license, individuals who hold such licenses are given special consideration for rapid advancement in the Naval Reserve when they are associated with Volunteer Electronics units. Class A and B amateur licenses may be advanced to Radioman 3rd Class as soon as qualified. No time-in-grade requirement is stipulated. Holders of Class C amateur licenses are rated Seaman Apprentice immediately upon enrolling in a Volunteer Electronics unit, and advancement to Seaman is authorized as soon as qualified. In the case of commercial operators, holders of Commercial Radiotelegraph 1st and 2nd Class licenses may be rated Radioman 2nd Class when qualified, with no time-in-grade requirement. Those who hold Radiotelegraph 3rd Class Operator Permit may similarly be rated Radioman 3rd Class, if associated with a Volunteer Electronics unit.

### An Invitation

The Naval Reserve Electronics Program provides for the individual member an unusual combination of training and self-improvement. As in any field, of course, the return to the individual is proportionate to his interest and effort. The Program has so many diversified aspects that appeal exists for practically all electronics and communications enthusiasts, whatever their sphere of interest. It is worthy of note that a fine spirit of good fellowship exists between officers and enlisted personnel of the Electronics Program. Although appropriate discipline and courtesies prevail as in any military organization, the mutual interest in electronics on the part of officers and men creates an exemplary *esprit de corps*. Officers work shoulder-to-shoulder with enlisted personnel toward a common objective—to be trained and ready for service to the nation when needed. Members of the Naval Reserve performed feats which wrote glorious chapters in the history of World War II. The defense of the nation is dependent upon strong military Reserve forces. The rapid advance of the combined sciences of communications-electronics points up the importance of a strong Electronics Program. The Naval Reserve extends a standing invitation to all persons to participate in the Naval Reserve Electronics Program as regular members, volunteer instructors, advisers, or in any way their talents and experience may best contribute.

Officers-in-charge of Naval Reserve Training Centers and commanding officers of all Naval Reserve units can advise how you can best participate in these interesting and profitable activities. Visit the Naval Reserve activity nearest you and learn first-hand the many opportunities that membership in the Reserve will make available to you. If there is no Reserve activity in your area, further inquiry can be addressed to the commandant of your Naval District.

May, 1951

## SELENIUM RECTIFIERS and ASSOCIATED COMPONENTS

### SINGLE PHASE Full Wave Bridge

Input: 0-26 VAC		Output: 0-20 VDC	
Type No.	Current	Net Price	
D1B1	.750	\$ 3.08	
D1B1	1.5	4.00	
E1B1	3.5	6.48	
F1B1	6.0	8.64	
G1B1	10.0	12.00	
G1B2	20.0	22.40	
G1B3	30.0	31.80	
G1B4	40.0	40.00	
G1B5	50.0	47.00	

Input: 0-52 VAC		Output: 0-40 VDC	
Type No.	Current	Net Price	
C2B1	.750	\$ 5.84	
D2B1	1.5	7.60	
E2B1	3.5	12.38	
F2B1	6.0	16.34	
G2B1	10.0	22.40	
G2B2	20.0	40.00	
G2B3	30.0	54.00	

Input: 0-30 VAC		Output: 0-100 VDC	
Type No.	Current	Net Price	
C5B1	.750	\$12.60	
D5B1	1.5	16.20	
E5B1	3.5	26.46	
F5B1	6.0	33.84	
G5B1	10.0	47.00	

Input: 0-156 VAC		Output: 0-126 VDC	
Type No.	Current	Net Price	
C6B1	.750	\$14.16	
D6B1	1.5	18.24	
E6B1	3.5	30.02	
F6B1	6.0	37.80	
G6B1	10.0	54.00	

### Full Wave Center Tap

Input: 13-0-13 VAC		Output: 0-9 VDC	
Type No.	Current	Net Price	
F1C1	6.0	\$ 4.50	
G1C1	10.0	7.00	
G1C2	20.0	12.00	
G1C3	30.0	18.00	
G1C4	40.0	22.40	
G1C5	50.0	28.00	

All ratings are maximum values for continuous duty to resistive loads. For capacitive, battery charging, or inductive loads, reduce these ratings by 20%.

### Powerstats



Smooth, efficient voltage control 0 to 135V output from 115V AC line.

Type 20 3 amps.....	\$ 12.50
Type 116U (Illustrated) 7.5 Amps	18.00
Type 1126 15 Amps.....	46.00
Type 1156 15 Amps.....	118.00

Also available for 230 volt input. Write for descriptive literature.

16- and 17-inch Rectangular Tubes..... \$3300 ea.  
5U4G tubes available at special prices.

All receiving type tubes available. Send us your requirements.

**BELLE MEAD ELECTRONICS**

BELLE MEAD, N. J. Telephone 812

Immediate Delivery • Critical Radio & TV

# TUBES

25% to 50% OFF LIST

**ADMIRABLE TELEVISION SUPPLY CORP.**

334 Furman St., Bklyn. 2, N. Y. • Triangle 5-7096

## POWER SUPPLIES



GENERAL PURPOSE low voltage DC power supplies, with variable outputs. Rugged—Dependable—Precision Control.

- Features**
- ✓ Long life FULL WAVE SELENIUM RECTIFIERS
  - ✓ Output voltage continuously adjustable from zero to maximum
  - ✓ 3" Voltmeter and Ammeter—2% accuracy
  - ✓ Stepless control
  - ✓ 5-Way Binding Post
  - ✓ Instant Power—no warm-up period
  - ✓ Dimensions: 9x17 1/2x3"
  - ✓ Assembled and Ready to Operate
  - ✓ For 115 VAC 60 cycles

Write for descriptive bulletin GPA

Model	Voltage	Current
GPA810	0-8 VDC	10 Amps.
GPA1210	0-12 VDC	10 Amps.
GPA2810	0-28 VDC	10 Amps.

### FILTER CAPACITORS

CF-1	1000 MFD	15 VDC	\$0.98
CF-2	2000 MFD	15 VDC	1.69
CF-3	1000 MFD	25 VDC	1.69
CF-19	500 MFD	50 VDC	1.95
CF-21	1200 MFD	90 VDC	3.25

Mounting clips for above Capacitors 15c ea.

### FILTER CHOKES

Type No.	Hv.	Amps.	DC Res.	Price
HYX6	.055	.600	2.0	\$ 1.80
HY5A	.028	5.0	2	6.30
HY10A	.014	10.0	.05	11.95
HY20A	.007	20.0	.02	16.75

### TRANSFORMERS

All Primarys 115 VAC 60 Cycles

Type No.	Volts	Amps.	Ship. Wt.	Price
TXF36-2	36	2.0	6 lbs.	5 5.95
TXF36-5	36	5.0	8 lbs.	7.80
TXF36-10	36	10.0	12 lbs.	11.95
TXF36-20	36	20.0	25 lbs.	21.54
XFC18-14	18VCT	14.0	10 lbs.	8.34
XFC18-30	18VCT	30.0	17 lbs.	22.74

All TXF Types are Tapped to deliver 32, 34, 36 Volts. XFC Types are tapped to deliver 16, 17, 18 Volts Center-tapped.

### ATTENTION MANUFACTURERS!

Extend your DO rating to expedite delivery. We will do our very best to fill non-priority orders at the earliest possible date.

Minimum order \$5.00

All prices are FOB our Factory and subject to change without notice. Send M.O. or check. ONLY shipping charges sent COD. Iitated concerns send P.O., Terms Net 10 days.

# Opad-Green COMPANY

71-3 WARREN ST., NEW YORK 7, N. Y. PHONE: BEekman 3-7385-6

Prepare Now!

## RADIO ENGINEERING

**B.S. DEGREE IN 27 MONTHS**

Complete Radio Engineering course incl. Telev., U.H.F., and F.M. BS Degree Courses also in Mech., Civil, Elect., Chem., and Aero Eng.; Bus. Adm., Acct. Extensive campus, modern buildings, well equipped labs. Low cost. Prep courses. Personalized instruction. Heavy demand for graduates. Placement service. Founded in 1884. Prepare now for the civil and military opportunities ahead.

**VETERANS:** You may still obtain training and a college degree at Tri-State College under present G.I. Bill. Last opportunity for new students to enroll is Summer Quarter, June 11, 1951. Hundreds of Tri-State veteran graduates are holding responsible positions with unlimited opportunities for future advancement.

Enter June, Sept., Jan., March. Write for Catalog.

**TRI-STATE COLLEGE**  
1651 COLLEGE AVE. ANGOLA, INDIANA

**You Can't Beat Wholesale Radio for Quality and Price**

## TV ANTENNAS

**UNBEATABLE TV RECEPTION  
BEST FOR THE FRINGE AREAS**

### Snyder Lazy XX TV ANTENNA

Complete with three 3 1/2 ft. masts & adj. mounting base

Extremely hi-gain. Superior construction. Designed to withstand all weather conditions. Easily stacked double conical Lazy XX type. Just unfold, tighten and erect. All TV channels and FM. You also get guy wire rings, and connecting stubs. Completely pre-assembled. Can be used with any type lead-in 72 to 300 ohms. Order model TX-2.



**\$18.99**

### HI-LO FOLDED DIPOLE ANTENNA

Complete with two 3 1/2 ft. mast sections and guy ring. Two folded dipoles (th & lu) with reflectors. TV-21 .....

**\$6.95**

### HI-GAIN DOUBLE V ARRAY

4 hi-tensile 3/8" aluminum alloy elements. Two 3/8" aluminum alloy cross arms. Completely pre-assembled. Less mast. AR55

**\$4.95**

### SNYDER CONICAL ARRAY

Can be stacked for fringe areas. Has 8 interchangeable 3/8" aluminum alloy elements. Use with any type lead-in 72 to 300 ohms. Less mast. XA44 .....

**\$4.95**

### FOLDED HI-LO DIPOLE INLINE ARRAY

All channels. Two folded dipoles with reflector. Universal U clamp for masts up to 1 1/2" di. Less mast. Model AR-29 .....

**\$4.95**

## TV ANTENNA ACCESSORIES

- STEEL EXTENSION POLES. Weather treated.
  - 10 ft. long. 1 1/4" di. .... \$2.19
  - 5 ft. long. 1 1/4" di. Crimped end. .... 1.35
  - 3 1/2 ft. long. 1 1/4" di. Crimped end. .... 1.19
- ANTENNA SWIVEL BASE. Aluminum. Fits 1 1/2" O.D. mast section. .... .45
- GUYWIRE. 3 strand No. 20. Per 50 ft. .... .39
- 24 reels, 50 ft. each, interconnected. .... 6.00
- CHIMNEY MOUNT BRACKETS. Complete with strap. .... 1.59
- 3" 300 OHM STAND OFF INSULATORS. Wood screw-in type (4c ea.) per 100. .... 2.95
- SNAP ON TWIN LEAD INSULATORS. Fits 1 1/4" masts. Each. .... .06
- JFD LIGHTNING ARRESTORS (AT-102). Connects to baseboard. .... 1.35
- JFD LIGHTNING ARRESTOR (AT-105). Connects to baseboard. .... .75
- TIE RODS for double V type antenna. Pr. .... .85
- TIE RODS for conical type antenna. Pr. .... .85
- TIE RODS for inline type antenna. Pr. .... .85
- 10" MAST COUPLINGS for 1 1/4" masts. .... .90
- 8" MAST COUPLINGS for 1 1/4" masts. .... .45
- 48 STACKING ASSEMBLY. 4 rods and a center tie point. For stacking 2 double XX arrays. 1.95
- PEAK ROOF MOUNTS for all type antenna installations. Fits wall, flat roof, any angle peaked roof. For masts 3/4" to 1 1/2". .... 2.69
- HEAVY DUTY MAST BRACKETS WB-2 Adjustable up to 18" from wall. For masts 1" to 1 1/2" di. Pr. .... 3.75
- STANDARD TV FRONT END. Overall Shaft Length 3 15/32" .... **\$29.95**

## HI-FIDELITY, WIDE RANGE REPRODUCTION

### TRIAD HF-10 \$25.00 AMPLIFIER KIT

Freq. Resp. within 1 db. from 20-20,000 cps. Full 10 w. output. High gain -74 db. from crystal microphone or receiver. 96 db. (equalized for magnetic pickup through preamplifier. Kit includes S-31A, R-14A, A-74d, and C-10X transformers, chassis, prints and assembly instructions.

**BELL 2122 HI-FIDELITY AMP. \$50.46**  
10 w. output. Freq. Res. 30-15,000 cps.

**MEISSNER AM-FM RCVR. CHASSIS \$70.95**  
Model 9A-J. Lcs spkr, & output Trans.

**GARRARD 3-SPEED CHANGER \$39.80**  
Model RC-50 Triumph. Less pickup....

**UNIVERSITY 12" PM SPEAKER \$21.00**  
Fr. Resp. 45-10,000. 30 w. output  
Voice coil Imp. 8-12 ohms Model 6200

Write for Free "FYI" Bulletin  
Address Orders to Dept. R-N-5 or Call  
Mulberry 2134

**WHOLESALE RADIO PARTS CO., Inc.**  
311 W. Baltimore St.  
**BALTIMORE 1, MD.**

## TV Close-up (Continued from page 39)

is the director's determination of what he is going to send out over the air that makes the final program either a fulfillment of 125 people's dreams—or disappointment.

There are a number of technical tricks at the director's disposal which he can use to give the show "that certain something."

*He may pan.* This means that the camera follows the action as the performers move.

*He may dissolve.* In this case, the picture of one camera is slowly brought in over the picture of another camera, with the picture on the second camera being withdrawn. This is a technique that is used to achieve the flow from number to number on the Vaughn Monroe Show.

*He may do super-imposition.* In this instance the pictures being recorded by two television cameras are sent out over the air simultaneously. The effect is similar to what you get when you forget to turn the film in your "Brownie" except that, on television, we try to plan it. In this way, it can be made to appear as though a tiny Shaye Cogan is in a frappé glass in front of a life-size Vaughn Monroe, or that rain is pelting down on a set that is actually bone dry.

*And he can cut.* This is purely a matter of switching from the picture on one camera to the picture on another.

There is little else he can do. His tricks are largely limited to those, so that what finally counts is not the tricks at all, but the charm of the performers and the brilliance with which the director can first imagine, then stage, the production he will photograph.

This is why those monitors are such uncompromising critics of the ability of the men who sit in the control rooms and provide us with our television entertainment.



## By Popular Demand OAK RIDGE presents...



FOR THE FIRST TIME!

MODEL 105

### Smallest Precision-Built MULTITESTER

in the Industry!

20,000 OHMS-PER-VOLT

Sensational new miniature test instrument (5 1/2" x 3 3/8" x 3") fully equal to any popular multitester in performance and operating characteristics—yet less than HALF THE SIZE!

- DC and AC Volts: 0-2.5-10-50-250-1000-3000
- Output: 0-2.5-10-50-250-1000
- DC Milliamperes: 10-100-500
- DC Microamps: 100
- Decibels: -12 to +55 in 5 ranges
- Ohms: 0-2000, 0-200,000, 0-20 Meg.

Hi-Volt probe to 25,000 volts available. Ideal for servicing ON-THE-SPOT! A real time and money saver—and moderately priced! Write today for information.

## OAK RIDGE PRODUCTS

37-01-N Vernon Blvd.,  
Long Island City 1, N. Y.

Mfg. Div. of Video Television, Inc.

## Be Safe! Be Sure!

with a FULL-SIZED  
VEE-D-X ARRESTER



COSTS NO MORE THAN A MIDGET

2 WIRE | 4 WIRE

RW-200 | RW-204

\$125 LIST | \$150 LIST



2-WIRE RW-300 \$2.00 LIST

For extra heavy duty. An air gap plus resistors provide double protection.

THE LaPOINTE-PLASCOMOLD CORP.  
Windsor Locks, Conn.

## Compact Ham Rig

(Continued from page 59)

is exactly 12 inches long. The connection to the transmitter is made with a good grade of weather-insulated lead-in such as "twin-lead." Use the 75 ohm impedance line.

Slit the twin-lead between the two leads for a length of about 13 inches. Bare the ends of the leads and solder them securely to the ends of the antenna doublet where the splice has been made. Fan the twin-lead leader for 12 inches.

Connect the free ends of the twin-lead lead-in to the *Eby* binding posts at the rear of the transmitter chassis. Ordinary twisted-pair lead-in, such as is used with short-wave receiver doublets, can be used in the same manner as the twin-lead. If it is used, some losses may be experienced at the high end of 40 meters and it will soon decay with the ravages of weather. The rig will work out well on 160, 80, and 40 meters.

Connect a meter with a 75 or 100 milliamperere full scale reading to a phone plug and insert it into the "Key" jack. With the proper crystal, the coil, and the 6V6GT tube in their sockets, plug the power cord into the wall outlet. In about 10 seconds, the tube will have heated and the meter will give a reading. If the meter needle has moved to the left instead of to the right, simply reverse its connections to the phone plug. The meter will read correctly now. The tuning light will glow and assist in tuning up.

Rotate the tuning knob and you will find a point where the meter needle dips. Simultaneously, the tuning indicator lamp will go dim. The points of maximum meter needle dip and minimum lamp brilliance indicates resonance, the point of tuning where good transfer of transmitter power to the antenna takes place. The meter should read between 40 and 50 milliamperes. Replace the meter with your key and you can go on the air.

### Antenna For Two Bands

There is another simple antenna that works quite well if your shack is

Fig. 4. Details of the half-wave doublet antenna which is suitable for single-band operation. The formula for determining the correct antenna length is included in the text. The antenna can be used on 160, 80, or 40 meters by substituting the correct crystal frequency in the given formula.

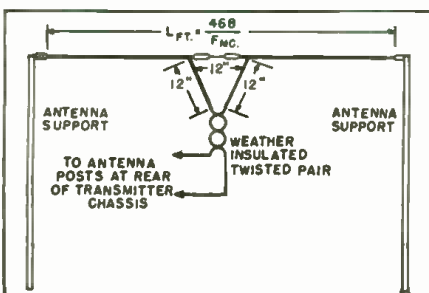

# ARROW "The Home of Values!"

## COMMAND (SCR 274 N) EQUIPMENT

	Used	New
BC-455.....	\$ 7.95	\$ 9.95
BC-457.....	4.95	—
BC-458.....	4.95	—
BC-696.....	14.95	24.95
BC-450—3 Receiver Remote Control	.89	1.95
BC-442.....	—	2.95
3 Receiver Rack.....	1.95	—
2 Transmitter Rack.....	1.50	—

BC 709 Battery operated lightweight interphone amplifier. Complete with tube and shock mount, but less battery. New.....\$3.95 ea.

### FLAP PITCH MOTOR

24 VDC will operate on AC—3300 or 11,000 R.P.M. Complete with gear box and limit switches.....each \$2.95

AS-138/ARN—10 inch streamline loop as used with direction finding receivers. Fixed position, it is ideal for planes, boats, automobiles.

**\$1.95**

## RT7/APN1 TRANSCEIVER UNIT—

Used as an altimeter, it may be converted for signaling control circuits, etc. Complete with 14 tubes and dynamotor they are in good used condition at the amazingly low price of.....**\$6.95**



## MN 26Y COMPASS RECEIVER

twelve stage superhet covering frequencies of 150 to 325 KC; 325 to 695 KC; and 3400 to 7000 KC in three bands. These units are brand new but with Dynamotor, Band switch motor and tubes removed. Schematic Furnished. While they last...\$4.95

## CABINET CH-118

Olive drab in color, this cabinet has a full length interlock access door on the rear. The front takes the standard 19" panels with 60 inches of height and 20 inches deep. It is shock mounted on a heavy steel platform and has a two-inch protrusion fully covering one side to accommodate wave trap and wiring. Louvered vents allow air circulation top and bottom. \$34.50 each F.O.B. Chicago.

### SURPRISE PACKAGE

20 lbs. Ass't radio parts. A \$25.00 value for only **\$1.95**

### SCR 625 Famous Army Mine Detector

Complete kit, brand new in original suitcase style carrying case. Less Batteries.....\$79.50

### RA 52—Rectifier

A Transat controlled rectifier to produce high voltage DC from a 110 VAC 60 cycle source. Up to 11,500 volts DC at 50 watts. Metered high voltage (0-15 KV) and current (0-20MA).

**\$74.50**

TS-10—Sound powered phones — Brand New \$10.00 each. 2 for \$17.95

### CONDENSER SPECIAL

Typical Values:  
1 mfd..... 400 VDC 1 mfd..... 1200 VDC  
1 mfd..... 800 VDC 2 mfd..... 400 VDC  
1 mfd..... 500 VDC

Metal cased with mounting brackets. Ten assorted for only **\$1.95**

### TEST EQUIPMENT

No. M-652 Jackson Audio Oscillator.....used \$29.50  
No. 155 A RCA Oscilloscope.....used 75.00  
No. M-840 Triumph Oscilloscope.....used 39.95

### MONTHLY SPECIAL

BC-455; 6—9 mc Command Receiver, complete with tubes in good condition.....\$5.95 ea.

### TUBE SPECIALS!

1625.....\$0.39 805.....\$3.29 832A.....\$7.95  
1626.....\$0.39 807.....\$1.89 837.....\$1.19  
211.....\$0.59 813.....\$8.95 860.....\$4.95

### CATHODE RAY TUBES

3FP7.....\$1.95 5EP1.....\$3.95 5GP1.....\$3.95  
3GP1.....\$1.95 5EP4.....\$3.95  
4AP10.....\$1.95 5FP7.....\$1.95

## COMPASS RECEIVER MN-26C

Remote control commercial type navigational receiver. Indicates direction of any desired transmitting station. 3 bands—frequency range: 150 Kc to 1500 Kc; has 12—6-V. type tubes.

Brand New.....\$39.95

Accessories for Above:

Loop MN-20.....	\$ 9.95
MN-28 Control Box.....	10.00
MN-52 Loop Control Unit.....	4.45
Loop Transmission Cable—168" long.....	9.95
MC-124 Flexible Shaft.....	2.45
IN-4D Left-right Indicator.....	9.95
Set of 3 plugs.....	4.60

## MISCELLANEOUS SPECIALS!

RA 10 DA Receiver.....\$17.50 \$24.95  
RT7/APN1 Transceiver.....6.95 9.95  
BC 347 Interphone Amplifier.....2.95 2.95  
BC 442 Less Condenser.....1.49 1.95  
APS 13 UHF Antenna, Pair......98  
FL 8 Filter.....2.95  
I-97 Bias Meter.....3.95 4.95  
RL 42 Antenna Gearbox Motor and Reel.....4.95 7.50  
AN ARC-5 VHF Transmitter (T-23/ARC.5).....29.95

### One Tube Interphone Amplifier—Small compact aluminum case fully enclosed. 2 1/4" x 3 3/4" x 5 3/4" Less Tube.....New 79c

40 Amps Circuit Breaker.....New 59c

220 M.A. Circuit Breaker.....New 59c

Collins VFO Dial—S calibrated ham bands from 3.2 Mc to 32 Mc; complete with pointer, gears, logging dial and flywheel. Scale 6" on 8" plate.....New each 95c

C-18—Antenna coil assembly slug tuned used in BC 603 receiver. Frequency range 20-27.9 Mc.—fully shielded.....New. 10 for \$1.95

I 82 F—Five Inch 360 degree compass indicator and Selsyn receiver.....New \$4.95

A-81-2 Transmitter Selsyn for I82 indicator.....\$2.45 (Both I82 F & Trans. Selsyn for \$7.00)

RC 100—Complete or components parts available—Price upon request.

### SCR 508

BC 603 Receiver.....\$24.95

BC 604 Transmitter.....19.95

BC 605 Amplifier.....4.95

BC 606 Control Box......95

FT 237 Mounting.....9.95

MP 48 Mast Base.....2.95

MS Mast Sections.....\$0.49

Set of 80 Crystals.....19.95

DM 34 12 Volt Dynamotor(Rx).....9.95

DM 35 12 Volt Dynamotor(Tx).....14.95

TM 11 600 Manual.....2.50

FE 97 or PE 117 or PE 120 Power Supply for BC-620 and BC-659.

Used less tubes, vib. & con.....\$2.95

Used, complete.....6.95

Shipments FOB warehouse. 20% Deposit on orders. Minimum order \$5.00. Illinois residents, add regular sales tax to remittance.

**ARROW SALES, Inc.** Dept. N, 1712-14 S. Michigan Ave., Chicago 16, Ill. PHONE: HARRISON 7-9374

## The NEW MODEL 25 high output crystal oscillator

FOR SPOT FREQUENCY RECEIVER ALIGNMENT both in the factory and service shop



### FEATURES

High output — .5 volts Available for 4.5, 20 to Terminated 75 ohm output probe 30, and 40 to 50 mc. Uses inexpensive harmonic type crystals Completely self-contained crystals Compact — 3" x 4" x 5"

PRICE Net. Complete with terminated output cable \$26.75

ACCESSORIES REQUIRED Crystals for specified frequencies:

4.5 megacycles.....	\$6.00
20 to 30 mc. range.....	7.25
40 to 50 mc. range.....	8.25

**CREST TELEVISION LABORATORIES, Inc.**  
2117 MOTT AVENUE • FAR ROCKAWAY, N. Y.



tune with the transmitter. The center link on the antenna coil is adjustable, simply by bending it in or out of parallel with the side windings. This is useful in adjusting the quality of your signal consistent with good power output. If the coupling is too tight, the oscillator may be erratic or even refuse to operate, or your signal may sound "chirpy." Then again, too loose coupling will not allow full power to be transferred from the transmitter to the antenna.

If the dial lamp in the antenna lead does not give sufficient indication to be observed, substitute a 2 volt 60 milli-ampere lamp. In operation, the knife switch should be closed after the tuning procedure has been completed and the meter has been replaced with a key. The rig is so small that it can be placed on the night table of the guy who says to his wife, "Just one more QSO before I go to bed, dear." —30—

### TUBE SUBSTITUTE

By NORRIS HEKIMIAN

**N**OW THAT it is becoming more and more difficult to find replacement tubes for television sets, one substitute has evolved which has proven fairly useful.

It is possible to substitute selenium rectifiers for horizontal deflection damper tubes in television receivers. By using a 150 ma. selenium rectifier rated at 350 volts peak inverse voltage in place of the damper tube, one of my substitution problems has been solved.

All that is necessary is to either wire the selenium rectifier into an old tube base or simply solder two one-inch lengths of No. 12 wire to the unit and insert it in the damper tube socket as shown in the diagram of Fig. 1.

While there is some reduction in deflection efficiency due to the lower back resistance of the selenium rectifier as compared to the vacuum tube rectifier, the loss is slight. The increased ruggedness and cooler operation, together with the surge current capabilities, compensate for the loss and, after all, the set does work! —30—

Fig. 1. Method for substituting a selenium rectifier for horizontal damper tube.

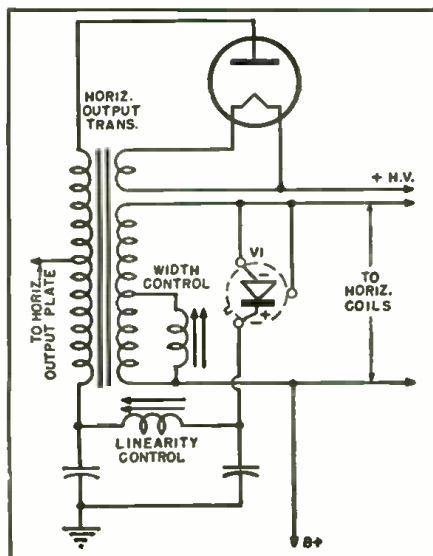

## 1951 Edition

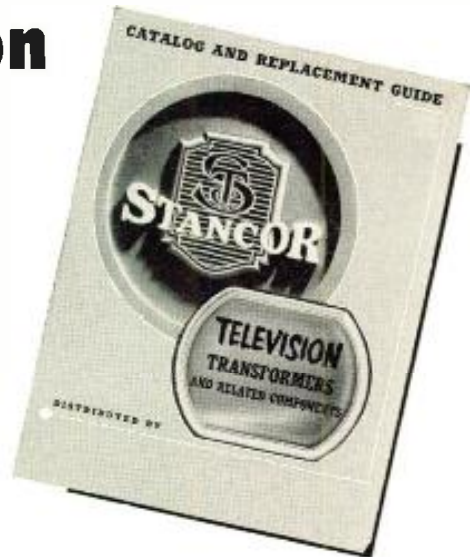

*Ready!  
NOW!*

# STANCOR'S

*New*

## TV TRANSFORMER CATALOG AND REPLACEMENT GUIDE

### Lists:

- Over 900 TV receiver models and chassis made by 71 manufacturers.
- Complete specifications, dimensions and prices of 75 STANCOR transformers and related components for replacement and conversion.

**TAKE THE GUESSWORK OUT OF YOUR TV SERVICING! GET YOUR FREE COPY NOW AT YOUR STANCOR DISTRIBUTOR**



**STANDARD TRANSFORMER CORPORATION**

3584 ELSTON AVENUE, CHICAGO 18, ILLINOIS

## 300 ohm TV wire . . . NOW is the time

to stock up! By next Fall, the demand will be terrific, and the dwindling supply will be almost priceless due to increasing controls on materials used in manufacturing T.V. wire, and curtailed production due to war work. Send your orders in now! Immediate shipment!

### ALL POLYETHYLENE INSULATION

80 Mil Web	20 Gauge	\$25.00 per/M ft. Metal Spls.
55-60 Mil Web	20 Gauge	23.50 per/M ft. Metal Spls.
55-60 Mil Web	22 Gauge	22.50 per/M ft. Metal Spls.
35-40 Mil Web	22 Gauge	17.50 per/M ft. Cardboard Spls.

TERMS: Check with order, or we will ship C.O.D.

**Jersey Specialty Company, Inc.**

LITTLE FALLS

NEW JERSEY

Phones: Little Falls 4-0784, 1404, 1405



## "A" BATTERY ELIMINATORS

Makes it easy to DEMONSTRATE AND TEST D.C. APPARATUS FROM A.C. LINES



### for DEMONSTRATING AND TESTING AUTO RADIOS

New Models . . . Designed for testing D. C. Electrical Apparatus on Regular A. C. Lines. Equipped with Full-Wave Dry Disc Type Rectifier, Assuring Noise-less, Interference-Free Operation and Extreme Long Life and Reliability.

NEW MODELS NEW DESIGNS  
NEW LITERATURE

"A" Battery Eliminator, DC-AC Inverter  
Auto Radio Viators

See your jobber or write factory



AMERICAN TELEVISION & RADIO CO.  
Quality Products Since 1931  
SAINT PAUL 1, MINNESOTA-U. S. A.

## Resistance Welding

(Continued from page 52)

carrying ability. The tube must be capable of carrying the full primary current of the welding transformer. Vacuum tubes are immediately disqualified since their current ratings are measured in milliamperes. The gas-filled triode (thyatron) is next in

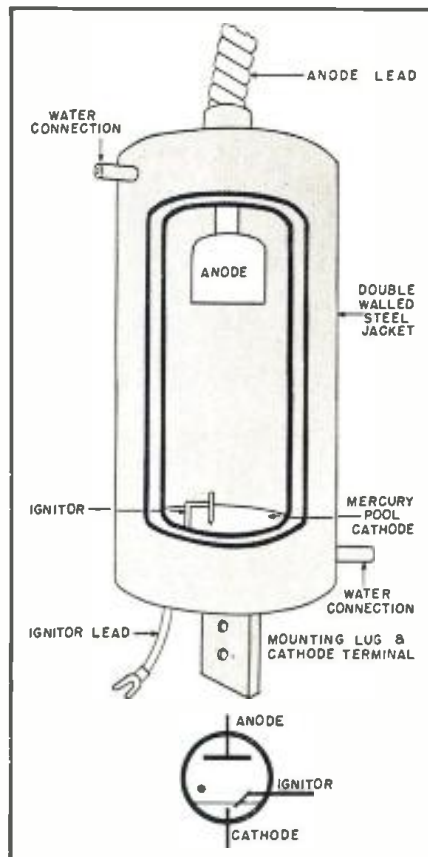

Fig. 2. The ignitron. The pool of mercury is an almost indestructible cathode and the tube can thus carry thousands of amperes.

the sequence of considerations, but its current rating rarely exceeds 10 or 15 amperes, insufficient for this application. The current carrying capacity of the thyatron is limited by the fact

that, in operation, its cathode is bombarded by positive ions of gas. The current is thus limited by the threat of cathode disintegration. If a pool of liquid mercury is used as a cathode, it will not be damaged by ionic bombardment and the tube will safely carry hundreds, even thousands, of amperes. The ignitron is a liquid cathode tube of this type.

Fig. 2 illustrates the construction of the ignitron. The pool of mercury in the bottom of the tube serves as the cathode. The anode is made of graphite and is located at the other end of the tube. Graphite is used because it is a good radiator of heat and also because it does not emit electrons when operated within its ratings. This feature prevents back-conduction through the tube. The envelope of the tube consists of a double-walled, steel jacket. Water is circulated through the space between these walls for cooling.

The ignitron is a cold-cathode tube. A starting electrode, the ignitor, is therefore used to initiate current flow. The ignitor is pointed piece of silicon carbide or similar hard substance and is in contact with the mercury cathode. When a voltage is applied between the ignitor and the cathode, a spark occurs at the junction of these two elements. This spark vaporizes and ionizes a quantity of mercury, after which current flows to the anode.

### Back-to-Back Circuit

Fig. 3 shows a representative diagram of a welding circuit. The two ignitrons are connected "back-to-back" so that one will conduct on the positive alternations and the other on the negative. In this way, alternating current flows in the circuit even though two half-wave tubes are used. Rectification is neither necessary nor desirable in this application. The ignitrons are used as a heavy duty switch to turn the welding current on and off at the desired rate. Two thyratrons are used in the circuit, one in series with the ignitor of each ignitron. With this arrangement, each ignitron will fire when its associated thyatron is fired. Since firing of the thyatron can be delayed through any portion of the posi-

Fig. 3. The back-to-back circuit and the typical "on-off" sequence.

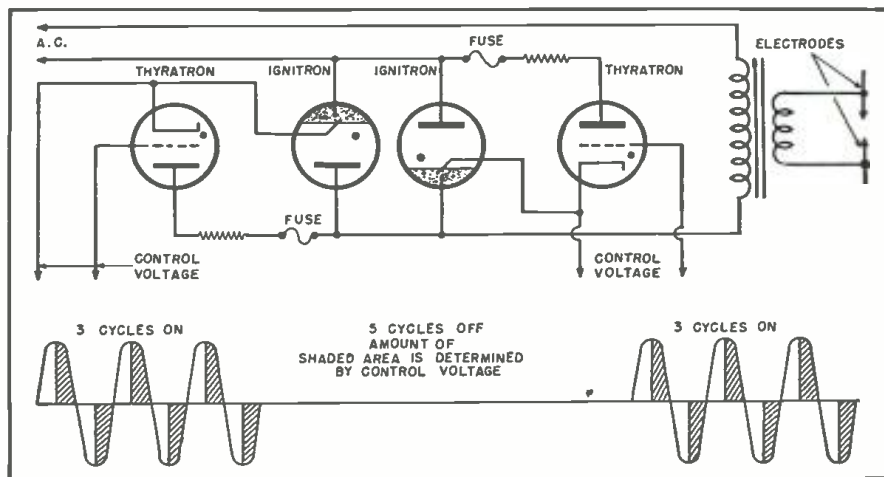



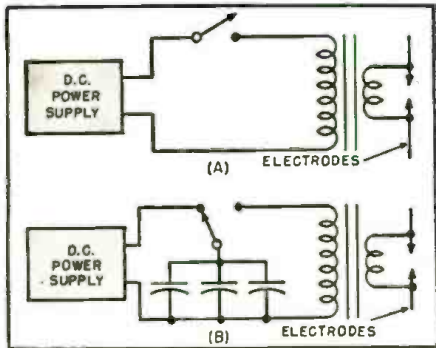

Fig. 4. (A) Magnetic energy storage welding. When switch is closed, current from d.c. supply establishes magnetic field in transformer. When switch is opened, magnetic field collapses and induces current in secondary. (B) Condenser type of energy storage welding. When switch is thrown to left, condensers charge from d.c. supply. When switch is thrown to right, they discharge through transformer and weld is made.

tive alternation, the average current carried by the ignitrons can be easily controlled. The sequence of current flow is illustrated in Fig. 3. The circuit is alternately turned on and off for three cycles of heat time and five cycles of cool time. The shaded areas indicate the times during which the ignitrons are conductive. This amount of shaded area is controlled by the voltage applied to the grids of the thyratrons. Either magnitude or phase control may be used. The shaded area, and therefore the average current and the heat developed in the work, can be easily controlled and adjusted to suit the requirements of individual jobs.

### Energy Storage Welding

As suggested by its name, energy storage welding involves a period of time during which energy is stored, followed by an interval in which the stored energy is released to produce the weld. The energy may be stored either in a magnetic field or in a bank of condensers. Fig. 4A illustrates the magnetic energy storage system. With the switch closed, the d.c. power supply passes a current through the primary of the welding transformer. A high inductance primary is used so that an intense magnetic field will be established. To produce the weld, the switch is opened. With the opening of the switch, the magnetic field will collapse. This collapsing field cuts across the secondary and induces the voltage and current to produce the weld.

Fig. 4B illustrates the condenser type of energy storage welding. The switch is first thrown to the left to allow the condensers to charge from the d.c. supply. When the switch is thrown to the right, the condensers discharge through the transformer, producing the weld.

The technique of resistance welding has contributed immeasurably to the improvement of many of the metal products which play a vital role in our everyday lives—products that we buy directly and products which serve to improve our standard of living.

SEE LEO FIRST FOR . . . .

# hallicrafters!

I can SAVE you money... Liberal Trade-ins



A TAILOR-MADE SET FOR THE BEGINNING AMATEUR OR NOVICE...

### New SR-75 TRANSCEIVER



\$79.95

Receives on 540 Kc through 32 Mc — Transmits on 10, 11, 20, 40, or 80 meter bands. 5 tubes plus regulator. Housed in grey steel cabinet. Shipped with coils, less crystals. Low down payment.

### New S-76 RECEIVER



\$169.50

R-46 Speaker \$19.95

Extra selectivity with double superhetrodyne circuit. One RF, two conversion and 3 IF stages. Range 550-1550 Kc, 1.7-34 Mc in four bands. 8 tubes plus voltage regulator and rectifier. Complete with tubes, less speaker.

HALLICRAFTERS RECEIVERS AVAILABLE FOR IMMEDIATE SHIPMENT

S-38B ..... \$49.50  
S-40B ..... \$99.95

S-72 Portable ..... \$109.95  
SX-62 ..... \$289.50

WRITE FOR DETAILED SPECIFICATION EQUIPMENT SHEETS



**RADIO REFERENCE MAP**  
CU ON 10-20 & 75 MEYERS  
Just right for your control room walls. Approximately 28" x 36". Contains time zones, amateur zones, monitoring stations. Mail coupon today and... **25c**

**FREE**

Send for the 1951 complete WRL Catalog containing everything new in radio and television. Deal with the "World's Most Personalized Radio Supply House."



Trade for a new Hallicrafter Receiver. I'll allow you more for your present equipment. WRL buys more equipment... WRL sells more equipment. Our large volume of sales means faster turnover, greater savings for you! We finance our own paper—no red tape! **LOW DOWN PAYMENTS NAME YOUR TERMS PERSONALIZED SERVICE**

PHONE 7795

WRITE—WIRE



COUNCIL BLUFFS, IOWA

WORLD RADIO LABORATORIES  
744 West Broadway  
Council Bluffs, Iowa

R-5

Please send me:

- Radio Map  SR-75 Info  
 New Catalog  S-76 Info  
 List of Guaranteed Used Equipment

Name .....

Address .....

City..... State.....

### DO YOU WANT TO STOP TOBACCO?



Banish the craving for tobacco as thousands have with Tobacco Redeemer. Write for free booklet telling of injurious effect of tobacco and of a treatment which has relieved many men.

In Business Since 1909  
300,000 Satisfied Customers  
**FREE BOOK**  
THE NEWELL COMPANY  
462 Clayton Sta., St. Louis 5, Mo.



### RADIO ENGINEERING TELEVISION ELECTRONICS

Thorough training in all phases of radio and electronics, open to high school and junior college graduates. Old established school specializing in Radio training exclusively. Modern laboratories and courses. Enrollments limited. Approved veteran training.

VALPARAISO TECHNICAL INSTITUTE  
Dept. RD Valparaiso, Ind.

### CONDENSERS OUR SPECIALTY OIL FILLED TYPES

All Values and Voltage Ratings

We Invite Your Inquiries

TECHNICAL RADIO PARTS CO.  
557 McDonald Ave., Brooklyn 18, N. Y.

## PORTABLE POWER

Look at These Combination Kits!

- 2 volt, 30 amp hour wet cell BB-54, Light-weight transparent plastic, Non-spill, Fibrite-sealed, 3-ball hydrometer, 4" x 3" x 5 1/2" high overall. Shipped dry, with filling and charging instructions.
- 2 volt synchronous Vibrator. No tube needed.
- 2 volt charger, 115 v, 50/60 cy in. High quality unit. Uses step-down transformer and dry-die rectifier, with pilot lamp in output to indicate and regulate charging rate. With instructions.
- Eyedropper-type battery filler.

ALL 4 ITEMS, ALL BRAND NEW, ONLY... \$3.95

OR  
3 BB-54 and new box CH-291 made for them. \$4.95  
Set-up gives you 8 volts, for ONLY... \$4.95  
(The boxes interlock and snap-clasp together and are masterpieces of compact, light-weight craftsmanship! Use 2 set-ups for 12 v., 4 for 24 v.)

## FOR MARINE RADIOMEN G.L. "MARINER" TRANSMITTER

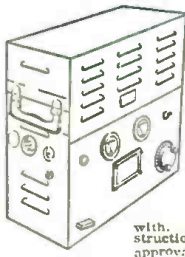

180 w input, 120 w to antenna, 90% modulated, 4 channel xtal cont. 12 or 24 v input with dynamotor, connecting cord, xtals, tubes, mike, all aligned and ready to operate. (Specify volt. and freq. when ordering.) Contains break-in relay for receiver in addition to ant. switching relay. Dimensions: 5 1/2" deep, 7 3/4" wide, 1 1/2" high. Tubes included: 10Y speech amp., two 211 mod., 12J5 osc., 1625 PA., two 614 paraffin P.A. add over \$150 worth of skilled engineering and parts equipment. FCC license for U.S. over \$1200 to start with. How can you lose? With instructions, approval guaranteed. \$275.00 (Includes external harmonic filter)

## G.L. "MARINER" RECEIVER

Long wave broadcast, marine and short wave reception. A beautiful conversion of finest Navy surplus. All controls of broadcast band, tuning, BFO ON-OFF and AVC-MVC on entirely new front panel. Coaxial type antenna and speaker furnished. Tagged wires out of rear to battery to power a DU-1 loop, and to kill B+ with xtal break-in relay, 12 or 21 v DC. Only 15 1/2" long, 8" wide, 6 3/4" high, and self-contained, no plugs needed. With G tubes, no neon voltage limiters, and dynamotor. Requires an external speaker. Alignment instructions and schematic furnished. \$69.50



MARINE FREQ. COMMAND RECEIVER NAVY ARA (SCR-274-N) 1.5 to 3 MC spread over entire dial. Very hot! Modified, entirely self contained. (Less speaker.) New \$275.00. 24V. \$27.50  
NAVY WATERPROOF WALKHEAD SPEAKER with universal matching transformer, cord and phone plug. \$9.95

3-SECOND MANUAL DIRECTION FINDER  
DU-1. 12 or 24 v. Goes ahead of the G.L. "Mariner," ARA, or any other receiver. We convert it to the Marine band. Still retains a pair of broadcast band, and all the light-house and beacon band. 2-tube phasing circuit, no 180° ambiguity. Gives true bearing in 3 seconds! Schematic and complete instructions. BRAND NEW, specify voltage. \$32.50

20-WATT TRANSMITTER  
BC-223 TRANSMITTER, 15 to 25 w output, 4 chan xtal control. WE CHECK THEM OUT! With tubes, 12 v dynamotor, PE-55, connecting cable, marine frets, xtals, mike and schematic. \$89.50  
Add \$12.95 for Harmonic Filter

New FCC rules require harmonic suppressor for Marine transmitters. Don't get pink tickets. Suppressor filter, complete with Ant. Current meter. \$12.95

## COMMAND EQUIPMENT

With free dope sheets and schematics.  
**RECEIVERS**  
ARC-5 or ARA, 3-6 mc. good used... \$5.95  
BC-455, 6-9 mc. New \$12.95. GOOD USED... 7.95  
**COMMAND TRANSMITTERS**  
T-19/ARC-5, 3-4 mc. repacks, like new... \$10.95  
Excellent used... 8.95  
BC-457, 4-5.3 mc. excellent used... 4.95  
BC-458, 5-5.7 mc. excellent used... 5.95  
BC-459, 7-9.1 mc. excellent used... 9.95  
T-22/ARC-5, 7-9.1 mc. repacks, like new... 9.95  
T-23/ARC-5, 100-150 mc. New, with tubes... \$4.50  
MOD-7/ARC-5, Push-pull mod. excellent... 9.95  
MOD BC-456, Brand New \$5.95. Excellent used 2.49  
274N PLUG, 7 prong male plug to fit back of command recvs and xmits. This is the same plug used in the racks. NEW, each 24c; five for... \$1.00  
Local Control Adaptor parts for 274N or ARC-5 recvr. Exact pot, switch, knobs, etched plate and instruction data, ready to mount... \$1.29  
Spline tuning knob... 79c

## 4 USES—4 DOLLARS

The most versatile dynamotor in surplus! The best dynamotor for conversion to Gv. Multiple windings! After conversion you get choice of 100 or 350 v at 50 MA or 250 v at 100 MA. No brushes to shift ground, no mechanical work. Or use it as a 2:1 or 1:2 step-up or step-down transformer for DC voltage! Changes 0 to 12, or 12 to 24, or vice versa, up to 3 A. Or use it as a GENERATOR. Turn with motor, get 12 v DC at 13.6 A or 24 v DC at 6.3 A, plus high voltage. Includes easily removable self-contained 500:1 sealed-in-oil gear reduction unit. Complete dope sheet furnished. BRAND NEW... \$4.00  
3-DIGIT resettable Vee-Root counter with 50° level-gear drive, pilot lamp assembly, wafers switch, case. NEW... 79c  
METALLIC MINE DETECTOR SCR 625 with BA-38 battery. For non-ferrous or ferrous metals. Also operates under water. Brand new, export packed. \$69.50

## DYNAMOTORS AND INVERTERS

(Quantity buyers, write for discount.)  
FOR AN ARC-1, DY-10/ARC-4X (27 or 13.7 v). Output 300 v, 1.5 ma cont., or 510 v, 1.53 ma. lit. Guaranteed condition... \$12.50  
FOR BC-375, PE-73, 28 v in. output 1000 v, 350 ma. Brand new... \$5.95  
FOR A.D.F., 750 VA Inverter SIG-149.F. Input 24 v, outputs 115 v, 500 VA, 400 cy plus 26 v, 25.4 v, 400 cy. Excellent used... \$7.95  
FOR RADAR, PE-218 Inverter, 25-28.5 v in. Output 115 v, 13 amp (1.5 KV.A), 400 cy. NEW... \$17.50  
Out of original packaging... \$12.50

WANTED!  
Your Spare Surplus Equipment and Tubes, Dynamotors, Recvrs., Xmits., Test Equipment. Send List, stating condition and rock bottom price.

## G.L. ELECTRONICS

905 S. Vermont Ave., Los Angeles 6, Calif.  
All Prices F.O.B. Los Angeles.  
Calif. Buyers Add Sales Tax.

# NEW TV PRODUCTS

## DISC CONDENSERS

Cornell-Dubilier Electric Corporation of South Plainfield, New Jersey has recently announced a new series of miniature ceramic disc condensers for bypass and coupling in TV, FM, u.h.f. and v.h.f. in compact, miniaturized equipment.

Known as the "Tiny Mike" series, the new units are available in five basic types. The Type 2 TM is 1/4" in diameter and is available in single capacity units from 500 to 1000 µfd. at 500 v. Information on these condensers is contained in the company's Bulletin No. 2-610. The Type 6 TM is 19/32 inch in diameter as single capacity units from 50 to 5000 µfd. at 500 v. Bulletin No. 2-611 covers these units.

The Type 8 TM is 3/4" in diameter and has a capacity rating of 10,000 µfd. (8TM5S1C) at 500 v. Bulletin No. 2-612 carries data on these units. The Type 6 TM dual capacity units (from 2 x 100 to 2 x 2500 µfd.) measure 19/32" in diameter. The Type 8 TM dual capacity unit (from 2 x 3000 to 2 x 10,000 µfd.) measures 3/4" in diameter. The last two types are described in Bulletin No. 2-613.

## ADVANCED TV KIT

Tech-Master Products Company, 443 Broadway, New York 13, New York has recently introduced a new television kit which incorporates several unique features.

The basic Type 630 circuit has been improved and the new kit offers a

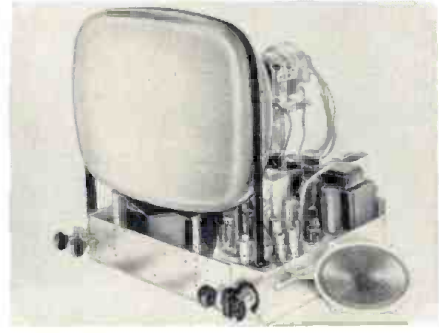

quick action keyed a.g.c. circuit, a "hi-sweep" voltage multiplier system, an advanced twelve-channel turret tuner, full 4 mc. bandwidth, and excellent sensitivity.

The kit comes complete with carefully planned schematic and pictorial diagrams.

The new kit is available in two models. The deluxe kit, Model 630D19, has the principal components mounted in place while the standard kit, Model 630S19, comes unassembled. Both kits include all components, picture tube mounting brackets, speaker, and all tubes. The picture tube, wire, and

# STAY ON THE AIR WHEN POWER FAILS...with an ONAN Electric Plant



AUTOMATIC START & STOP

Model 10EL, 10KW A.C.

When storms, floods, or fires interrupt electricity and force you off the air, you lose listeners and income. Guard against loss, assure vital public service during emergencies by installing an Onan Electric Plant. Onan Standby Electric plants serve many network and private stations. Automatic models to 35,000 watts.

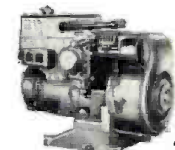

PORTABLE ELECTRIC PLANTS FOR MOBILE RADIO USES  
Supply A.C. power for broadcasting at scene of events. Can be carried by hand or in trunk of car. Weigh as little as 80 pounds. A.C. models 350 to 35,000 watts.

Write for FREE Folder



D. W. ONAN & SONS INC.  
4813 Royalston Avenue  
Minneapolis 5, Minnesota

## "Little Giant" TWIN LEAD LIGHTNING ARRESTER

Protects TV Sets Against Lightning and Static Charges

ONLY JFD Lightning Arresters offer you these exclusive patented features...

1. Patented strain-relief Retaining Lip which prevents pulling or straining against contact points.
2. You actually see positive contact made with lead in wire.
3. Lead-in contact remains fully visible at all times.
4. No wire stripping. No Arrester Cover to Hide Poor Contacts!

At Your Jobber or Write Direct

JFD MANUFACTURING CO., Inc.  
6105-E 16th Avenue, Brooklyn 4, N. Y.  
FIRST in Television Antennas and Accessories

Underwriters Laboratories Approved  
No. AT105  
\$125 List  
For Regular Twin Lead

solder are not furnished. The chassis measures 21 3/4" wide by 15 3/4" deep.

**CROWN ROTATOR**

Crown Controls Co., Inc. of 124 So. Washington Street, New Bremen, Ohio has announced the availability of a new antenna rotator drive motor



which features 5/8" steel drive shafts and 3" final shaft steel gears for greater strength and more turning power.

This newest rotator in the company's line is available in two control box styles. One model features an electric eye which flashes the position of the antenna while the second model incorporates the company's compass unit which gives accurate readings showing the actual position of the antenna at all times.

A data sheet covering both models is available from the company on request.

**FRINGE AREA ANTENNA**

The Radion Corp. of 1137 N. Milwaukee Avenue, Chicago 22, Illinois has developed a new unit for fringe area reception which has been designated the "Suburban Television Antenna", Model 2G10.

The company claims that this new packaged unit is quick and easy to install thus saving both manpower and time. The antenna is of all-steel construction with a baked on enamel finish. It is supplied with universal mounting brackets for window, roof, or attic installations.

**DEFLECTION YOKE**

The Electronic Parts Division of Allen B. Du Mont Laboratories, Inc., 35 Market Street, East Paterson, New Jersey has developed a new deflection yoke which is said to provide edge-to-edge sharp focus and increased sensitivity.

The new Series Y2A ferrite core deflection yoke features the company's distributed winding. It is designed for use with TV tubes of 60 to 70 degree deflection angle covering present popular tube types.

The yoke is available for use with transformer or autotransformer output circuits. It can also be supplied with different networks and lead lengths or without networks and

**LOW, LOW CHELSEA PRICES FOR HIGH, HIGH QUALITY TV**

for 17"  
Rectangular Tube  
LESS C R T

**\$132.90**

Including Fed. Exc. Tax

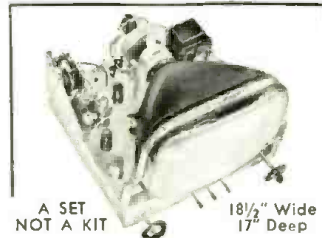

A SET NOT A KIT  
18 1/2" Wide  
17" Deep

for 20"  
Rectangular—or  
19" Round  
(Specify)  
LESS C R T

**\$143.40**

Including Fed. Exc. Tax

**FAMOUS C-4 CHASSIS HAS LATEST 1951 FEATURES**

- Completely wired • Superpowered with Noise-Limiter Circuit • Factory Engineered, Aligned and Tested • Improved AFC-AGC • Latest Single-Knob Control • 19 Tubes 13K Anode Voltage • Front End down to 45 Microvolts • Phono Jack Switch • Fine Reception, even on indoor antenna, in most areas.

**Full RMA Guarantee • Free Chelsea Warranty • Just Plug It In—It Works!**

Also Available 630 Type Chassis and Complete C-4 Sets In Table Or Console Models

17" Rectangular  
**\$34.95**

**EXTRA SPECIAL**

Guaranteed Factory-Fresh

← **PICTURE TUBES** →

in sealed cartons

(Prices include Federal Excise Taxes)

20" Rectangular  
**\$49.95**

**First Quality—VITAL COMPONENTS—Precision Tested**

(Prices include Federal Excise Taxes)

Number	Item	Price	Number	Item	Price
5-1	4.5 MC Ratio Det. Trans. . . . . .	\$1.05	5-11	Filter Choke 2H 190 MA 60 ohm. . . . .	\$1.05
5-2	4.5 MC Sound Take Off Trans. . . . .	.86	5-12	Filament Choke .9 ohm . . . . .	.07
5-3	Audio O.P. Trans. 6V6 to 3.2 ohm. . . . .	.77	5-13	Hor. Osc. Coil 20-40 MHY variable. . . . .	.54
5-4	Hor. O.P. Trans. HI EFF—similar to Gen. Electric Type 77 JI. . . . .	3.93	5-14	Width Coil 54-245 MHY variable. . . . .	.38
5-5	Vert. O.P. Trans. Turns Ratio 10:1 Primary 1300 ohm—Sec. 9.7 ohm. . . . .	1.55	5-15	Linearity Coil 5.5-20 MHY variable. . . . .	.43
5-6	Power Trans. 405 VDC-180 MA CT red-yellow. 6.3 V AC—6.15 A green . . . . . 6.3 V AC—1.2 A brown . . . . . 6.3 V AC—1.2 A slate . . . . . 5 V AC—3 A yellow. . . . .	7.29	5-16	Focus Coil 356 ohm 200 MA 70° . . . . .	3.93
5-7	Vert. Block Osc. Trans.—Turns Ratio 1:4.2 Primary 165 ohm. Sec. 1000 ohm . . . . .	.90	5-17	Speaker—5" 3.2 ohm . . . . .	1.35
5-8	40 Mfd 450 V Cond. Tubular. . . . .	.79	5-18	Speaker—8" 3.2 ohm . . . . .	2.70
5-9	100 Mfd 25 V Cond. Tubular. . . . .	.59	5-19	Ion Trap—single . . . . .	.32
5-10	4 Mfd 25 V Cond. Tubular. . . . .	.41	5-20	Phono Switch DPDT (slide). . . . .	.38
			5-21	Interlock TV line cord for popular makes . . . . .	.29
			5-22	High Voltage Condenser—500 mmfd 20 KV . . . . .	.69
			5-23	Focalizer for all type tubes . . . . .	2.49
			5-24	Deflection Yoke—wire iron ferrite 70° 13.8 MHY . . . . .	3.95

**HOW TO ORDER:** Phone and mail orders for chassis and tubes filled on receipt of Certified Check or M.O. for \$25 as deposit, balance C.O.D., F.O.B., N. Y. In ordering Components, specify Item No. and quantity. Send 25% deposit with order, balance C.O.D., F.O.B., N. Y., plus postage. (\$1.00 handling charge for orders less than \$5.00.) In N. Y. C. add 2% Sales Tax. Discount for volume orders. All items subject to prior sale—or to change of price—without notice.

**The House of Burgains**

**CHELSEA TELEVISION CENTER, INC.**

130 West 42nd Street, New York 18, N. Y. LONgacre 5-2254-5-6

**BECOME A RADIO AMATEUR**

Complete Home-Study Course for Passing FCC Amateur Radio Examinations

- LOW COST •
- PERSONAL COACHING •

Write for Details  
**FEDERAL ELECTRONICS INSTITUTE**  
45 East Putnam Ave., (Dept. D), Greenwich, Conn.

**NEW TV-RADIO TUBES** 100 TO 1000 LOTS  
6T8-12AU7-12AT7-12SA7 ETC.

**PARAMOUNT ELECTRONICS**  
734 N. LA SALLE ST., MOhawk 4-4085, CHICAGO 10, ILL.

**Communication Problems Solved WITH ARMY FIELD**

**TELEPHONE WIRE**  
All-purpose—all-weather

This is Genuine W110B Army Field Wire on original steel reels. Insulated, 2-conductor, copper-steel strands. Excellent for all types of communication. Used extensively by telephone companies, industry, engineering projects, ranches, public address systems, etc.

**GRADE 1**—New, unused, excellent condition.  
Mile reels (wt. 100 lbs.) . . . . . \$19.50  
Half-mile reels (wt. 50 lbs.) . . . . . 10.00

**GRADE 11**—New, unused, good condition.  
Mile reels . . . \$15.50 Half-mile reels . . \$8.00

**ACT NOW! LIMITED SUPPLY!**

All prices FOB Sacramento. No COD. (Calif. residents add 3% for sales tax.) Small orders sent post-free collect, heavy orders freight.

Write for **FREE FOLDER, Telephone Specialties.**  
Send check or money order  
**LORIS SALES**  
P.O. Box 1896-M5 Sacramento, Calif.

# RADAR, COMMUNICATIONS AND SONAR TECHNICIANS W-A-N-T-E-D For Overseas Assignments

## Technical Qualifications:

1. At least 3 years practical experience in installation and maintenance.
2. Navy veterans ETM 1/c or higher.
3. Army veterans TECH/SGT or higher.

## Personal Qualifications:

1. Age, over 22—must pass physical examination.
2. Ability to assume responsibility.
3. Must stand thorough character investigation.
4. Willing to go overseas for 1 year.

Base pay, Bonus, Living Allowance, Vacation add-up to \$7,000.00 per year. Permanent connection with company possible.

Apply by Writing to

D-4, P.O. Box 3575,  
Philadelphia 22, Pa.

Men qualified in RADAR, COMMUNICATIONS or SONAR give complete history. Interview will be arranged for successful applicants.

## BUILD YOUR OWN 5 TUBE SUPERHET RADIO

**\$295  
ONLY**

We furnish all but the components



• A Beautiful Plastic (Buterfine) Cabinet • A Copper Plated Chassis—Stamped for Mounting Parts • A Name Plate • A Calibrated Tuning Dial • A Volume Control Knob • A Stamped Jute Back • 3 Rubber Grommets • 4 Sheet Metal Screws—For Chassis and Back Mounting • 5 Miniature Tube Sockets \$1.00 All yours to get you started on your own radio. Back deposit with C.O.D. orders. You pay postage. Send only \$2.95 and we will pay postage.

## FOUNDATION KIT FOR THE NEW 1951 "MELROSE PAGODA"



**\$395  
ONLY**

### Less Components

• A Beautiful Plastic (Styrene) Cabinet • (Your choice in 5 pastel colors) • A "Cadmium" Plated Chassis to Match. (Stamped for Mounting various style and size parts) • Metal Dial Plate Etched in black numerals) • Pointer Knob and Matching Switch Knob • Filter Back and 4 Fasteners • Strain Relief Bushing for Line Cord • Black Plastic Handle and 2 Screws for Mounting • Black Chinese Pagoda Base and 2 Fasteners • Cadmium Plated Bracket for Variable Condenser Mounting • 5 Miniature Wafer Sockets and Rivets. This is not a discontinued model—but our latest 5 tube table model radio. Modern in design and color styling. Just out on the Market.

Check your choice of color:  White  Ivory  Green  Canary Yellow  Chinese Red

FREE Mounting of the following if desired, please check:  Pagoda Base  Spot Weld Var. Cond. Bracket  Rivet Wafer Sockets to Chassis

**THE LORMEL PRODUCTS, Inc.**

10408 Superior Ave. Dept. RT-5 Cleveland 6, Ohio

**CODE SENDING  
RECEIVING SPEED**

**HIGH SPEED WITHOUT  
NERVOUS TENSION**

REVEALING BOOK shows how "crack operators" develop high speed and proficiency. Learn code for Amateur or Commercial Radiotelegraph License, or improve your sending and receiving with the Candler System which develops radiotelegraph experts and code champions.

**CANDLER SYSTEM CO.** Denver, Colo. **FREE BOOK!**

Box 928, Dept. 246

leads. In several standard stock types it covers the requirements of technicians and set owners for improving existing equipment. For the service trade the yokes come packed in individual boxes, complete with installation instructions.

These yokes are designed to withstand continuous operating temperatures up to 90 degrees C and voltages up to 4 kv. between any windings or between windings and frame. Standard horizontal inductance is 10.5 mh. and vertical inductance is 42 mh.

## VIDEO PICTURE GENERATOR

Telechrome, Inc. of 88 Merrick Road, Amityville, Long Island, New York has announced the development of the

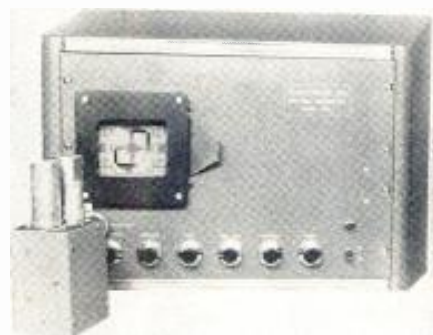

Model 300-A flying spot, low-cost television picture generator.

The new unit uses 3 x 4 inch slide transparencies, negatives, etc. and is designed to supplement or replace monoscopes, camera chains in TV stations, laboratories, factories, schools, and colleges.

The generator is completely self-contained with regulated power supplies. Resolution is greater than 500 lines and meets RTMA picture quality specifications. The unit will operate on standard driving pulses, off-the-air sync, or on self-contained sweep generators.

Details on the Model 300-A, which is supplied with a driven sweep 10" monitor, are available from the company.

## TWO-STAGE TV BOOSTER

The Mark Simpson Manufacturing Co., Inc., 32-28 49th Street, Long Island City, New York has just developed a



new two-stage television booster designed particularly for fringe area installations.

Known as the "Masco Super Sky-chief Booster," the new unit eliminates any overloading of the TV set by in-

**RADIO & TELEVISION NEWS**

**MAKE up to \$7,500<sup>00</sup> PER YEAR!**

**Now! GET YOUR  
F.C.C. LICENSE  
AMATEUR OR COMMERCIAL**

## TRAIN WITH SHORT-CUT PHOTOSOUND!

YOU GET AND KEEP 140 RECORDINGS  
The complete course is yours for less than the cost of the recordings alone. All records and study material become your personal property.

## E.T.I. INTRODUCES "AUTOMATIC" LEARNING

Amazing PHOTOSOUND lets you relax and LEARN WITHOUT STUDYING—by bringing your instructor right into your home. You just LOOK at the diagrams, etc., and LISTEN to the simple explanation. Turn records on and off at will. Repeat to your heart's content, until you've MASTERED the subject—your instructor never gets out of patience! No other course offers such ease and thorough instruction as "Photosound."

**HOME TRAINING—**  
as low as \$5 down, \$5 per month  
**RESIDENT TRAINING**  
**APPROVED FOR VETERANS**

\*VETS! YOU MUST ACT BEFORE JULY 25 to take advantage of the G.I. Bill

Get full details and three free booklets NOW!

**Mail Coupon**

**FREE**

**"OPPORTUNITIES IN ELECTRONICS"** **F.C.C. EXAMS MADE EASY** **SAMPLE F.C.C. EXAM**

**ELECTRONIC TECHNICAL INSTITUTE** Dept. RS-110  
769 Venice Blvd., Los Angeles 15, Calif.  
Gentlemen: please send me free of charge your three-in-one booklet, "F.C.C. Exams Made Easy", "Opportunities in Electronics" and "Sample F.C.C. Exam". I am interested in the F.C.C. AMATEUR ( ) COMMERCIAL ( ) Licenses.

NAME \_\_\_\_\_ AGE \_\_\_\_\_  
ADDRESS \_\_\_\_\_  
CITY \_\_\_\_\_ ZONE \_\_\_\_\_ STATE \_\_\_\_\_

corporating a two-knob control which makes it possible to utilize the amount of gain required.

In the "Off" position, the booster permits the TV set to operate through its direct connection to the antenna without booster action. The unit has 8 tuned circuits with uniform gain on all channels.

The booster is housed in a baked mahogany hammertone finished cabinet with a sloped dial panel.

#### A.C.-D.C. RECEIVER

The *Coleman-Grubb Company, Inc.* of 387 Fourth Avenue, New York 16, New York is handling distribution on a new model direct current television receiver which has been developed by *Gotham-Visionaire* especially for the d.c. consumer market.

The new set uses a 17" picture tube, has 27 tubes, and features a built-in antenna, four stages of i.f. amplification, steady high voltage power supply, and FM sound. The set can be operated in d.c. areas without the use of



inverters, vibrators, or motor generators. It is also designed to operate on a.c.

The receiver is currently available in a mahogany table model with console models scheduled for early production.

#### "RADARRAY"

The *Gonset Company*, 72 E. Tujunga, Burbank, California has added a new antenna to its line of fringe area equipment.

The new broadband, low channel array utilizes new principles which provide high gain and front-to-back ratio on Channels 2 through 6. Employing stacked colinear dipoles ahead of a duplicate dipole curtain which is connected in quadrature with all elements driving the feed point, the array is much less frequency sensitive than high gain arrays using parasitic elements.

While quite large physically in order to obtain the maximum practical gain, the array is ruggedly constructed to withstand icing and high winds.

#### NEW 20" TUBE

*Hytron Radio & Electronics Corp.*, Salem, Massachusetts has announced the availability of a new 20" direct-view picture tube, the Type 20FP4.

This rectangular screen unit, which has a standard 4 to 3 aspect ratio,

**Performance**

WHEREVER YOU ARE  
with *Telrex*  
"CONICAL-V-BEAMS"™

## America's Finest TV Antenna —

Telrex "Conical-V-Beams" are engineered to perform where others fail, whether near or far from the TV station.

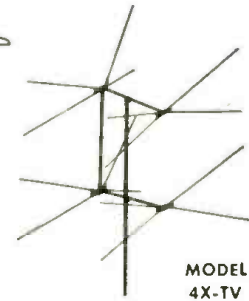

#### ACTUAL PERFORMANCE COUNTS!

It takes more than extravagant claims to produce results. That's why Telrex has over a million "Conical-V-Beam" installations all over the nation.

Install a "Conical-V-Beam" today — you'll be installing them every day thereafter because you can

\*REGISTERED TRADE MARK

"See the Difference"

Conical-V-Beams are Produced under Patent No. 2518297

*telrex* INC.  
CONICAL-V-BEAMS

AMERICA'S STANDARD OF COMPARISON  
ASBURY PARK 7, N. J.

THE SKILL TO DESIGN  
THE FACILITIES TO PRODUCE  
THE ABILITY TO DELIVER

**NOW!** At Hy-Grade! **the SKY-HIGHEST VALUE in Television Today!**

World Famous Quality  
**630**  
TV CHASSIS  
only  
**\$149.95** less CRT

Yes, you can believe your eyes! Here's the exact duplicate of the incomparable RCA 630TS Circuit—television's unmatched standard for super-sensitivity and stability—now with all the newest features of trigger-fast keyed AGC, Voltage Doubler, Standard Tuner, molded condensers, plus the finest quality components, Yoke, Focus Coil, Mounting Brackets, plus 30 tubes. Supplies 13 to 14KV under load for full brilliance and width for all rectangular and round 12½, 16 and 19" tubes. At only \$149.95 this is the TV super-value you can't afford to miss! Order several NOW! Immediate Delivery! 25% deposit with order, balance C.O.D., l.o.b., Brooklyn, N. Y.

for SKY-HY VALUES at rock-bottom costs— it's HY-GRADE!

**Hy-Grade Electronics, inc.**  
1509 EAST NEW YORK AVE., BROOKLYN 12, N. Y.

National Distributors of Electronic Parts and Equipment

\*\*\*\*\*  
**YOU CAN STILL**  
*Buy—*  
**TROUBLEPROOF**  
**TELEVISION**  
**THE 630 TV WILL WORK**  
**WHERE OTHERS FAIL!**

Own the Television Set preferred by more Radio and Television Engineers than any other TV set ever made!

**THE ADVANCED CLASSIC 630 TV CHASSIS**  
 With the latest 1951 improvements the 630 TV will out-perform all other makes in every way. The new, high efficiency, 30 plus tube circuit should not be compared to the cheaply designed 24-tube sets now being sold under standard brand names.

- **Greater Brilliance**  
 Assured by the new 14-16 KV power supply.
- **Flicker-Free Reception**  
 Assured by the new Keyed AGC circuit—no fading or tearing of the picture due to airplanes, noise or other interference.
- **Greater Sensitivity**  
 Assured by the new Standard Tuner, which has a pentode RF amplifier and acts like a built-in High-Gain Television Booster on all channels! The advanced 630 chassis will operate where most other sets fail, giving good performance in fringe Areas, and in noisy or weak locations.
- **Larger—Clearer Pictures—for 16", 17", 19" or 20" Tubes**  
 Assured by advanced circuits. Sufficient drive is available to easily accommodate any tube.
- **Trouble-Free Performance**  
 Assured by use of the finest materials such as quality condensers, overrated resistors, RCA designed coils and transformers, etc.
- **RMA Guarantee**  
 Free replacement of defective parts or tubes within 90-day period. Picture tube guaranteed fully for six months at no extra charge!

PRICE COMPLETE  
 LESS PICTURE TUBE .....NET **\$164.95**  
 NO ADDITIONAL TAXES TO PAY

**TELEVISION PICTURE TUBES**  
**Standard Brands**  
 SIX-MONTH GUARANTEE

12½" (Black or White) .....	\$26.50	Glass 16" Round (Black) .....	\$39.50
Glass 14" Rectangular (Blk.) .....	\$29.50	Glass 16" Rectangular (Blk.) .....	\$39.50
17" Rectangular (Blk.) .....	\$42.50		
19" Round (Blk.) .....	\$69.50		
20" Rectangular (Blk.) .....	\$73.50		

**TELEVISION CABINETS**  
**16" or 17" Table Model Cabinet**  
 A gorgeous table model cabinet for the average size living room. Outside dimensions 23¾" Wide x 24" High x 24" Deep.  
 Walnut or Mahogany..... **\$49.50**

**16" Economy Console Cabinet**  
 An exceptional buy in a console cabinet made of fine veneers to house the 630 TV chassis, tube and speaker. Outside dimensions are 39" High x 24" Wide x 22¾" Deep. **\$54.95**

**16" or 17" PERIOD CONSOLE**  
 Handsomely styled for the conventional living room. Has a drop-door panel to conceal control knobs when desired. Outside Dimensions are 41" High x 26" Wide x 24" Deep. **\$69.50**

Above cabinets available for 19" or 20" tubes at \$5.00 additional.

**NEW 400 CYCLE MOTOR GENERATORS!**  
 Holtzer Cabot type MG 218  
 Motor: 115 Volts DC. @ 2.3 Amperes, ¼ HP. 3430 RPM  
 Generator: 110 Volts A.C., 400 Cycles @ .1 Ampere  
 Complete with hash-fitters, etc..... Price \$49.90

All Merchandise Subject to Prior Sale. All Prices Subject to Change without Notice.

WRITE FOR COMPLETE CATALOG N-5  
**EDLIE ELECTRONICS INC.**  
 154 Greenwich St. New York 6, New York

utilizes electrostatic focus and magnetic deflection to provide a 17" x 12¾" picture.

An unusual feature of the new tube is its focusing method. It employs a focusing electrode of zero current design which allows the set designer to eliminate the entire magnetic focusing assembly.

The relatively flat face of the new tube incorporates a neutral density gray filter to increase the contrast ratio. The 20FP4 also features an electron gun designed to be used with a single magnet external ion trap magnet.

Full details on the 20FP4 are available from the company's Commercial Engineering Department.

**HIGH VOLTAGE CONDENSERS**

The Accessory Division of *Philco Corporation*, Philadelphia, Pa. has announced a new line of twenty-six condensers which have been designed specifically for high voltage, high temperature applications.

The new condensers, rated for dependable operation up to 85 degrees C., are housed in a newly designed molded phenolic casing which is humidity resistant, non-inflammable, and mechanically sturdy. Corona has been minimized in the electrical design of these units and a specially treated mineral oil has been utilized as the condenser impregnant.

The new line is available in working voltage ranges of 3000, 5000, 6000, and 10,000 volts d.c. Each condenser has a tolerance of ± 20%. These units are being handled by the company's wholesale distributors.

**GIANT TV LENS**

The largest lens for a Schmidt optical system ever to be manufactured commercially is in production at the *Polaroid Corporation*, Cambridge 39, Massachusetts.

Designed to provide a 15 x 20 foot



picture, the 22½ inch lens is cast from liquid plastic by means of a unique war-born technique developed by the company.

The new lens is to be used in an RCA theater television projection system.

the "High Quality"  
**AUDIO AMPLIFIER**  
*For the Critical Music Lover*

Model 10C3

- Handsome appearance
- ALL TRIODES for the utmost in naturalness.
- Exclusive Brook circuits & transformers.
- Listening fatigue reduced to a minimum.
- Inputs compensated for any type of phono-pickup, TV, FM & AM receiver.

Write for Technical Bulletin, detailed Distortion Analysis & booklet 'Better Listening'

**Brook Electronics, Inc., Dept. RE-1**  
 • • 34 DeHart Place, Elizabeth, New Jersey

**USE**

**KESTER**  
 FLUX-CORE

**SOLDER**

**FOR TV AND RADIO WORK—** Kester Plastic Rosin Core Solder and Kester "Resin-Five" Core Solder. Kester Solders are made from the finest grades of tin and lead commercially available.

**KESTER SOLDER COMPANY**  
 4235 Wrightwood Ave.  
 Chicago 39  
 Newark, N.J. Brantford, Canada

**KESTER SOLDER**

**RADIO & TELEVISION NEWS**

## Sound Engineering

(Continued from page 62)

impedance, for a given amount of power at the input, the level at the output of the amplifier will be lower by 2.22 db., as compared to the first transformer.

When one circuit is bridged by another, a loss of power will take place. This is termed "bridging-loss." If the bridging circuit impedance is high compared to that of the circuit bridged, the power loss will be small. To calculate the loss of power for such a condition, equation (7) is used:

$$db. = 20 \log_{10} \frac{2 Br + R}{2 Br} \quad (7)$$

where:  $Br$  equals the bridging resistance and  $R$  the circuit bridged.

As an example, assume we have a circuit of 600 ohms impedance and we wish to bridge it with a 7500 ohm vu. meter. How much power is lost? Substituting in equation (7),

$$db. = \frac{15,000 + 600}{15,000} = 1.04$$

$$20 \log_{10} 1.04 = 20 \times 0.0171 = 0.342 db.$$

If the original level in the 600 ohm circuit was a plus 4 dbm., bridging the meter across it will reduce the level 0.342 db. The true level is now plus 3.658 dbm.

In dealing with a device such as an attenuator, which provides a net loss of power, the output power will always be smaller than the input power. In this case, it is more convenient to invert the power ratios, voltage ratios, or other such factors, in order that we may deal with numbers larger than one. If this method is used, the calculations will result in positive values, the same as for a gain calculation.

In the use of logarithms, the characteristics are:  $1 = 0$ ,  $10 = 1$ ,  $100 = 2$ ,  $1000 = 3$ , etc. Given a power ratio of  $1000/1$  it would be evident that  $10 \log_{10}$  for this ratio would be  $10 \times 3$  or 30 db. Or, when the voltage or current ratio is given it becomes  $20 \times 3$  or 60 db. Table 1 illustrates how widely divergent ratios may be calculated easily by inspection.

Fig. 1 is a diagram of an amplifier and the various formulas that may be used to determine its gain, depending on known factors and whether the input and output impedances are equal or unequal in value.

Several different methods may be used for defining and computing gain or loss. These methods differ only in the way the reference power and the one to be compared are chosen. The method used depends largely on the circuit conditions, impedance, and how the gain or loss of other units in the system have been computed.

In making an analysis of the characteristics of an amplifier the gain may be calculated for the amplifier as a whole or for a single or group of stages.

The difference in level for two cir-

## EVERYONE WANTS AN "ORIGINAL"



A copy is never as good as the original. That's why TRIO TV Antennas are "wanted" antennas. TRIO has consistently led the industry in developing better, more efficient antennas. Never "just like" another, every new TRIO model is original and represents an improvement over any existing TV antenna.

\* Patent Pending — No licensing arrangements granted for duplicating principle of this antenna.

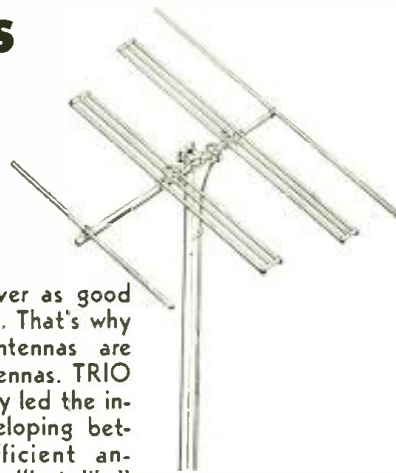

\* MODEL 445, the famous Single-bay TRIO Yagi for TV channels 4 & 5. Supplied less mast and transmission line.

### TRIO YAGI SETS THE PACE

An example of TRIO's original design is the amazing dual channel TRIO Yagi — a single-bay 4 element yagi that provides full 10 DB gain on two channels! Available for channels 4-5 and 7-9, this revolutionary antenna makes bulky stacked arrays obsolete by providing excellent fringe area TV reception where other antennas fail!

### HOW IT WORKS

Antenna consists of 4 elements whose function is different on the two channels. For example: in Model 445, the elements, on channel 4, act as reflector, dipole, director, director, in that order; while on channel 5, the same elements act as reflector, reflector, dipole and director. Careful design insures proper impedance match with standard 300 ohm lead.

### COMPARE THESE ADVANTAGES

- Provides gain on both channels 4 and 5 (or 7 and 9) Equal to Any Two conventional 4-element yagis!
- One bay replaces bulky stacked array!
- One lead replaces old-style 2-lead systems!
- Less weight-per-gain than any other TV antenna!
- Greatly reduced installation costs for complete TV coverage!
- Can be stacked for additional gain.

Model 445. Single or stacked Yagi for Channels 4 & 5.

Model 479. Single or stacked Yagi for Channels 7 & 9.

Model 645. "Controlled Pattern" System consisting of 2 bays offset stacked and "Phasitron." Eliminates co-channel interference. For Channels 4 & 5.

Model 679. "Controlled Pattern" System for Channels 7 & 9.

Model 304. Single Channel Yagi with Double Dipole for Channels 2 to 13.

Model 604. Same as Model 645 except for single channel operation.



\$\$\$\$\$\$\$\$\$\$\$\$\$\$\$\$

## WE PAY CASH

for all types of

### RADIO, RADAR, ELECTRONICS OR GOV'T. SURPLUS EQUIPMENT

Regardless of condition. Top dollars for:

- ART-13 Xmitter
- DY-17 Dynamotor
- TS-12 Test Sets
- TS-13 Test Sets
- Signal Generators
- Microvolters
- 1-100 Test Sets
- BC-348 Rcvr. (AC or 28 V)
- BC-788C Trans.-Rcvr.
- 1-152C Indicator
- Lab. Test Equipment

Plus anything and everything you have in Electronics Equipment. Send description and asking price to:

**WEST REGION ELECTRONICS**

New correct address (if your correspondence was returned, remit to):

Dept. VI  
1437 S. Norton Ave., Los Angeles 19, Calif.

## ORDER NOW!

THIRTEENTH EDITION

# RADIO HANDBOOK

READY IN JUNE

Our greatest (and biggest) radio text. MORE PER-DOLLAR VALUE than ever before! Theoretical, reference and constructional information on all aspects of radio communication.

OVER 720 PAGES OF TEXT!

Don't wait! For one of the first copies off the press, order now! \$6.00 at your dealer; by mail from us, \$6.25; foreign, \$6.50.

**EDITORS AND ENGINEERS, LTD.**

1302 Kenwood Road Santa Barbara, Calif.

# Columbia

GEM OF THE SURPLUS

**BC-604-FM TRANSMITTER:** 30-28 mc. 11 and 15 meters. Ideal for C.D. Can be put on 10-meter, 10-channel, push-button control. Complete with tubes and dynamotor. Used. Excel. cond. . . . . \$25.95

**PROP PITCH MOTORS:** Rotate your beam antenna with these like-new motors. 20-30 V. AC-DC. Half h.p. motor rotates 1 1/4 ft.-m. with terrific torque. Used. excel. cond. . . . . \$9.95  
BRAND NEW . . . . . \$12.95

**DYNAMOTORS**  
BD-77 12 V. input 1000 V. 350 mils. Used, good cond. . . . . \$9.50

**STARTER:** 2 V. wet cell. Series them up to your requirements. NEW. EACH. . . . . \$1.50  
ORDER 3 FOR ONLY . . . . . \$3.99

**APN-1 ALTIMETER-TRANSCIVER:** Operates approx. 420 mcs. band or citizen's band FM. Excellent cond. With schematic . . . . . \$6.95

**OIL FILLED CONDENSERS**  
2 x .15 mfd. 800V VDC . . . . . \$8.00  
2 x .1 mfd. 700V VDC . . . . . 7.50  
.02 mfd. @ 2000 VDC . . . . . 1.79  
2 mfd. @ 600 VDC . . . . . .98

**BATHTUB CONDENSERS**  
2 x .1 mfd. @ 400 V. . . . . .39c  
3 x .1 mfd. @ 400 V. . . . . .39c  
4 mfd. @ 400 V. . . . . .39c  
.5 mfd. @ 400 V. . . . . .49c  
.1 mfd. @ 600 V. . . . . .49c  
.01 mfd. @ 600 V. . . . . .49c  
.5 mfd. @ 600 V. . . . . .49c  
2 x .1 mfd. @ 600 V. . . . . .49c

**HS-30 HEADSET:** Used. Excel. cond. . . . . .95c

**TUBES! STOCK UP WHILE U CAN!**

713B	\$ 8.95	6SN7	\$2.00
C5B	9.95	6AC7	2.50
2102	34.95	6H6	.89
2122	49.95	6E5	1.65
703A	2.49	12AT6	1.50
701	3.95	12SJ7	1.65

**Ahoy! Marine Gear Specials! Look Alive!**

**BOAT OWNERS! COLUMBIAN MARINE TRANSMITTER:** Kill your transmitter trouble once and for all! Check these outstanding features! 12 or 24 V. optional. 120 W. output rated at 100% modulation. 4-channel, xtal control. 400 ft. range. WILL MATCH ANY ANTENNA! FCC approval guaranteed. Dimensions: 11 1/2 x 13 1/2 x 1 1/2 inches. COMPLETE with dynamotor, cord, mike, tubes, pre-tuned and ready to go. We got it cheap, so we're selling it cheap!

**ONLY \$249.00**

**BC-375 TRANSMITTER**  
With TU-5 for marine use. 100 W. 24 V. input. Excel. cond. . . . . \$18.90

**COMPLETE ARN-7 MARINE ADF COMPASS**  
DON'T GET LOST AT SEA! Includes 24 V. inverter, loop, compass, indicator, control box, receiver, plugs, flex cable and rack. Excel. cond. ONLY \$89.95

**JEFFERSON-TRAVIS "Emerson Radio Corp." RADIO TELEPHONE:** 5 W. marine. This is it. Brand new. NOT STUBBY. Small boat gear for emergency stand-by. Small boat gear. Covers 200 yds. xtal controlled. Ship-to-ship and ship-to-shore. Has a 4 hr. light or will run 8-10 hours on its own self-charging 6 V. battery pack. Needs no special installation. A kid can operate. Has long speaking tube. Unit comes in small metal case with carrying handle. Size 10 1/2 x 8 x 3 1/2 inches. Wt. 30 lbs. Complete with mike, 11 1/2 hr. recharging unit, instructions, and 90-day factory warranty. Ready to go. Less xtal and battery \$79.50  
CRYSTALS—2 pr. needed, specify frequency. Each \$4.00

**MN-26C RECEIVER:** Freq. 150-1500 kc. 28 V. with control box, flex. cables, azimuth indicator, loop, and loop cable. Extra hot for aircraft or marine use. Most parts brand new. 15 1/2 x 11 1/2 x 11 1/2 in. \$34.95

**TS-16 APN SIGNAL GENERATOR:** Used with radio-aircraft altimeter for checking and aligning sets. Complete. Excel. cond. . . . . \$39.95

**METERS! THE BEST BUYS IN THE BOOK!**  
0-3 VDC 2 in. round, Simpson . . . . . \$2.49  
0-15 VAC 3 in. round, Weston or Roller Smith . . . . . 3.29  
0-50 amp. AC 2 in. square, Triplet . . . . . 2.99  
0-25 MADC 2 in. round, Weston or will run 2.99  
0-2 amp RF 2 in. round, Thermocouple type. 2.99  
0-8 amp RF 2 in. round, Westinghouse . . . . . 2.99  
**CONTROL UNIT C-78/APN-1** complete with 0-1 mil movement with 0-200 scale. Box contains 2 toggle switches, control knobs, panel light, etc., all for only! . . . . . 4.50

**ARC-5 OR 274-N TRANSMITTERS COMPLETE**  
2-1.3 mcs. Excel. for ship use . . . . . \$12.95  
3-5.3 mcs. Used. excel. cond. . . . . 3.95  
3-5.7 mcs. Used. excel. cond. Less xtal . . . . . 4.50  
7-9.1 mcs. Used. excel. cond. Less xtal . . . . . 10.95

**ARC-5 OR 274-N RECEIVERS**  
3.6 mcs. excel. cond. . . . . \$ 4.95  
6-9.1 mcs. excel. cond. . . . . 12.50  
100-250 kcs. excel. cond. . . . . 7.95  
Command Receiver 28V dynamotor . . . . . 7.95  
MD7/ARC-7 Plate Modulator. Less 800 . . . . . 7.95

**274-N ANTENNA RELAY BOX**  
Contains RF meter plus 50 mfd H. V. vacuum cond. and relay. New in carton. . . . . 2.95

**APN-4 INDICATOR:** Makes swell foundation for scope. Comes with 5" tube and shield. Put tubes in to make ideal FPI marine radar. Complete, less tubes and crystal. Excel. cond. New Low Price. . . . . \$9.95

**HAMS! HIGHEST PRICES PAID FOR CLEAN EQUIPMENT. TELL US WHAT U HAVE.**

All orders F.O.B. Los Angeles. 25% deposit required. All items subject to prior sale.

**COLUMBIA ELECTRONIC SALES**  
522 South San Pedro Street  
LOS ANGELES 13, CALIFORNIA

circuits of unequal impedances may, when the voltages are the same, be determined by the use of equation (8):

$$db. = 10 \log_{10} \frac{Z_1}{Z_2} \dots \dots \dots (8)$$

A typical case where equation (8) would be used is given below. Assume we have two circuits, one 500 ohms and the other 250 ohms. What is the difference in level across the 500 ohm circuit in db., compared to the 250 ohm circuit, for a given voltage?

$$db. = 10 \log_{10} \frac{Z_1}{Z_2} = 10 \log_{10} \frac{500}{250} = 2.0$$

$$10 \times \log_{10} 2 = 10 \times 0.301 = 3.01 \text{ db.}$$

If the output level of an amplifier is stated in decibels and it is desired to convert it to watts output, equation (9) is used.

$$P = \left( \text{antilog} \frac{db.}{10} \right) \times \text{Reference level} \dots \dots \dots (9)$$

To illustrate the use of this equation suppose we have an amplifier which has a measured output level of plus 30 db. (6 milliwatt reference level). Substituting in equation (9):

$$\left( \text{antilog} \frac{30}{10} \right) \times 0.006 = (\text{antilog } 3) \times 0.006 = 1000 \times 0.006 = 6 \text{ watts}$$

Equation (9) is used only for positive values of db. For negative values, equation (10) is employed.

$$P = \frac{\text{Reference Level}}{\text{antilog} \frac{db.}{10}} \dots \dots \dots (10)$$

Fig. 2 is a block diagram of a typical recording system which is designed to illustrate the wide range of levels encountered, and how the decibel is employed to determine the operating levels at various points in the system. Above each block is given either the gain or loss of the device in decibels. Also, at various points in the circuit are shown the operating levels, which are created by the gain or loss of devices, such as the mixer, filters, master gain control, recording equalizer, and the amplifiers.

It will be noted that the output level of the microphone at the left is a minus 53 dbm., while the input level to the disc recorder cutting head at the right, is a plus 30 dbm. These levels indicate that a net gain of 83 db. will be required between extremes.

Starting at the left of the diagram, a microphone has been selected which has an average output level of minus 53 dbm. at 1000 c.p.s. This is followed by a preamplifier of 40 db. gain. The preamplifier raises the output level of the microphone to a minus 13 dbm., which is fed into the mixer input.

The mixer introduces two losses into the circuit. The first, which is fixed and created by the resistive network of the mixer, is called the "insertion loss." A second is created by the attenuation of the mixer pot which, for this example, is 15 db. These two losses

# TV DX

## is our business!

from BOSTON  
from PHOENIX  
from SEATTLE  
from NEW YORK  
from EVERYWHERE!

come unsolicited enthusiastic letters by dealers, installers and users reporting sensational results on the new

### GONSET LOW CHANNEL RADARRAY

"We have tried them all and your antenna outperforms them all."

There are good, sound technical reasons for the superior performance of the . . . . .

### GONSET LOW CHANNEL RADARRAY

Users are interested in results, and it is the high gain and high front-to-back ratio on all the low channels that is making converts of confirmed "antenna cynics." For unexcelled performance on all the low channels (2 through 6) you need but one antenna, if it is a . . . . .

### GONSET LOW CHANNEL RADARRAY

Engineered and manufactured by pioneer fringe area antenna specialists. Write today for brochure describing this and other fringe area antenna products, such as the GONSET HIGH CHANNEL RADARRAY and GONSET LINE (ultra low loss open-wire line).

**GONSET CO., BURBANK, CALIF.**

MIDWEST

Presents its NEW 1951

Line of TELEVISION

and RADIOS

Mammoth

19 1/2

INCH

PICTURE

TUBE

30 DAYS TRIAL

Don't buy any radio or television receiver until you've seen the new 1951 Midwest line - it's the best in 31 years.

FACTORY-TO-YOU

SEND THIS COUPON ON 1c POST CARD FOR NEW 1951 FREE 4 COLOR MIDWEST CATALOG

MIDWEST RADIO & TELEVISION CORP.  
Dept. 37-M, 909 Broadway, Cincinnati 2, Ohio

NAME \_\_\_\_\_  
ADDRESS \_\_\_\_\_  
CITY \_\_\_\_\_ ZONE \_\_\_\_\_ STATE \_\_\_\_\_

EASY TERMS



result in a total loss for the mixer of 35 db.

A booster amplifier with a gain of 30 db. is connected at the output of the mixer to compensate for the losses incurred by the mixer. Following the booster amplifier is a master gain control, with an average loss of 20 db. Two filters, a high-pass and a low-pass, follow next. In the filter passbands the insertion loss is one-half db. for each, or a total of 1 db. for the two. A line amplifier follows the filters with a gain of 43 db.

At the output of the line amplifier is a bridging bus, operating at a level of plus 4 dbm. This bus feeds a monitor amplifier and speaker, operating at an output level of plus 23 dbm. Also fed from the bus is a bridging amplifier, recording equalizer, and power amplifier, the three devices being in tandem, for driving the disc recorder cutting head. The gain of the bridging amplifier is 18 db., and is equivalent to the loss of the recording equalizer which is 18 db.

The purpose of the bridging amplifier is to make up for the loss created by the recording equalizer, therefore, the level at the output of the equalizer is the same as the bridging bus, a plus 4 dbm.

The gain of the recording amplifier must be sufficient to raise a level of plus 4 dbm. to a plus 30 dbm. Consequently, the gain of the amplifier must be 26 db. Using the same reasoning, the monitor amplifier must have a gain of 19 db. for an output of 23 dbm.

To determine the net gain of such a system between the output of the microphone and the input of the cutting head, all the gains are added, which amounts to a total of 157 db. Adding the losses gives a total of 74 db. Subtracting the total loss from the total gain gives a net gain of 83 db. This is the amplification required to secure a plus 30 dbm. at the cutting head, for a signal of minus 53 dbm. at the output of the microphone. In other words, if we substitute a minus 53 dbm. signal of 1000 c.p.s. for the microphone, we would obtain a signal of plus 30 dbm. at the cutting head for the conditions set forth.

A tabulation of the various gains and losses and how they are added is shown in Table 2. The methods used for determining the operating levels for recording systems will be discussed in a forthcoming issue.

(To be continued)

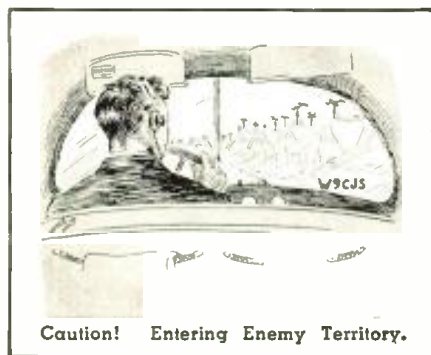

May, 1951



Model 60X Crystal  
\$10.85 List



A new Turner unit for hand, desk or stand use. Designed especially to meet all competition where good quality speech reproduction is required and low cost is important. A natural for hams, economical public address and sound systems . . . an ideal microphone for home recorders. Attractive case finished in baked on beige wrinkle enamel. Compare the Turner "COMPETITOR" with any microphone in its class and you'll agree that dollar for dollar it's a terrific microphone value.

Model 60X Crystal. Response: 70 to 7000 c.p.s. Level: 52 db below 1 volt/dyne/sq. cm. Moisture sealed crystal. Complete with 6 ft. cable and stand adaptor ..... \$10.85 List  
Model S60X Crystal. With on-off slide switch ..... \$12.85 List  
Write for Complete Details.

## THE TURNER COMPANY

900 17th Street N.E. Cedar Rapids, Iowa  
In Canada: Canadian Marconi Company, Toronto, Ontario and Branches  
Export: Ad. Auriema, Inc., 89 Broad Street, New York 4, N.Y.



Microphones BY TURNER

Crysta's licensed under patents of the Brush Development Company



Get  
EMERGENCY BAND  
CALLS At Home!

**POLIC FM ALARM**  
RADIO APPARATUS CORPORATION

DEPT. RN-5, 310 FOUNTAIN SQUARE THEATRE  
BLDG., INDIANAPOLIS 3, INDIANA

• Many fans spend hundreds of happy hours listening to city and state police calls on their Polic-Alarm radios. Polic-Alarm Model PR-31 is a quality radio which will give years of trouble-free service on the 30-50 mc. band. Can be used on either AC or DC current of 115 volts.  
Besides police calls, the 30-50 mc. band also is used by fire departments, ambulances, border patrol, forestry, maritime, railroads, bus lines, and other services. Enjoy the thrill of listening to these vital messages \$44.95 at home. Model PR-31 (illustrated)  
Polic-Alarm Model PR-8 is available for 152-162 mc. band reception. \$44.95  
Price, complete.....

145

# RADIO Surplus Buys

## CRYSTALS

... in FT 241-A Holders-  
1 1/2" Pin SPC. Marked in 54th  
OR 72nd Harmonic MC Freq.  
Listed below by fundamental  
frequency with fractions omit-  
ted.

412	433	472	492	390	402	372	381	450	530
413	434	473	493	391	403	374	383	452	531
414	435	474	494	392	404	375	384	461	533
415	436	475	495	393	405	376	386	465	537
416	438	479	503	394	408	377	387	465	538
418	440	481	504	395	409	379	388		
419	441	484	507	396	411	380			
420	442	485	509	401					
422	443	487	511						
423	444	488	516						
424	446	490	518						
425	447	491	519						
426	448								
427	462								
429	468								
431									

**79c**  
Each  
Postpaid

**39c**  
Each  
Postpaid

**99c**  
Each  
Postpaid

### CONTACT MIKE ASSEMBLY BRAND NEW!

Complete Contact Mike Assembly includes: Two micro-phones, on-off switch, amplifying transformer, batteries, battery case, Connector to attach to any radio. AC, DC or battery portable. Amplification up to full volume output of radio or sound system used. PB for watch or clock repair. Diesel engine injector adjustment, gas engine diagnosis, etc. Specially Priced at..... **\$3.95** Postpaid



### BLACK LIGHT KITS ULTRA-VIOLET FLUORESCENCE

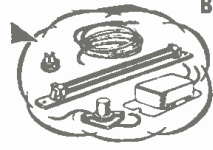

NOW... build your own black light equipment at a new low cost with these easy-to-assemble components. KIT contains: Ultra-violet tube, brackets, ballast, starter, wiring and diagrams.

- 4-Watt Kit—(5 1/2" tube).....\$3.00 ppd.
- 8-Watt Kit—(12" tube).....\$4.00 ppd.

### TUNER FROM NAVY "BN" EQUIPMENT

Simply modified into 2-meter converter for car or communications receiver. Uses 1-6J6, 1-68H7, 1-900E, 1-6D5 (Not Furnished). Slug is tuned from 157 to 187 Megacycles. Includes schematic diagram for "BN" equipment. A Real Value..... **\$6.95** ONLY

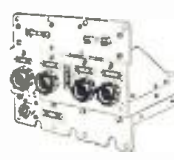

### RU-16 RECEIVERS UNUSED QUANTITY AT \$5.95



### POWER TRANSFORMER

Primary 125 volts tapped at 105 and 115 volts, 50 to 425 cycles. Secondaries: 5.1 v. at 3.0 amps, 325-0-325 v. at 0.175 amp., 5.4 v. at 8 amp., 6.4 v. at 10.3 amp., 2.5 v. at 3.0 amp., 4500 v. at .005 amp., 2.5 v. and 4500 volt windings insulated for 6000 volts. All other windings insulated for 1500 volts. Cost government more **\$4.95** than \$42.00—a real bargain!



### METERS, AIRCRAFT 1-Milliampere, zero center F1B for field strength meters, grid dip or tuning meters. BRAND NEW. Postpaid \$1.95

- PROP PITCH MOTORS, FOR BEAM AN. TENNA. BRAND NEW.....\$12.95
  - BC 603 RECEIVERS: Good Used.....\$22.95
  - BC 683 RECEIVERS: Good Used.....\$38.50
  - BC 604 TRANSMITTER: Good Used (less dynamotor).....\$17.95
  - BC 684 TRANSMITTER: Good Used (less dynamotor).....\$19.95
  - BC 923 RECEIVER: Good Used (less crystal).....\$38.50
  - BC 924 TRANSMITTER: Good Used (with tubes and dynamotor).....\$19.95
  - CRYSTALS FOR BC 604 TRANSMITTER: (Set of 80 crystals).....\$19.95
  - CRYSTALS FOR BC 684 TRANSMITTER (set of 80 crystals).....\$24.95
  - ARC-4 (Complete with tubes and dynamotor).....\$35.30
- ALL EQUIPMENT F.O.B. PASADENA UNLESS OTHERWISE SPECIFIED. PLEASE ENCLOSE FULL AMOUNT WITH ORDER

## C & H SALES CO.

Box 356-N East Pasadena Station, Pasadena 8, Calif.

## Pricing Service (Continued from page 48)

decent price schedules that represent an over-all profit.

The end result is that while these small shop owners have overhead expenses that are as inevitable as those of larger shops their overhead is too often paid for out of the small shop owner's own "wages," spread over a period of time.

If the small shop owner does not keep adequate books—and he usually does not—he is totally unaware of the huge sums of money dribbled away in the course of the year for a hundred and one overhead items.

If the new shop owner starts out with considerable capital saved from his wage earning days, he may acquire a new truck that involves no particular expense for the first year or more, except gas and oil and, perhaps, a tune-up or two. So, he figures his transportation is costing him only a dollar or two a day business expense. What, says he, is this nonsense about big overhead?

Yet, there must come a day of reckoning when he has a \$200 or \$300 complete overhaul job. That expense comes out of his own pocket because he has not charged enough overhead to jobs done, and long since completed and paid for, while the truck was building up to this expensive overhaul item.

Meantime, his truck is depreciating in value. If it cost him \$2500 when he acquired it, and it is depreciating at the rate of \$500 a year or more, this means an additional transportation expense of \$1.67 a day. What has actually happened is that he has prepaid or advanced this daily expense at time of setting up in business and purchasing the truck.

This situation won't catch up with him for several years. Finally, one day he'll wake to the realization that he has a broken down jalopy on his hands. His initial investment is gone and he has not set aside reserves each year to replace this worn-out truck. Even if aware of the eventual need for a truck replacement, he has not charged enough for his service to make a reserve fund possible.

The same thing is happening to his shop equipment and one day he will have a failing business with a job-lot of broken down and obsolete equipment.

Moreover, because, as his little classified ads boast: "I do my own work," he doesn't have the protection he used to have when he worked for wages. He is not covered by unemployment insurance, which he is going to need some day, thanks to his unbusiness-like methods. Neither is he covered by workmen's compensation. In soliciting work he frequently explains to prospective customers that, because he doesn't need to pay out such expenses on himself, he can work more cheaply. Can he?



## NEWCOMB SOUND IS BETTER

- Manufacturers of public address, mobile, phonograph, musical instrument and wired music amplifiers • Portable systems • Portable phonographs and radios • Transcription players • Rack and panel equipment.
- Write today! Circle items of interest and indicate whether you are a Dealer, Parts Jobber or Sound Specialist.
- NEWCOMB AUDIO PRODUCTS CO. DEPT. F, 6824 LEXINGTON AVE. HOLLYWOOD 38, CALIFORNIA

FAST, EASY QUICK RIG!  
MATCHES 300 OHM IMPEDANCE!

STURDY, TROUBLE-FREE CONSTRUCTION FOR LONG LIFE!

NEW!  
SENSATIONAL GAIN!  
**PHOENIX YAGI**

LICKS INTERFERENCE FROM GHOSTS AND NOISE!

**PHOENIX ELECTRONICS INC. LAWRENCE, MASS.**

Comes a day when he falls from a roof while installing an antenna and is injured on the job. His income stops and he and his family face stark tragedy. Why? Because his customers have had the benefit, in lower contract prices, of the insurance protection he failed to have on his own person.

Actually, the one-man shop owner or, for that matter, the owner running a crew of men, is as much entitled to hedges against accidents and sickness, unemployment and old age benefits as is the wage earner. He is being a sucker if he doesn't have this protection. By charging to jobs a percentage for such protection, just as he does where he employs technicians, he will be able to carry an accident and sickness policy on himself and lay aside funds over the years for his old age, or pay on an annuity. While he cannot enter this as a cost of doing business, or deduct it in his income tax return as a business expense, he is certainly entitled to enough profit to make such insurance and savings possible.

The small shop owner, in establishing prices and making service charges, should set his sights higher. Even if he does not fully attain his objectives immediately, he will certainly better himself to some extent. He should not only figure to recover his own labor at the going rate, but he should attempt to make enough to cover his own personal protection against the hazards of life in the same way a wage earner is now covered. In addition he should find out what his real overhead is.

Finally, he should add a reasonable percentage for net profits. That is, a real job profit should be his after everything else is paid for. This is an amount to which he is entitled.

Unless and until the small shop owner adopts such a course of action and sticks with it, he stands an excellent chance of closing each year's business with less net earnings than he would have working for wages, even though he may not immediately be aware of this fact, thanks to inadequate bookkeeping.

It is this writer's firm conviction that practically no shop owners price below cost for service from a desire to under-cut, as such. Almost invariably where cut-throat prices exist they come about from a lack of understanding of all the cost factors borne by the shop owner.

When the under-pricing shop owner adopts correct pricing procedures that reflect all of his overhead charges and permit a profit, he will no longer have the stigma of being an unfair competitor. And he won't have a class of trade made up of the chiseling fringe of his community. He will be gradually building up a type of trade where a profit is possible on every job. That's the only kind of business that holds any future for him. That's the invariable course followed by small shop owners who, today, have grown to large ventures enjoying the respect of their home towns.

**FINEST FOR FRINGE AREA RECEPTION—1952 MODEL**

**30 TUBE 630 CHASSIS**

LIC. UNDER  
RCA PAT.

ADAPTABLE FOR COLOR

**THE PERFECT  
CHASSIS FOR**

**16"-17"-20"-24"**

**PICTURE  
TUBES**

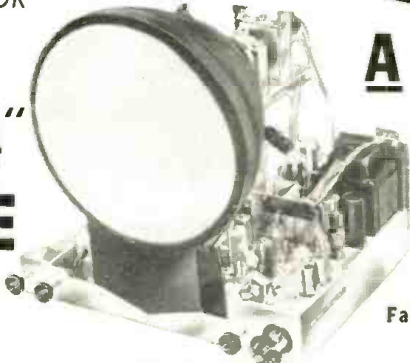

**A SET**

CHASSIS  
MOUNTING  
BRACKETS  
FOR TUBE  
**\$495**

**RMA &  
AIREX**  
Guarantee  
Factory wired,  
aligned &  
tested.

**\$159<sup>95</sup>**

With Hi-gain Standard  
Coil Tuner and RCA  
Hi-Fi 12" Speaker  
Complete with Fed. Taxes  
LESS CATHODE TUBE

Thousands of our 16", 17", 20" and 24" sets are giving new viewing thrills to TV-watchers all over the country. This extra powerful super chassis is designed to bring in sharp, clear pictures, even in fringe areas. Works in most areas on only an indoor antenna. Has Improved Keyed AGC; Full 4 Mc. Cycle Band Width; 16 KV output; 3 stage SYNC Separator & clipper; Moulded Plastic Condensers; Uses new Mark Transformer; 5-hour Min. Heat Run at Factory; Improved high gain front end, down to 45 microvolts; Synchro Lock; Freedom from arcing & corona leakage; Armstrong FM Sound System; Improved linearity adjustment & second horizontal linearity control. Phono connection and switch for record player on chassis.

AVAILABLE with DUMONT INPUTUNER FM RADIO & **\$169<sup>95</sup>**  
RCA 12" SPEAKER



**\$89.95**

**A PRICE-SMASHING  
VALUE IN TV  
CABINETS FOR  
THE 630 CHASSIS**

Full Doors for  
16"-17"-19",  
20" & 24"  
Picture Tubes

Without Doors  
for 16", 17",  
19", 20", 24"  
Picture Tubes

Beautiful, richly finished, hand rubbed mahogany cabinets specially designed to house the 630 chassis with a 12" speaker. A perfect picture deserves a perfect cabinet. It will be a focal point of beauty in your home. 40" high x 24" x 24". All complete with brackets, mast & hardware. Above cabinets in blond—\$10 EXTRA. Other models in stock. Send for circular.

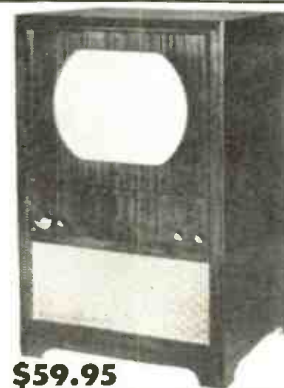

**\$59.95**

REGENCY BOOSTERS—\$19.87

12" RCA HI-FI SPEAKER—\$5.95

**TV TUBE SCOOP**

All Black, Glareless  
Sheldon, Zetka & TRL

14" rectangular ..... \$24.95  
16" rect. or round ..... 37.50  
17" rectangular ..... 39.50  
20" rectangular ..... 57.95

Also 24" RECTANGULAR  
All Tubes Fully  
Guaranteed for 6 Months

DuMont TV Tubes  
in Stock

**RCA, SYLVANIA, PHILCO**

Receiving Tubes—to 40% Off

1B3	8CD6	1T4	6J5
1X2	6K6	354	6SH7
3V4	6X7	3D4	6T8
5V4	6W4	5Y3	6X5
6AC7	7N7	6AG5	12AU7
6AK5	12BA7	6AL5	12SQ7
6AQ5	12SK7	6AU6	12SQ7
6AU6	25L6	6AV6	25Z6
6BC5	50A5	6BG6	50L5
6BL7	12AT7	6BQ6	12BA6

All Other Types in Stock

**RECORD CHANGER**

SALE  
WEBSTER 3-SPEED  
**\$32.95**

Plays 12 records automatically. All sizes. All speeds. 33 1/3-45-78 RPM. Permanent point needle.

In original carton. Reg. \$48.00



All merchandise is brand new, factory fresh & fully guaranteed. Mail & phone orders filled upon receipt of certified check or money order for \$25 as deposit on TV chassis, 20% on other items. Balance C.O.D., F.O.B., N. Y. Prices subject to change without notice. No additional taxes to pay.

**AIREX RADIO CORP.**

171 WASHINGTON ST., N. Y. C. 7, N. Y.  
WOrth 2-4029; WOrth 2-9576

THE JUNE ISSUE OF

**RADIO & TELEVISION NEWS**

will be on sale June 1st. Be sure to reserve your copy with your Newsdealer.



**COLOR TONE  
ON  
YOUR  
TELEVISION**

Simply attach TELECOLOR FILTER to front of set and enjoy favorite programs in wonderful glorious color tones instead of dull black and white. TELECOLOR FILTER is one of the latest discoveries, its special formula coloring gives brilliant, pleasing, genuine color tone, lifelike color depth, reduced eyestrain and glare. See our April ad—page 78—Free Information! Write Dept. RN-5.

HARVARD LABORATORY • 659 FULTON STREET • BROOKLYN 1, N. Y.

ORDER BY MAIL:  
10 inch. .... \$3.00  
12, 14 inch. .... 4.00  
16, 17 inch. .... 6.00  
19, 21 inch. .... 10.00

Learn Circuits from  
A to Z... and Watch Service  
Troubles Disappear!



Read This  
**NEW GHIRARDI  
BOOK FOR 10  
DAYS at our risk!**



A. A. GHIRARDI

Here—just out—is the latest and greatest of the famous A. A. Ghirardi books, "RADIO AND TELEVISION RECEIVER CIRCUITRY AND OPERATION"! Actually, despite the many circuit variations, there are only a few really basic circuits in modern radio, FM and television receivers. Let this big, profusely illustrated book teach you all about these—and you'll be able to handle all types of service faster, better and lots more profitably!

**HANDLE TOUGH JOBS IN 1/2  
THE USUAL TIME!**

Starting with a clear explanation of AM and FM, RADIO AND TELEVISION RECEIVER CIRCUITRY AND OPERATION then progresses to a complete understanding of ALL basic circuits. You learn how each circuit operates—what it consists of—how to recognize it quick y—how to trace troubles with a minimum of laborious testing—how to make repairs promptly. By making it easy for you to understand each circuit and its relation to other circuits, this great book helps you go right to the seat of the trouble with far less time and effort. It speeds up your work. It makes it easy to understand new receivers—to know just how they function and how to service them quickly and accurately.

**NO OTHER BOOK LIKE IT!**

Prepare yourself for bigger jobs, better pay! Send coupon today. Read this great book for 10 full days under our MONEY-BACK GUARANTEE offer.

**10 DAY MONEY-BACK GUARANTEE**

Dept. RN-51, Rinehart Books, Inc.  
Technical Division, 232 Madison Ave.,  
New York 16, N. Y.

Enclosed find \$6 for A. A. Ghirardi's new RADIO AND TELEVISION RECEIVER CIRCUITRY AND OPERATION book or send C.O.D. and I will pay postman this amount plus postage. If book is not satisfactory, I will return it after 10 days and you guarantee to refund my \$6. (Price \$6.50 cash only outside U.S.A.—same return privilege.)

Name .....

Address .....

City, Zone, State .....

*Technical*  
**BOOKS**

"PRACTICAL RADIO AND ELECTRONICS COURSE" edited by M. N. Beitman. Published by *Supreme Publications*, Chicago. 330 pages. Price \$3.95.

This is the 1951 edition of a well-known text which is designed for the home study of radio and electronics. For the first time all of the lessons previously issued as three small volumes have now been included in a single binding. The material in volume one covers the fundamentals of radio and electronics. A unique method of presentation in this and the other two volumes allows the student to check his comprehension of the subject as he goes along by means of test questions and additional notes which parallel the text. The chapters covering "fundamentals" include a discussion of such subjects as radio components; symbols used in radio schematics; the mounting and wiring of parts; mathematics of radio; resistors and their use in radio circuits; battery testing; Ohm's Law and Kirchhoff's Laws as they pertain to radio; the properties of coils and transformers; condensers; L.C.R. and combined circuits; meters and their operation; vacuum tubes; power supplies; audio amplifiers and accessories; r.f. voltage amplifiers; and detection.

The second section covers various radio receiver circuits and typical examples; electronic oscillators; transmitter circuits and typical examples of such circuits; lines, antennas, and radiation; test equipment using meters; electronic test equipment; a.f.c.; FM; and the fundamentals of television.

The last section of the book is devoted to applied electronics and radio servicing. Included in this volume is data on various types of communications and industrial electronic equipment along with salient points on its construction and operation.

The text is clearly written, lavishly illustrated, and easy to understand. Persons unable to accept formal training in radio and electronics will find this home-study course a good introduction to the field and a springboard to more advanced study.

"OPPORTUNITIES IN TELEVISION" by Jo Ransom and Richard Pack. Published by *Vocational Guidance Manuals*, New York. 127 pages. Price \$1.00.

While most of the material in this little handbook is concerned with the studio and programming end of television, the book devotes one complete chapter to the job opportunities and technical requirements of installation, repair, and service technicians.

The authors have divided their book into eleven chapters, a bibliography, and several appendices. There are chapters on the over-all picture of television as a career, the requirements for actors, writers, directors, engineers,

**PREMAX**

**ANTENNAS FOR  
CIVIL DEFENSE**

Base and Center-Loaded Antennas to cover all amateur frequencies allocated for Civil Defense, plus spot channels used by MARS, CAP, National Guard, Etc. Straight whips for 28 to 50 meg. Plus all types of mobile mountings.

Fixed operations for HQ stations in ranges from 2 to 60 meg. can be had by using Premax Marine and Commercial Vertical Antennas up to 35 feet in height, and also Premax Coil-Loaded 17-foot models.

See your distributor or write for Catalog.



**PREMAX PRODUCTS**  
DIVISION CHISHOLM-RYDER CO., INC.  
5105 Highland Ave., Niagara Falls, New York

**PHOTOCON SALES**

Mail Order Address  
1060-2 N. Allen Ave.  
Pasadena 7, Calif.  
SYcamore 4-7156  
RYan 1-8271

Retail Sales Store  
1240 East Colorado St.  
Pasadena 1, Calif.  
5Ycamore 6-7217

**May Specials**  
WRITE FOR OUR LATEST  
**SURPLUS SALES CATALOGUE**

WE WILL BUY YOUR NEW OR CLEAN USED ELECTRONIC SURPLUS: ARC-1, ARC-3, BC-224, BC-348, BC-312, BC-312, ATC, ART-13, APS-13, BC-221, LM's, TS-12, TS-23, TS-34, TS-35, JE-19A, I-222, SCR-522, TS-100, I-100, or any BC, I, JE, TS, APR. WE NEED TUBES—30-4TL, 250HT, 810, 811, 813, 814, 815, etc. WE WILL BUY YOUR EXCESS NEW TUBES IN QUANTITY. PLEASE LIST EQUIPMENT, EXACT HONEST CONDITION, AND YOUR LOWEST PRICE.

BC-1060 Oscilloscope, 3 inch—Same as DuMont 22—LIKE NEW..... \$150.00  
DuMont 224 Oscilloscope, 3 inch—USED 125.00  
DuMont 208 Oscilloscope, 5 inch—EXCELLENT ..... 175.00  
BC-412 Oscilloscope—EXCELLENT ..... 60.00

**DIRECTION FINDER BUY OF THE YEAR**  
MN20E Loop for MN26 Compass, etc. —NEW ..... \$ 7.50  
MN52 Azimuth Control for MN26, etc. —NEW ..... 7.50  
MC124 Flexible Shaft for MN26, etc. —NEW ..... 3.95  
Combination Compass loop, Azimuth, Control, and flexible shaft, MN20E, MN52, and MC124 for making a compass of your present Receiver —NEW ..... 12.50

RME-15 with Speaker, 115V. AC, 550-KC-33MC—EXCELLENT ..... \$125.00  
National HRO, 115V. AC, 7 coils, 100-KC-30MC—EXCELLENT ..... 195.00  
BC-361 Target Receiver—5-channel control, sensitive relays, battery case, antenna, 68-73MC—NEW ..... 14.95  
APN-1 Altimeter Indicator O-1MA, 5MA, shunt, 250° dial—NEW ..... 1.95

One of the largest and most complete electronic surplus stocks in the country. We have thousands of tubes, capacitors, plugs, accessories, transmitters-receivers, test equipment, etc. Send us your requirements.  
TERMS: Prices C.O.B., Pasadena, California. 2 1/2% on all C.O.D. orders. Californians add 3 1/2% Sales Tax.

**RADIO & TELEVISION NEWS**

the job openings in the production end of telecasts, sales and promotion, research, in advertising agencies handling TV accounts, in programming, special events, news and announcing, and as technicians.

The bibliography includes a list of theater and film books in addition to a list of television, radio, and advertising periodicals. The appendices outline television courses of study, TV organizations, a job inventory, the operation of small TV stations, commercial TV stations now in operation, and a glossary of TV terms.

**"RADIO & TELEVISION ALMANAC"** by Orrin E. Dunlap, Jr. Published by Harper & Brothers, New York. 198 pages. Price \$4.00.

This text has been designed as a reference work for broadcasters, newspaper personnel, radio station staffs, and advertising agency personnel. It carries a chronological listing of landmarks in the radio and television field from 1844 to the present time.

In addition to recording such historical events as the first wireless contact, the first commercial broadcast, the first telecast, etc., the author has included data on important patents and inventions pertaining to electronics. A particularly valuable appendix lists members of the former Federal Radio Commission and its successor, the FCC; presidents of the IRE; presidents of the National Association of Broadcasters; presidents of the RMA; and presidents of the Television Broadcasters Association.

One interesting and historical section of the book includes over sixty photographs of "firsts" in the radio and television industry, pictures that record for posterity such events as the broadcasting of the Dempsey-Carpentier "Battle of the Century," the first broadcast made by a president of the United States, the first telecast of a president's speech, and the first successful wireless telephone contact.

Many of the day-to-day questions which arise in connection with television and radio are answered in this book.

**"WIRELESS SERVICING MANUAL"** by W. T. Cocking. Published by Iliffe & Sons, Ltd., London. 292 pages. Price 12s/6d. postage 5d.

This is the eighth edition of a text which is well known to both technicians and hams since it provides not only servicing data on radio receivers but also the answers to problems which often arise in the construction of amateur gear and in experimental work.

The text carries chapters on test equipment; current and voltage tests; the interpolation of meter readings; tubes; power line hum; motorboating; the causes and cure for instability in r.f. and i.f. stages; frequency and amplitude distortions; background noise and local interference; and tracking straight and superhet receivers. Troubleshooting for whistles and heterodyning; a.g.c. systems; short-wave receivers; short-wave converters; speak-

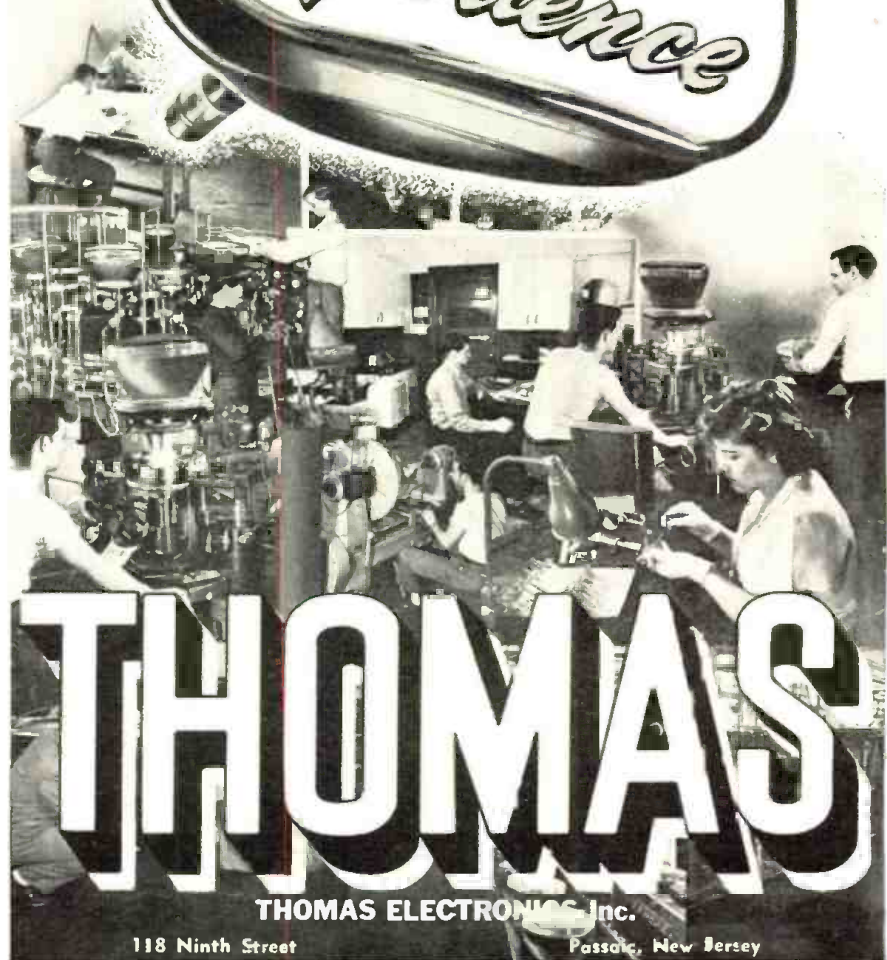

# THOMAS

THOMAS ELECTRONICS Inc.

118 Ninth Street

Passaic, New Jersey

## POWER!

Your ad in the Classified Section of **RADIO & TELEVISION NEWS** is read by the largest audience in the field—monthly circulation—over 200,000.

## EASY TO LEARN CODE

It is easy to learn or increase speed with an Instructograph Code Teacher. Affords the quickest and most practical method yet developed. For beginners or advanced students. Available tapes from beginner's alphabet to typical messages on all subjects. Speed range 5 to 40 WPM. Always ready—no QRM.



### ENDORSED BY THOUSANDS!

The Instructograph Code Teacher liberally takes the place of an operator-instructor and enables anyone to learn and master code without further assistance. Thousands of successful operators have "acquired the code" with the Instructograph System. Write today for convenient rental and purchase plans.

## INSTRUCTOGRAPH COMPANY

4711 SHERIDAN ROAD, CHICAGO 40, ILLINOIS

## YOUR SERVICE BUSINESS NEEDS!!

- TELEVISION SERVICE REPORT ..... \$3.93  
(Box of 100—3 copy business form)
- TELEVISION SERVICE PLAN ..... 2.25  
(Book of 100 TV service contracts)
- TELEVISION JOB TICKET ..... 1.60  
(Book of 100 TV job tickets)
- TELEVISION SERVICE CALL BOOK ..... .75  
(Salesbook of 50 triplicate sets)
- RADIO SERVICE RECORD ..... 1.50  
(Book of 100 Radio job tickets)
- RADIO WORK SHEET ..... .60  
(Pac of 50 repair sheets)
- RADIO SERVICE STANDARD RATE BOOK ..... 1.00
- TROUBLE TRACING IN AC-DC RADIOS ..... 1.00

See them at your **RADIO PARTS DISTRIBUTOR** or write for **Illustrated Catalog 2A**

## OELRICH PUBLICATIONS

4135 N. Lawler Ave. Chicago 41, Ill.

# SOMETHING NEW UNDER THE SUN

Who Says Prices Are Going Up?  
Now at Sun They're Lower Than Ever.

## Webster-Chicago Dictation MODEL WIRE RECORDER 18 Brand New—Discontinued Model

Includes microphone with stand, 1/4 hour cool wire, plastic dust cover, and removable foot switch.



### Dictation • Transcription • Playback

For Doctors, Dentists, Lawyers, Accountants, Secretaries, Clerks, Speakers, Businessmen, Hams, etc.

Includes the following exclusive Webster-Chicago features:

- Automatic Stops—shut off machine at end of wire
- Pushbutton record-listen switch
- Immediate playback thru 2 inch speaker
- Neon recording volume indicator
- Removable take-up drum
- Elapsed time indicator

**DRASTICALLY REDUCED FROM ORIGINAL PRICE OF \$135.00 TO AN ALL TIME LOW OF**

<b>RECORDING WIRE</b>	<b>ONLY \$89.50</b>
1 hour . . . \$3.50	Portable Carrying Case— Reg. \$12.50—Only \$8.95
1 1/2 hour . . . 2.10	
1 3/4 hour . . . 1.40	

### CRYSTALS FOR S.S.B. EXCITER

Also many other uses—in FT 241-A Holder—1/2" Pin SPC. Marked in 54th OR 72nd Harmonic MC Freq. Listed Below by Fundamental Frequency. Fractions Omitted. Lo Freq.

412	433	472	492	390	401	372	381	450	530
413	431	473	493	391	402	373	383	452	531
414	432	474	494	392	403	374	384	453	532
415	434	477	497	393	404	376	386	455	533
416	438	479	503	394	405	377	387	456	534
418	440	481	504	395	408	379	388		
419	441	483	506	396	409	380			
420	442	484	507	400	411				
422	443	485	509			<b>EACH</b>	<b>EACH</b>		
423	444	487	511			<b>39c</b>	<b>99c</b>		
424	446	488	516			<b>SPECIAL 200 KC XTALS</b>			
425	447	490	518			without Holders.			
426	448	491	519			21/23 x 23/32			
427	462			<b>EACH</b>		<b>79c</b>			
429	468			<b>49c</b>		<b>69c</b>	ea. 3 for	<b>\$2</b>	
431									

### HAM CRYSTALS

4190	6873	7840	3733	5850	6406	6705	7506
5030	6906	7873	5305	5873	6425	6740	7510
5185	6943	7906	5473	6873	6440	6803	7573
6006	7710	7973	5700	5900	6450	7306	7640
6040	773	8273	5740	5906	6473	7340	7673
6073	7806	8306	5750	5925	6475	7373	7706
6106			5760	5940	6506	7406	7804
6140			5773	5973	6540	7440	8340
6173			5775	5975	6573	7473	
6206			5806	6273	6406		
6173			5823	6340	6640	<b>99c EACH</b>	
			5840	6373	6673	<b>10 for \$9.00</b>	

### SCR-522 XTALS

5910	7180	2045	2220	2360	2587	3520
6370	7580	2105	2255	2390	2602	3550
6450	7810	2145	2290	2415	2615	3570
6470		2145	2292	2435	2637	3580
6470.9		2155	2300	2442	2650	3645
6522.8		2303	2332	2392	3655	
6547.9	<b>EACH \$1.29</b>	2320	2545	3510	3995	

### BC-610 XTALS

2 BANANA PLUGS—3/4" SPC.

Payments must accompany order. Enclose 20c for Postage & Handling. Crystal shipped packed in cloth bags. All Shipments Guaranteed.

**TERMS:** All items F. O. B., Washington, D. C. All orders \$30.00 or less, cash with order. Above \$30.00, 25 per cent with order, balance C. O. D. Foreign orders cash with orders, plus exchange rate.

# SUN RADIO

OF WASHINGTON, D. C.

938 F STREET, N. W. WASH. 4, D. C.

ers; antenna grounds; a.f.c.; push-pull amplifiers; negative feedback; miscellaneous circuit faults; the TV receiver; and the use of cathode-ray test equipment are also covered.

The appendix includes information on common circuit constants; standard symbols; formulas frequently required in radio work; antennas and feeders; copper wire tables; and circuits of some commonly-needed items of test equipment.

## Within the Industry (Continued from page 28)

tory in Long Island City to supplement its two existing plants in the area . . . **GLOBE-UNION, INC.** has added 65,000 additional square feet of manufacturing space for its **CENTRALAB** division at 424 North Fourth Street in Milwaukee . . . **NATIONAL ELECTRONIC MANUFACTURING CORPORATION** has moved to new and larger quarters at 4202 Vernon Boulevard, Long Island City, New York . . . The **CROSLY DIVISION** is expanding its plant in Richmond, Indiana, to provide an additional 211,200 square feet of manufacturing space. Construction of the new building is expected to be completed by October 1st of this year . . . Foundations have been completed for the new, 100,000 square foot radio and television center being erected by station **WCAU** on a 10-acre site outside of Philadelphia's business district. Completion is scheduled for the spring of 1952 . . . **SYLVANIA ELECTRIC PRODUCTS INC.** has purchased a new factory site at Woburn, Massachusetts. The factory, when completed, will be used for the production of electronic tubes and equipment for national defense . . . The Northwestern district headquarters and the Chicago sales office of the **WESTINGHOUSE ELECTRIC CORPORATION** have been moved to a new and permanent location on the second floor of The Merchandise Mart in Chicago. The new facility provides 45,000 square feet of space . . . **MOHAWK BUSINESS MACHINES CORPORATION** has recently moved its home office to 47 West Street, New York . . . **POTTER AND BRUMFIELD** is building a new and modern plant in Princeton, Indiana which will more than double the company's production capacity . . . The headquarters plant and engineering laboratories of the **WESTINGHOUSE ELECTRIC CORPORATION'S** new Electric Tube Division will be located on a 100 acre tract four miles northwest of Elmira, New York. Completion of the construction work is scheduled for early next fall . . . **TECHNOLOGY INSTRUMENT CORPORATION** has moved into its new plant in Acton, Massachusetts. The company was formerly located in Waltham . . . **SYLVANIA ELECTRIC PRODUCTS INC.** is building a new plant in Burlington, Iowa, for the manufacture of radio receiving tubes.

## WHY PAY MORE! Save on Surplus Buys

### OUTDOOR TRUMPET SPEAKERS

Heavy Duty, Blastproof! Made by Western Electric

Great for auditoriums, stadiums, theatres—sporting events, etc. Approx. 2 1/2 watt. Variable impedance 250, 500, 1000, 2500 ohms. Comes complete with adjustable pipe fitting to mount in any position. Excellent condition and a wonderful value at this low, low price. Order several!



Orig. Gov't Cost Approx. \$75 **\$9.95** Buy 4 for \$35.00

### BEAM MOTORS

With complete Operating Instructions for Use on 110 V. 60 Cycles



**\$3.95** Postpaid in U.S.A.

We've sold thousands of these powerful, highly geared motors for TV aerials and Ham Stations. Compare this price anywhere!

Final Closeout! 1000's Sold at \$9.95!

### JUST 50 MARK IX AIRCRAFT COMPASSES

Accurate instrument for planes, boats, autos, etc. Illuminated dial. Out they go at . . . **\$4.95**

WE PAY TOP \$ for all types aircraft, radio, test equipment. Need ARC-2's, ARC-3's, RA/ARN-7's, BC-348's, ART-13's, TS-34's. Send list, condition, asking price.

### ORDER DIRECT FROM THIS AD!

Prompt, speedy shipment. Cash with order. Minimum order \$3.00. 25% deposit on C.O.D. orders. Shipments by truck or RR express collect. California buyers please add state sales tax. All prices subject to change. Mdse. subject to prior sale.

**HUNDREDS OF ITEMS NOT LISTED. SEE OUR JAN., FEB. AND MARCH ADS FOR FULL DETAILS!**

## ALVARADIO SUPPLY CO.

Dept. A-13, 341 S. Vermont  
Los Angeles 5, Cal.  
Dunkirk 8-2211

## IMMEDIATE DELIVERY

# 300-OHM 7 STRAND TELEVISION LEAD-IN-WIRE

High quality, seven-strand, copper wire, covered with Pure Black Polyethylene . . . 55 mil. Immediate delivery. Quantity price on request. F. O. B. Baltimore. 20% deposit, Balance C. O. D.

# \$21.95

Per 1000-foot coil

**D & H Dist. Co., Inc.**  
25 S. Liberty St., Baltimore, Md.

## TELEVISION

### PREPARE FOR A GOOD JOB!

BROADCAST ENGINEER  
COMMERCIAL OPERATOR (CODE)  
RADIO SERVICEMAN

### Television Servicing

(Approved for Veterans)  
SEND FOR FREE LITERATURE

**BALTIMORE TECHNICAL INSTITUTE**  
1425 EUTAW PLACE, BALT. 17, MD.

## 4-CHANNEL E.C.O.

Channel 1 1050-1700 KC | Channel 3 3000-4800 KC  
Channel 2 2000-3400 KC | Channel 4 4370-7000 KC

Unit is the front end of the TA-121 aircraft transmitter add an 807 intermediate power amplifier and 2 807 for power amplifier you have a 50 watt transmitter, each channel is complete with 12SK7 tube is a complete oscillator with variable condensers, etc., each channel shielded all mounted on one chassis ready to add to kit.

**BRAND NEW ORIGINAL BENDIX PACK, \$9.95 EACH**

**McCONNELL'S**  
3834 Germantown Ave.  
Phila., Penna. RA 5-6033

**Quality Amplifier**  
(Continued from page 45)

for peaks with an oscillator and scope, and to make overload tests at about 20 cycles to look for bursts of high-frequency oscillation.

**Overload Stability**

Feedback amplifiers of this sort are susceptible to instability under overload conditions at low frequencies. This trouble is completely eliminated in the circuit described, but it always pops up when a new design is being worked out. What happens is that on low frequency overload peaks the output transformer core becomes momentarily saturated, its inductance drops way down and all its characteristics go to pot. On these peaks, then, the constants in the feedback loop momentarily go through a big change when the transformer is included in the loop, and oscillation is prone to result. In this type of circuit, then, it is necessary to use a good transformer to start with and to provide a large margin of stability against oscillation. Commonly this is done by connecting a condenser of .005  $\mu$ fd. or more across the output tube plates in order to drop the gain way down at the higher frequencies. This results in inadequate feedback at high frequencies and more distortion. In the present circuit, the condenser is left out, and the requisite stability obtained by careful over-all design.

**Phase Inverters**

Another source of instability at or near overload is the phase inverter. In the usual circuits, the phase inverter tube gets its grid signal from an amplifier tube which is itself driving one side of the output stage. When the output stage begins to draw grid current, not only does the excitation drop off, but the phase inverter loses its grid excitation too. This causes the input to the output stage to become lopsided, leading to premature saturation of the output transformer and general instability.

With the split-load phase inverter both sides overload symmetrically and

Under chassis view of TV sound amplifier.

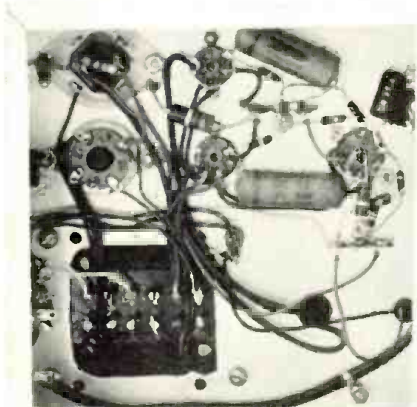

**BB-36**  
... for all channels ...

... BROAD BAND ANTENNA ...  
A single element!

**Bazuka**  
Patent Pending

*The King of all Antennas*

The new Bazuka antennas with their simple compact designs ... eliminate cluttered skylines ... this quick-rig method makes installations a matter of seconds — regardless of weather or location.

.....  
Visit our display booth in the "Radio Parts Show" Booth 101 May 20-23 in Chicago.  
Please write for brochure "B"

**VERI-BEST ELECTRONICS CO.**  
233 Spring Street • New York 18, N. Y.

**TV CHASSIS SPECIAL!**

New Improved De Luxe 630 Chassis manufactured under R.C.A. patent, complete with 30 tubes. NOT A KIT, but a factory wired, engineered, tested, and aligned TV Chassis. Just Plug it in and it works.

**IMPORTANT FEATURES:**

- Newly developed keyed automatic gain control
- Improved Automatic frequency control (Syncrolock)
- Voltage doubler produces 16KV for maximum brilliance
- Wide angle deflection yoke will spread any 14", 16", 17", 19" or 20" picture tube
- Large cartwheel focus coil for razor sharp focusing
- Moulded plastic condensers
- 12" R.C.A. Speaker

Perfect Chassis for any size and shape picture tube—complete with knobs, escutcheon plate and hardware.

- |                                  |         |   |
|----------------------------------|---------|---|
| 16" Glare Proof Tube (Rect.) ... | \$39.50 | <p><b>\$146.50</b><br/>(Less CRT)<br/>Includes All Fed. Taxes</p> <p>(Includes All Federal Taxes)</p> |
| 17" Glare Proof Tube (Rect.) ... | 41.50   |   |
| 19" Glare Proof Tube (Round) ... | 64.50   |   |
| 20" Glare Proof Tube (Rect.) ... | 68.50   |   |

Standard RMA Warranty

Terms: 25% Deposit with Order—Balance C.O.D., F.O.B. Brooklyn, N. Y.  
**J & H TELEVISION CO.**

Price and Models subject to change without notice!

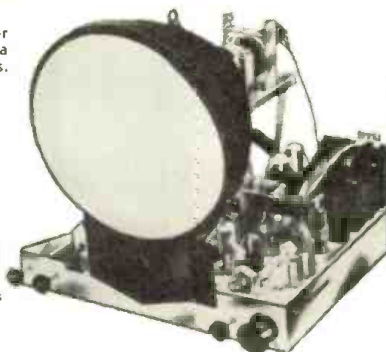

# ANNOUNCING!

## THE NEW MODEL 706A **RCP**

### "WIDE RANGE" SIGNAL GENERATOR

FOR  
**BETTER OVERALL PERFORMANCE**



MODEL 706A

SIGNAL GENERATOR . . . . \$67<sup>50</sup>  
NET

RCP now makes available to you this brand new, precision packed "wide range" SIGNAL GENERATOR for better overall performance in your Service testing. New all exclusive features including continuously variable modulation from 0% to 80%. Excellent for FM alignments. Highly satisfactory performance with sharp, easy reading calibrated dial, eight scales from 150KC to 220 MC. Planetary drive. Marker calibration—accurate to within 1%. Thorough shielding of all critical circuits and components, including oscillator tube, coil assembly, attenuator, switching circuit. Output—high and low level. Ladder type step Attenuator. Tube Complement: 6BA6, 6SJ7, 6X4.

A high quality instrument in performance, construction and appearance—the new Model 706A is handsomely finished in Grey and White Hommertone case. Comes complete with tubes and accessories ready to operate on 105-130 Volts 60 Cycles. Size: 15"x9"x7". Weight 14 lbs.

Buy from your Jobber  
Insist on RCP Instruments  
Write for Catalog RN-5

**RADIO CITY PRODUCTS CO., INC.**  
152 West 25th Street,  New York 1, N. Y.

Triode Characteristics	(6V6 or 6AQ5)
Amplification Factor	9
Plate Resistance	2400 ohms
Mutual Conductance	3800 micromhos

As single-tube class A <sub>1</sub> Power Amplifier	
Plate Voltage	300 v.
Grid Bias	-20 v.
Plate Current	30 ma.
Load Resistance	8000 ohms
Power Output	1.5 w.

As push-pull class A <sub>1</sub> Amplifier	
Plate voltage	300 v.
Grid Bias	-25 v.
Plate Current	50 ma. (2 tubes)
Cathode Resistor	470 ohms
Load Resistance	12,000 ohms (p. to p.)
Power Output	4.5 w.

Table 1. Characteristics of 6V6 or 6AQ5.

the general behavior at and near the overload region is a lot smoother. Both the straight conventional inverter and the "floating paraphase" modification of it were thoroughly tested in this amplifier, and discarded in favor of the one shown. The split-load inverter does have the disadvantage of lower maximum voltage output, but in this application the voltage swing capability of both the voltage amplifier and the inverter stages are adequate, as indicated by the curve of Fig. 2.

This amplifier is completely stable both under load and on open circuit, at all signal levels including extreme overload, at all frequencies.

It is advisable not to add any unnecessary stray capacitance to ground across the plate circuit of the first stage V<sub>1</sub>.

#### D.C. Coupling

The d.c. operating point of the phase inverter needs some attention. For lowest distortion the voltage drop across R<sub>a</sub> and R<sub>r</sub> should total about

70 volts each. This places the cathode of this triode about 70 volts above ground. To avoid straining the cathode-heater insulation it is inadvisable to operate the cathode above about plus 90. This is the reason for the unusually high plate load resistor on the first stage—to make the d.c. plate potential low enough. Condenser coupling was tried between these stages and found to give no advantage.

When the power is first turned on, the plate supply voltage appears before the tubes' cathodes are warmed up. This allows the phase inverter tube grid, and hence its cathode, to rise almost to the "B" supply potential for a few seconds. To prevent damage to the heater-cathode insulation by this transient potential, a 2.2 megohm resistor, R<sub>s</sub>, is connected from the grid of the phase inverter to ground. During warmup, this resistor acts as half of a divider in conjunction with the plate load R<sub>p</sub>, and limits the cathode potential to about 150 volts.

If a slow-heating rectifier tube is used, such as the 5V4G or 6AX5, resistor R<sub>s</sub> can be omitted. Its shunting effect on the audio output of V<sub>1</sub> is small, however, since the plate impedance of the 12AX7 as used here is around 200,000 ohms.

#### Power Supply

Except for the rather small amount of filtering used, the power supply is entirely conventional. While the writer is not one to skimp on using chokes, it was found that in this case the filter shown was completely adequate.

The power transformer shown in the photograph is a surplus unit that happened to be on hand. Any transformer supplying 300 volts each side of center-tap at 50 milliamperes or more is satisfactory.

The Western Union Telegraph Company recently introduced a new facsimile unit—the "High-Speed Fax." Capable of transmitting or receiving any written, printed, or picture matter at high speed over any distance, the copy requires no advance preparation or processing whatsoever. Transmission and recording, in finished form, is at the rate of 3000 words of newsprint a minute or 180,000 words an hour. The capacity of the new system is so great that a 90-page issue of a magazine could be flashed by facsimile to any distant point in one hour. The received material is printed on a new electro-sensitive dry recording paper, tradenamed "Teledelto."





## International Short-Wave

(Continued from page 118)

sent with the transmitter were not of correct value for the 25-m. tank and new ones were on order via airmail from California. (Boice, Conn.) *Watch for TGNA on 11.85 around 2200-2230.* Other channels are 6.039, 9.668 (still announced 6.040, 9.660, says Kroll, N. Y.). The station often interviews missionaries in Guatemala and other Central American countries—usually after (normal) 2230 closedown. The Mailbag Program at 2230-2245 on Wednesdays sometimes runs as late as 2300, according to Sklenar, Cuba (formerly of Nebraska), and others.

TGTQ, *Radio Internacional*, noted on 6.285 at 0115-0200. (Machwart, Michigan). A Guatemalan station was heard recently on about 6.33 with marimba music at 1843; fair level; may be TGTA, listed 6.335? (Bellington, N. Y.)

Haiti—4VEH, Cap Haitien, noted leaving the air 1830 on 9.745 and announcing return at 2200 on 9.730. (Hoffman, N. Y.) *Radio Sweden* says this one has moved from 9.885 to approximately 9.745; opens 0700; uses 9.745 "mornings" and 9.730 "evenings;" a verification card is being printed; that 4VRW, Port-au-Prince, is back on 9.840, opens 0650. Oskay, N. J., recently measured 4VEH as 9.746V at 0745; and as 9.728 at 1840.

Hong Kong—ZBW3, 9.5242, meas-

ured recently at 0710, when had Chinese musical program; some QRM to 0730, very good signal after that time. (Oskay, N. J.) Should take a BBC news relay around 0600.

India—AIR noted signing on in *English* at 1000 on 15.290, announced as operating in the 19- and 31-m. bands; heard signing on in *English* at 1400 on 7.155 and 9.270, news to 1410, then music to 1500. Noted with *English* for Southeast Asia on 17.84 at 0830, announced 15.350 as parallel; 1030 news heard on 6.010. Madras, 4.920, noted 1045 with AIR news relay. (Pearce, England). This one is fair level in West Virginia with news 0730.

Indo-China—*Radio France-Asie*, Saigon, noted on 11.780 signing off 1000 with *English* identification and "La Marseillaise." (Russell, Calif.) This one has news 0900. Is heard by Hutchins. *Radio Australia*, on 9.524, after 0500.

Latest available schedules from *Radio France-Asie* include *English* at 1700-1800 and 1945-2000 on 9.524; at 0500-0515 on 11.830; 0900-0915 on 11.780; *English* period for Australia-New Zealand 0420-0500 on 11.830 and for Southeast Asia 1930-1945 on 9.524; lists entertainment in French daily 0800-1015 on 9.524 and "bilingual" entertainment daily same time on 11.780; lists French at 1715-1730 on 9.524, 1815-1845 on 9.524, 6.116, 1915-1930 on 9.524, 6.116, 2115-2130 on 11.780, 2345-0000 and 0700-0735 on 9.524, 1015-1030 on 11.780, 9.524; lists Mandarin (Chi-

# AMPERITE

## Studio Microphones at P.A. Prices



**Ideal for BROADCASTING RECORDING PUBLIC ADDRESS**

"The ultimate in microphone quality," says Evan Rushing, sound engineer of the Hotel New Yorker.

- Shout right into the new Amperite Microphone—or stand 2 feet away—reproduction is always perfect.
- Not affected by any climatic conditions.
- Guaranteed to withstand severe "knocking around."

Models  
RBLG—200 ohms  
RBHG—Hi-imp.  
List \$42.00

'Kontak' Mikes  
Model SKH, list \$12.00  
Model KKH, list \$18.00

**Special Offer:** Write for Special Introductory Offer, and 4-page illustrated folder

**AMPERITE Company, Inc.**  
561 BROADWAY • NEW YORK 12, N. Y.  
Canada: Atlas Radio Corp., Ltd., 560 King St. W., Toronto

# Learn... RADIO • TELEVISION • ELECTRONICS

## Practice at Home in Your Spare Time

**PRACTICAL EXPERIENCE AND TECHNICAL TRAINING LEAD TO BIG PAY JOBS!**

### PRACTICE—LEARN

#### YOU BUILD

this modern 3-stage transmitter in one fascinating section of Central training.



#### YOU'LL LEARN

all phases of television theory, servicing... receivers and transmitters.

#### YOU MAKE

this Multi-Tester for checking tubes and circuits. Worth \$40 or \$50.



### PLUS...

DC continuity tester — Power supply unit — Simple radio receiver — Three tube and rectifier receiver — Five tube and rectifier super-heterodyne radio receiver.

### STEP AHEAD WITH CENTRAL TRAINING

Central graduates are employed the world over. Some TV stations are operated exclusively by Central graduates. There are more openings than there are trained men. *Free Placement.* Be a—

- Broadcast Engineer (AM-FM-TV)
- Manufacturing Technician
- Radio-Television Serviceman
- Emergency Radio Operator
- Airlines Radio Operator
- Public Address Serviceman.

All essential jobs in a *New, Rich* field of *Opportunity.* Plan your professional career now, by sending for *Free Literature.*

### FCC First Class License

issued by the Federal Communications Commission of the United States Government. The good jobs and great opportunities go to the men who hold the 1st Class License. Let Central help you get this "Ticket" to Success!

### An Exceptional School

Central Radio & TV Schools, Inc., is a member of the National Home Study Council, 2601 Sixteenth St., N. W., Washington, D. C. ... founder members Missouri Assoc. of Private Schools, 1644 Wyandotte, Kansas City 8, Missouri ... Kansas City Chamber of Commerce ... professional Members of the National Rehabilitation Assoc., 1025 Vermont Ave., Washington 5, D. C. (We invite you to investigate us thru any of these organizations or thru our graduates.)



Central graduate R. J. Anderson, Television Engineering Supervisor, WDSU-TV, New Orleans, La.

Central Graduate Quentin Cuthbert, Ground Radio Operator, Eastern Airlines, Washington, D. C.



### RECENT SURVEY SHOWS

Radio-TV employees earn average annual income of \$4,469. Second highest of all industries rated by U. S. Dept. of Commerce.

### FREE BOOK

**MAIL COUPON TODAY!**



CENTRAL RADIO and TELEVISION SCHOOLS, Inc. Dept. E-5, 1644 Wyandotte, Kansas City, Mo.

I want complete information on how I can succeed in Radio, Television and Electronics. This does not obligate me in any way.

Name.....  
Address..... Age.....  
City..... Zone..... State.....

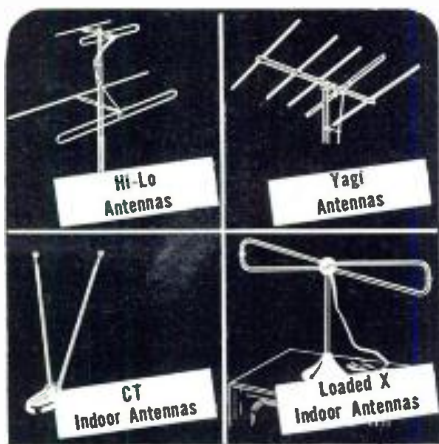

# 8 Good Reasons for you to CHOOSE CORNELL-DUBILIER Skyhawk TV ANTENNAS

One of the reasons for the splendid acceptance of C-D SKYHAWK antennas is the completeness of the line. Whatever the application... whatever the situation... THERE IS A CORRECT C-D ANTENNA FOR EVERY NEED. No need to accept inferior makes or substitute types when the C-D antenna line offers a full variety... each doing a specific job... BETTER!

**CORNELL-DUBILIER ELECTRIC CORP.**  
SOUTH PLAINFIELD, NEW JERSEY

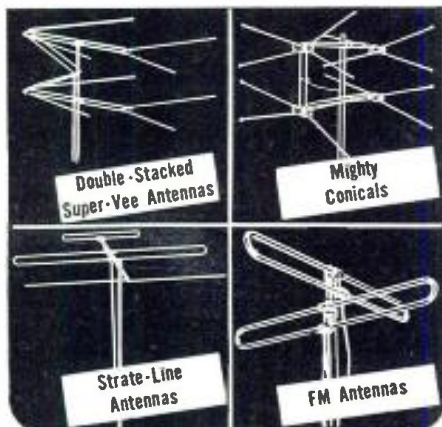

154

nese) 1345-1900, 2245-2300, 0400-0415 on 9.524, and Cantonese (Chinese) at 2245-2300, 0415-0430, and 0745-0800 on 6.116. (Wadhams, Calif.)

**Indonesia**—YDC, 15.15, Djakarta, noted 1000-1030; news 1015. (Sutton, Ohio) Heard on this channel closing *English* period at 1028 and announcing channels in use as 15.150 and 4.910; mentioned three daily *English* broadcasts—0600, 0900, 0930, and said at 1030 would continue in Hindustani. Noted on 15.15 signing on 0930 with home and world news; "Open Letter" at 0945. (Pearce, England) YDF, 6.045, noted 1830 announcing as *Radio Nacional*. (Grischott, Calif.)

**Iraq**—The Iraq Broadcasting Station, Baghdad, sent a QSL card recently verifying reception of January 3, 1949, on 7.092; said *new* transmitter is *Marconi* type S.W.E. 10 s.w., 16 kw. to antenna in operation March 1951; class B modulation; antenna omni-directional; schedule is 2330-0100, 0430-0600, 0830-1500; Arabic and occasional European music and talks; interval is bird call; time signal is clock striking; said, "Many regrets for delay; please report on new transmitter later." (Pearce, England) Has a new verification card. (Radio Sweden) *ISWC*, London, lists YI5KG, 7.092, at 1000-1700. At times may use 7.062.

**Israel**—4X4EA, 6.725, Israeli Forces Station, noted signing on with bugle call and identification by woman at 1130; played varied records, interspersed with talks; noted another day signing off 1500 with bugle sounding "Lights Out;" *no English heard*.

According to announcement, Tel Aviv, 9.0108, is now the only short-wave outlet carrying the "Voice of Zion" (*English*) relay from Jerusalem at 1700-1745 daily; that period is no longer relayed by Jerusalem 6.830. The news is 1515 over both Tel Aviv, 9.0108, and Jerusalem, 6.830, and *English* is also announced for 0700 on 6.830. A more recent measurement of Tel Aviv's HXB21 (announced 9.000) was 9.0125V, according to Oskay, N. J.

**Italy**—Rome noted with *English* 1415-1500 on 9.575, 11.905. (Pearce, England) Has been heard on 9.671 signing off 2200 with good level, and announcing program as at 1900-2200. (Ferguson, N. C.) I have heard this one parallel with 9.575 at the time mentioned by Ferguson.—KRB. Has news 2145-2200.

Noted on 6.010 with news 1900-1915, bad QRM. (Lane, South Dakota) Heard opening in foreign language 1030 on 15.120, 15.313. (Grove, Ill.)

**Jamaica**—McWalter, Scotland, received this interesting data from *Radio Jamaica*—"Our short-wave transmitter is operated on a vertical radiation pattern and is intended only to give good reception throughout the island of Jamaica. However, when weather conditions are favorable for skips, we are occasionally heard in other parts of the world. You may be interested to know that we use a standard broadcast transmitter on 880 kc. to cover the metropolitan area of Kingston, but

## RED ARROW FOR BETTER BARGAINS SPECIAL! 300 OHM TWIN LEAD TV LINE. \$3.89 per hundred ft. (\$3 per thousand ft.)

### FILTER UNIT

This unit is an excellent buy for parts alone. Some parts are worth more than we're asking for the whole unit.  
1—40 MFD @ 450V; 1—1000 MFD @ 12V; 1—.5 MFD @ 400V; 2—.5 MFD @ 50V; 1—.01 MFD @ 400V; 2—20 watt Resistors; 2—Filter Chokes; 3—RF Chokes; 1—DPST Toggle Switch; Miscellaneous hardware, wire, etc.  
Brand New, Original Packing. . . . .89c ea.  
(10 for \$7.50)

### TUBE SALE—Brand New

VT25A 10Y . . . . .39c 162B . . . . .39c  
3C24 24G . . . . .59c 5T1 . . . . .\$1.59

### DYNAMOTORS

PE 73—excellent, used F BC 375 . . . . .\$4.95  
PE 94—excellent, used F SCH 322 . . . . .4.95  
PE 208 Inverter, used, good. . . . . 8.95  
DM 33A—brand New . . . . . 4.95  
Power Unit 108A with Ballentine  
Dynamotor, Brand New, Original Packing. . . . .33.95

### BC 783-B AMPLIFIER

Brand New—Original Packing—Made by G.E. Contains the following parts, mounted on a chassis 2" high, 2 1/2" wide, 8" long.

1—Metal R.C.A. 6L6 Tube	1—10,000 ohm 20 w. w.w. resistor
1—4 MFD .600 VDC Pyranol.	5—Resistors, 1 & 2 w.
1—1 .800 VDC Bathub.	4—Mica Condensers.
1—.5 .600 VDC Bathub.	1—Phone Jack
1—8,000 ohm 20 w. w.w. resistor.	1—Ceramicon Socket.
	2—Terminal Strips.

EACH **\$6.95**

### TERRIFIC KIT SALE

Kit of 50 Assorted KNOBS. . . . . \$1.19  
Kit of 100 Assorted PAPER TUBULAR CONDENSERS, 200 to 800 V. . . . . 5.75  
Kit of 10 Assorted VOLUME CONTROLS. . . . . 2.75  
Kit of 100 MICA CONDENSERS . . . . . 4.95  
Kit of 50 TRIMMERS . . . . . 1.98  
Kit of 100 CERAMICON CONDENSERS. . . . . 4.95

MINIMUM ORDER—\$2.00. Send 25¢ deposit with order, balance C.O.D. Shipped F.O.B., N.Y.C. (N.Y.C. residents add 2% sales tax.)

### RED ARROW SALES CO.

Dept. A, 63 East Broadway, N. Y. 2, N. Y.  
Phone—COrtlandt 7-5425

## WANTED

### "S O" TYPE RADAR PARTS

Write or Phone

World Wide Packing & Shipping Co.  
350 Pearl St. Brooklyn, N. Y.  
MAin 4-8371

## \$50,000 IN SPOT CASH

### Available for SURPLUS Radio & Electronics Equipment

We want large or small quantities and we'll pay HIGHEST spot cash prices.

Write, wire or telephone details to  
NEWARK SURPLUS, Market 3-7472  
324 Plane St. Newark 1, New Jersey

### TWIN-TRAX\* TAPE RECORDERS

designed... **ENGINEER** in mind  
with the

### A COMPLETE SERIES

... of high fidelity, dependable tape recorder—from transport mechanisms to highly specialized instruments, including the one YOU want. Write today for catalog 5101. Includes ALL technical specifications and direct factory prices.

**AMPLIFIER CORP. of AMERICA**  
398-10 Broadway New York 13, N. Y.

\*Trademark Reg.

RADIO & TELEVISION NEWS

owing to the mountainous terrain of this island, a short-wave transmitter also is necessary for complete island-wide coverage."

The 3.360 outlet recently seems to have extended program to 2310 so it can take the BBC news relay at 2300. (Bellington, N. Y., others) Closes with "God Save the King."

**Japan**—AFRS, 11.80, Tokyo, noted with popular American recordings 0245-0300 sign-off. (Bellington, N. Y.) The AFRS outlet on 4.860 heard with news 0400; JKL, 4.940, heard with NHK program 0800-0830; only English is call-letters "N.H.K." (Callarman, Oregon) NHK program noted on 9.695 at 1740, light musical selections, announcements by man in Japanese, call at 1759, followed by time pips; heard on 9.655 at 1725 with talk in Japanese by man, and time pips noted at 1800. (Pearce, England)

**BCOF** (British Commonwealth Occupation Forces), 6.105, Kure, is scheduled 1630-0830 (Saturday to 0900). (Radio Australia)

**Kenya**—VGQI, 4.855, Nairobi, is being heard in the United Kingdom at 1300 with news, then recordings; closes 1400 and announces will return at 0600. (ISWC, London)

**Lebanon**—Beirut, 8.036, noted 1530 with news in Arabic; signed off 1600 with march recording. (Pearce, England) Heard recently 0005-0015 with native news, then music to 0030; good level in Ohio. (Sutton)

**Madagascar**—FIQA, 9.515, Tananarive, noted with music 1050, announcements in French. (Russell, Calif.) Heard here in West Virginia signing on with interval signal and "La Marseillaise" at 2230, using French; noted then by Ferguson, N. C., and with news in French 2311-2325.

The 7.38 channel normally carries Malgache or Comorian programs but may have French on occasion. (Ridgeway, South Africa)

**Malaya**—Radio Malaya, 7.25 and 7.200, has not been heard lately; the 6.135 outlet carries native programs mornings. BFEBS, Singapore, is back on its proper channel of 11.880. (Balbi, Calif.) Is heard fairly well early mornings, around 0700-0830, here in West Virginia. BFEBS, 15.300, noted by Lane, South Dakota, fair at 1100 and signing off at 1130.

**Malta**—Pearce, England, and Bellington, N. Y., report that when FBS, Middle East, closes at 1600 on 7.220 it announces frequencies of 15.125, 7.220, 6.015, 3.305; Pearce says when it closes 0200 on 7.220 it announces return at 0530 on 15.125, 7.220, 3.305.

**Martinique**—Fort-de-France, 9.700, can be heard after 1730 when a USA station leaves that channel. (Stark, Texas, others) Noted with news in French 1834, and signing off 1839 (did not play "La Marseillaise"). (Arthur, W. Va.) Is heard in Britain. (Pearce)

**Mauritius**—V3USE, 15.050A, noted in French 1159 and signing off 1230 with "God Save the King;" no English noted. (Pearce, England) Is heard in South Africa at 1000. (Ridgeway)

# TERRIFIC VALUES! TUBES

STANDARD BRANDS ONLY  
FULLY GUARANTEED

024A	\$1.09	3Q5GT	\$1.13	6BE6	\$1.65	6S4	\$1.15	7C7	\$ .93	12SF7	\$1.01
1A3	1.05	3S4	.98	6BG6G	2.23	6S8GT	2.00	7E5	1.25	12SH7	1.09
1A6	1.69	3V4	.98	6BH6	1.90	6SA7	1.40	7E6	1.09	12SJ7	.91
1A7GT	1.04	5R4GY	1.49	6BJ6	1.90	6SA7GT	1.40	7E7	1.09	12SJ7GT	.89
1B3GT	1.77	5T4	1.70	6BQ6GT	2.95	6SB7Y	1.20	7F7	1.04	12SK7	1.66
1B5	.95	5U4G	1.25	6C4	1.10	6SC7	1.40	7F8	2.35	12SL7GT	1.06
1C6	.85	5V4G	2.10	6C5	.81	6SD7GT	1.27	7G7	1.29	12SN7GT	2.00
1C7G	.95	5W4	.81	6CB6	1.60	6SF5	.91	7H7	1.89	12Z3	.97
1D7G	.95	5X4G	.89	6CD6G	3.75	6SF7	.97	7J7	1.31	14A7	1.05
1F4	.75	5Y3GT	1.17	6C6	.87	6SG7	1.80	7K7	1.31	14B7	1.05
1F5G	.95	5Z3	.97	6C8G	.97	6SH7	1.24	7L7	1.31	14E7	1.05
1G4GT	.97	5Z4	1.17	6D6	.87	6SH7GT	1.29	7N7	2.20	14Q7	1.05
1G6GT	1.17	6A3	1.37	6D7G	.87	6SJ7	1.59	7Q7	.94	14R7	1.27
1J6G	.95	6A4	1.59	6E5	1.09	6SJ7GT	1.59	7R7	1.13	25L6GT	1.00
1L4	.95	6A6	1.31	6F5	.81	6SK7	1.19	7S7	1.31	25Z6GT	1.25
1LA6	1.30	6A7	1.04	6G6	1.03	6SK7GT	1.19	7T7	1.01	30	.88
1LC5	1.30	6A8GT	1.04	6F6G	1.03	6SL7GT	1.19	7V7	1.31	32L7GT	1.67
1LC6	1.30	6A87	1.39	6F7	1.37	6SN7GT	1.75	7W7	2.40	35Y4	.89
1LD5	1.30	6A7	1.70	6F8G	1.47	6SQ7GT	1.25	7Y4	.89	35Z5GT	1.45
1LN5	1.30	6AF6G	1.31	6G6G	.97	6SR7	1.50	7Z4	.93	50A5	1.33
1NSGT	.97	6AG5	1.90	6H6	1.13	6SS7	.89	12A6	.97	50B5	1.60
1PSGT	.97	6AG7	2.87	6J5	.79	6T8	2.70	12A8GT	.99	50C5	1.02
1Q5GT	.97	6AH6	3.45	6J5GT	.80	6U5	1.10	12AL5	1.80	50L6GT	1.60
1R5	1.05	6AK5	2.75	6J6	2.90	6U7G	.89	12AT6	1.40	55	.83
1S4	1.19	6AL5	1.50	6J7	1.70	6V6GT	1.19	12A7	2.65	57	.83
1S5	.97	6AQ5	1.45	6J7GT	1.70	6W4GT	1.40	12AU6	1.85	77	.89
1T4	1.04	6AR5	1.40	6J8G	1.39	6W6GT	1.60	12AU7	2.20	2051	.89
1T5GT	1.30	6AS5	1.85	6K6GT	.80	6X5GT	1.00	12AV6	1.35	28D7	1.33
1U4	.97	6AS7G	6.50	6K7	.75	6Y6G	1.19	12AV7	3.00	VR105	1.49
1U5	.94	6AT6	1.30	6K7GT	.79	7A4	.97	12AX7	2.40	VR150	1.65
1V	.97	6AU5GT	1.75	6K8	1.04	7A5	1.09	12BA6	1.45	304TL	22.60
1X2, 1X2A	1.77	6AU6	1.60	6K8GT	1.04	7A6	.89	12BA7	2.00	307A	9.95
2A3	1.27	6AV5GT	1.85	6L5G	.97	7A7	1.59	12BE6	1.55	703A	3.95
2A5	.88	6AV6	1.30	6L6	2.25	7A8	.89	12BH7	2.00	705A	2.55
2A6	.88	6AX5GT	1.45	6L6G	1.97	7B4	1.39	12C8	1.34	707B	14.95
2A7	.88	6B4G	1.89	6L7	.97	7B5	1.49	12F5	.89	803	5.95
2C44	1.49	6B7	1.35	6L7G	.97	7B6	1.49	12H6	1.65	805	4.95
2E22	1.37	6B8G	1.37	6N7	1.40	7B7	.89	12J7GT	.99	807	1.85
2X2/879	1.31	6BA6	1.60	6N7GT	1.25	7B8	.89	12Q7GT	.89	813	8.95
3A5	1.25	6BA7	1.20	6P5GT	1.23	7C4	.89	12SA7	1.03	913	8.95
3D6/1299	.68	6BC5	1.90	6Q7	.87	7C5	.88	12SF5	.77	900A	.56
3Q4	.97	6BD6	1.90	6R7	.97	7C6	1.59	12SF5GT	.78	9006	.55

## WIRE WOUND RESISTORS

	5 WATT		10 WATT	
	Price or more each	10 or more each	Price or more each	10 or more each
75 Ohms	\$0.21	\$0.19	.15	.16
100 Ohms	.21	.19	.15	.16
200 Ohms	.21	.19	.15	.16
5,000 Ohms	.22	.20	.16	.16
6,000 Ohms	.22	.20	.16	.16
10,000 Ohms	.22	.20	.16	.16
10 WATT				
1.5 Ohms	.21	.19	.15	.15
18 Ohms	.21	.19	.15	.15
23 Ohms	.21	.19	.15	.15
100 Ohms	.22	.20	.16	.16
300 Ohms	.23	.21	.17	.17
450 Ohms	.23	.21	.17	.17
10,000 Ohms	.24	.22	.18	.18
20,000 Ohms	.24	.22	.18	.18

## EXTRA SPECIAL ALL AMERICAN TUBE KIT

12SA7, 12SK7, 12SQ7, 50L6GT, 35Z5GT.....\$4.95

## RESISTOR KIT

100 popular values.....\$3.49

## TV HV "Cartwheel" CONDENSERS

500 mmfd. 10 KV.....\$0.49  
500 mmfd. 15 KV......59  
500 mmfd. 20 KV......69

## PM SPEAKERS ALNICO No. 5

Very Best Quality. NATIONAL BRANDS. Individually Packed.



	Price each	10 or more each
4"	\$1.75	\$1.69
5"	1.89	1.79
8"	3.59	3.25
10"	5.49	5.25
12"	6.89	6.49

## MICA CONDENSER KIT

100 most popular values.....\$7.35  
30 assorted values.....2.50

Minimum order \$3.00. 25% deposit on C.O.D. orders. Prices subject to change without notice. Availability of merchandise subject to prior sale.

## STEVE-EL ELECTRONICS CORP.

Dept. R-5 65 READE STREET NEW YORK 7, N. Y. Cortlandt 7-0086

Speakers Need Repairing?



## Recone with a WALDOM CONE

Speakers are hard to obtain. Recone with Waldom cones.

Send for your FREE WALDOM Replacement Cone Manual Catalog!

FREE, 24-page manual is yours without obligation. Data on over 750 TV, FM, AM speakers. WRITE TODAY!

- WALDOM CONES
  - \*\*\* maximum efficiency,
  - R.M.A. warranty, true low frequency response, unconditionally guaranteed.

WALDOM ELECTRONICS, INC. 911 N. Larrabee St., Chicago 10, Ill.



Cuzco, 0700-2400; OAX1A, 6.150, 0.25 kw. (Delcar), Chiclayo, 0700-2400; OBX4B, 6.170, 0.35 kw. (Azul), Cerro de Pasco, 0700-2400; OAX4G, 6.190, 0.25 kw. (Lima), Lima, 0700-2400; OAX1B, 6.198, 0.30 kw. (Piura), Piura, 0700-2400; OAX4P, 6.200, 0.25 kw. (Huancayo), Huancayo, 0700-2400; OAX6H, 9.500, 0.10 kw. (Tacna), Tacna, 0700-2400; OAX4W, 9.510, 0.50 kw. (America), Lima, 0700-0400; OAX4J, 9.520, 0.25 kw. (Colonial), Lima, 0700-0130; OAX4K, 9.545, 0.30 kw. (Central), Lima, 0700-0130; OAX4R, 9.562, 10 kw. (Nacional), Lima, 0700-2400; OAX5C, 9.590, 0.20 kw. (Universal), Ica, 0700-2400; OAX4T, 15.150, 10 kw. (Nacional), Lima, 0700-2400.

**Philippines**—Far East Broadcasting Co., Manila, is again testing on 9.730; noted around 0430-0530 or later; measured by Hutchins, *Radio Australia*, as 9.734. Grischott, Calif., reports DZH7, 9.730, and DZH8, 15.300, ending *English* program at 0530; continued in Burmese with Protestant hymns; announced in *English* at 0600.

DZH4, 6.000, Manila Broadcasting Co., signs off 1100; network cue is "From A to Z, it's MBC, the Manila Broadcasting Co.," mentions DZMB, 760 kc., 1 kw.; DZH4, 6.000, 1 kw., and DZH2, 9.640, 1 kw. (Callarman, Oregon)

**Poland**—Radio Warsaw sent schedules by air to Pearce, England, listing *English* for 1200-1230 on 9.570; 1245-1315 on 11.740 for Europe; at 1930-2000, 2300-2330, and 0015-0100 on 9.570 for North America. However, Pearce heard a later announcement over the air from *Radio Warsaw* stating that an additional transmission in *English* is at 1630-1700 on 7.205. This 7.205 *English* period has been heard by Bellington, N. Y.; continued in foreign language, probably Polish, at 1700.

**Portugal**—*Emisora Nacional*, Lisbon, is noted on 15.380 at 0700 when Moscow closes on 15.390; signal strength improves by 0745 when Moscow returns to the air and then almost obliterates Lisbon to 0850; Lisbon closes 0900 but carrier remains to 0915 when a further program is presented to closedown which varies 1100-1130. (Suffolk, Australia, via Radio Australia) This one is good level mornings here in West Virginia; all-Portuguese. Recently measured 15.3825 at 0825, according to Oskay, N. J.

Noted on 9.747 and 11.958 at 1500-1530 and 1600-1800. (Harris, Mass.)

**Portuguese Guinea**—Bissau, CQM4, is still heard through bad CWQM on approximately 5.839 at 1630-1800; news in Portuguese 1715. (Pearce, England)

**Portuguese India**—Radio Goa, 9.61, has good signal in South Africa at 0900-0930 (*English*); at 0930 has Portuguese announcements; commercials are used; station has confirmed schedule as 2030-1230, but can be heard in South Africa only after 0900 when SABC's *Springbok Radio* (commercial service) on 9.60 leaves the air to continue on 7.295. (Ridgeway)

**Yours FREE!**  
TV PICTURE-PATTERN SERVICING BOOK!

Coyne Electrical & Television-Radio School  
500 S. Paulina St., Dept. 51-T3, Chicago 12, Ill.  
Rush "APPLIED PRACTICAL RADIO-TELEVISION" for 7-days' FREE Trial per your offer. Include FREE TV Picture Pattern Book.

Name \_\_\_\_\_ Age \_\_\_\_\_  
Address \_\_\_\_\_  
City \_\_\_\_\_ Zone \_\_\_\_\_ State \_\_\_\_\_  
Where Employed \_\_\_\_\_

( ) Check here if you want set sent C.O.D. You pay postman \$15.95 on delivery. We pay postage. Same Money-Back Guarantee.

**MAIL COUPON NOW!**

For Asking To See Coyne's New 5-Volume Set "Applied Practical Radio-Television" on **7 DAYS' FREE TRIAL!**

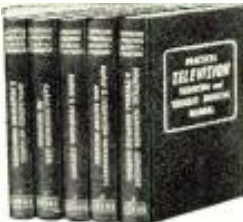

Here's a sensational "get-acquainted" offer. IF YOU ACT AT ONCE, a brand new TV servicing book, "TV SERVICING WITH PICTURE TUBE PATTERNS," is YOURS FREE. Shows dozens of actual TV picture tube photos and wave forms with clear explanations of what they mean and how to trouble-shoot and service faster. NOW YOU CAN GET A COPY ABSOLUTELY FREE just for asking to examine COYNE'S great 5-volume set APPLIED PRACTICAL RADIO TELEVISION for 7 days.

**5 Great Volumes of "Know How" That Make You Worth More**

If you want to "go places" in Television and Radio Servicing today, COYNE'S NEW 5-volume set, APPLIED PRACTICAL RADIO-TELEVISION can help you. It is the most complete, up-to-date set of reference books in America. See outline of some of the subjects covered in this great set in column at right.

APPLIED PRACTICAL RADIO-TELEVISION shows you how to install, service, shoot trouble, align all types of radio and television sets. Everything is clearly explained. "Break-down" photos and examples make sure you understand. Fully indexed for quick reference. Use this set FREE for 7 days—get FREE book of Television Picture Patterns for examining set.

**Offer Limited—Send Coupon Now!**

Send no money. Just mail coupon above for 7 days' FREE TRIAL on COYNE'S 5-volume set. We'll include the book of TELEVISION PICTURE PATTERNS. If you keep the set, pay only \$3.00 after 7 days' trial and \$3.00 a month until \$17.50 plus postage is paid. (Cash price \$15.95). If not 100% satisfied with set, send it back and you OWE NOTHING. EITHER WAY, THE BOOK OF TELEVISION PICTURE PATTERNS IS YOURS FREE TO KEEP. Coupon is just a request to see the set and get the FREE BOOK of TV Picture Patterns. This sensational offer is limited. SEND THE COUPON NOW!

**COYNE ELECTRICAL & TELEVISION-RADIO SCHOOL**  
An Institution Organized Not For Profit  
500 S. Paulina St., Dept. 51-T3, Chicago 12, Illinois

**RADIO & TV FROM A TO Z**

Look at this partial list of subjects in Coyne's new "Applied Practical Radio-Television":

Color Television  
Testing Instruments  
UHF Channels  
Converters & Adapters  
Phono Pickups  
Auto Radios  
TV Cameras,  
Tubes, Receivers  
P.A. Systems  
General Principles  
Resonance & Tuning  
Radio Circuits  
Receiver Controls  
Short-Wave  
Capacitors & Capacitance  
FM Receivers  
TV Picture Patterns & Wave Forms  
1600 Pages—900 Illustrations

Never before has a set of books covered the field so completely, been so easy to follow.

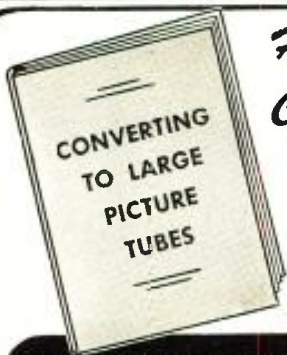

*Here it is! First Complete Conversion Book in America!*

Just off the press! The first complete book published in all America that gives you all the facts ... all the photos ... all the diagrams you need to convert 10" or 12" television sets (RCA, Philco, GE, Admiral, Crosley and many others!) to big 14", 16" and even 20" picture tubes! Simple and easy to follow!

**A VITAL "MUST" FOR EVERY TV SERVICE MAN!**

**"CONVERTING to LARGE PICTURE TUBES"**

ONLY \$1.50

POSTAGE PAID

There's big money for you when you learn to convert TV sets to big screen this easy way. This new book tells all you need to know ... solves problems quickly ... expertly. Get your copy now!

**SOLVES EVERY PROBLEM OF TV CONVERSION!**

- Focus
- Linearity
- Width
- Height
- Centering
- Blanking
- Cabinet Modification

*Order Your Copy, Today!*

AMERICAN DISTRIBUTING CO., DEPT. RN-5  
1810 WINCHESTER ST., BALTIMORE 17, MARYLAND

I am enclosing check or money order for \$ \_\_\_\_\_  
Rush \_\_\_\_\_ copies of "Converting to Large Picture Tubes" at once. (\$1.50 per copy, No C.O.D.'s.)

NAME \_\_\_\_\_  
ADDRESS \_\_\_\_\_  
CITY \_\_\_\_\_ STATE \_\_\_\_\_



## Here is a group of TRIAD Transformers Especially Designed for REGULATED POWER SUPPLIES

In the design of regulated power supplies, plate voltages, 100 volts or more in excess of those required for normal power supplies, are needed. In addition, the tube filaments are operated at differing potentials, requiring several separate filament windings.

The following new plate and multi-filament transformers, used in connection with standard higher voltage plate transformers and chokes now available, will permit design of a wide range of regulated supplies.

### POWER TRANSFORMERS

Type No	Pr. Volts	Sec. Volts	Fil. No 1	Fil. No. 2	Fil. No 3	Fil. Po 4
R-26A	115	880 720V C.T. @ 200 Ma	6.3V C.T. @ 8A.	6.3V. @ 3A.	6.3V. @ 1A	5V @ 3A.
R-28A	115	1250V C.T. @ 300 Ma	6.3V C.T. @ 8A.	6.3V. @ 3A.	6.3V @ 3A	5V. @ 6A.

### FILAMENT TRANSFORMERS

Type No	Pr. Volts	Fil. No 1	Fil. No 2	Fil. No 3	Fil. No 4	Fil. No 5
F-34A	115	6.3V C.T. @ 1.75A	6.3V @ 1.75A	6.3V @ 1.75A	6.3V @ 1.75A	6.3V @ 1.75A
F-36A	115	6.3V C.T. @ 3.5A	6.3V @ 3.5A	6.3V @ 3.5A	6.3V @ 3.5A	6.3V @ 3.5A
F-38A	115	6.3V C.T. @ 5A	6.3V @ 5A	6.3V @ 1A	5V C.T. @ 2A.	5V @ 4A.

These and other Triad Transformers are described in

Catalog TR-51, just off the press. Write for your copy today.



2254 Sepulveda Blvd.  
Los Angeles 64, Calif.

**Saudi-Arabia**—Djeddah noted on 11.85 and 11.95 recently at 1240 in Arabic; good on both channels; also noted on 11.85 at 0245 but with bad QRM from Oslo. (Bellington, N. Y.)

**South Africa**—What appears to be Johannesburg, 4.895, opens with Afrikaans program at 2345; fair signal here in West Virginia; also heard in New York by Bellington, N. Y., Saylor, Va., others. SABC, Johannesburg, was noted recently on 11.937 with news 1500-1504, signed off 1505; asked for reports; bad CWQRM. (Oskay, N. J.) Some days carries Afrikaans instead of English.

**Springbok Radio** (commercial service) is scheduled 2300-0015 on 4.945; 0015-0245, 7.295; 0245-0900, 9.60; 0900-1100 and 1100-1600 (Sats. to 1700) on 7.295. (Ridgeway, South Africa)

**Spain**—A recent *World Radio Handbook Bulletin* said that *Radio Nacional en Malaga*, 7.022, shortly would begin broadcasting an *English* program at 2100; may have been effected by this time. At the time this was compiled, *Radio Nacional de Espana*, Madrid, had just moved from 9.369 to 9.585 where signal was much improved; *English* is still at 1515, 1810.

**Sweden**—"Sweden Calling DX-ers" goes on the air on Saturdays at 0215 on 6.065, 10.780; repeated 1015 and 2015 on 10.780. 6.065. (Radio Sweden) *Radio Sweden* recently changed frequencies to 6.065 and 10.780 for the 1900-2030 North American transmission and for the "morning" transmission at 0015-0235. (Radio Sweden)

**Tahiti**—*Radio Tahiti*, 6.135, still noted 2300-2345 sign-off; French news 2330. (Balbi, Calif.) Is heard with weak level here in West Virginia.

**Taiwan**—Taipeh, 7.133, puts in a fine signal 0400-0700; still has news 0630. (Grischott, Calif.)

**Tangiers**—*Radio Internationale*, 6.115, noted 1555 with program for French listeners; Spanish began at 1615; no *English* noted; has man and woman announcers and carries advertisements in French and Spanish. (Pearce, England)

**Trinidad**—VP4RD, 9.625. Port of Spain, now is scheduled 0500-2200, according to verification received. (Radio Sweden)

**USSR**—*Radio Tashkent*, 6.825, noted in *English* 1115-1130, news commentary; however, announces *English* periods for 1000 and 1045. (Pearce, England) What appears to be the Soviet Home Service on 7.180 leaves the air 2345, at least some nights. (Bellington, N. Y.) *Radio Sweden* says a Soviet station is now operating on about 10.040; may be Alma Ata.

**Radio Moscow** noted with news 0115-0130 on 6.110, underneath BBC. (Lane, South Dakota) Heard on 7.165 with news 2230. (Harris, Mass.) Grischott, Calif., reports Ashkarabad, 6.180, with *English* 0930; verifies in 30 days.

**Vatican**—HVJ noted back on 11.74 from 11.66 with *English* 1315-1330; at 1330 announced next broadcast would be in 15 minutes in French on 31.10, 41.21, 50.26, and 19.6 meters, and next

## TRIPLE POLE DOUBLE THROW KNIFE SWITCH

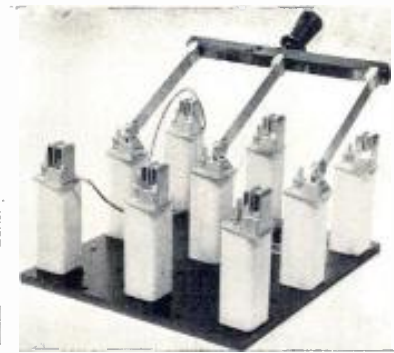

Mounted on 7"x8"x1/4" bakelite. Statite insulators. Heavy duty copper blades with double contact copper spring receptacle to match. Mfg. Square Co., as Signal Corps Antenna Switch, SW-225. Brand new in original packing. Shipping wt. approx. 5 1/4 lbs.

Original cost—more than \$10.00.

NET PRICE—\$1.75 EA.  
4 for \$6.25

DAVID GROSSMAN CO.  
3510 Devonshire Dr. Baltimore 15, Md.

LEARN DAY and EVENING CLASSES  
**TELEVISION**  
ELECTRONICS-RADIO  
Modern Laboratory Instruction in

- SERVICING
- BROADCAST OPERATING
- ELECTRONIC and TV ENGINEERING

WRITE FOR ILLUSTRATED CATALOG  
**ELECTRONICS INSTITUTE, Inc.**  
21 HENRY, DETROIT 1, MICH.

G.I. APPROVED

**EVERY RADIOMAN**  
Can Use These  
**SERVICE HINTS!**  
Valuable Manual Yours—FREE!

Every page of "How to Simplify Radio Repairs" is packed with on-the-bench, practical ideas. Contains photos, charts, diagrams—no fluff—no vague theory. In plain every-day language it gives you priceless suggestions—new servicing ideas. You'll use and benefit from the experience of experts. Partial list of contents: How to Localize Trouble; How to Service Amplifiers; How to Test for Distortion; How to Test Audio Circuits; How to Test Speakers; How to Find Faults in Oscillators; How to Test Radio Parts—and it's all yours—FREE! No obligation.

**FEILER** SEND COUPON OR PENNY POSTCARD FOR YOUR FREE COPY TODAY!

FEILER ENGINEERING CO., Dept. 5M1  
8026 N. Monticello Ave., Skokie, Ill.  
(Suburb of Chicago)  
Please RUSH my FREE copy of "How to Simplify Radio Repairs."  
Name .....  
Address .....  
City..... Zone..... State.....

RADIO & TELEVISION NEWS

English for the next day at 1000 in the 19-, 25-, and 31-m. bands. (Pearce, England)

Venezuela — YVKF, 4.880A, heard well 2330; slogan is "Ondas Populares;" YVKM, 5.040. *Radio Continente*, heard well 2200. (Callarman, Oregon) YVKF has a show in *English* on Monday and Friday at 1800-1830 ("The 960 Club"); asks for requests for tunes; more recently announced this session would be aired also on Wednesdays. (Fox, D. C.) YVKD, 5.0528V, measured 0620 when had music; station announcement in Spanish at 0615; previous measurement was 5.062. (Oskay, N. J.)

**Last Minute Tips**

At the time this was compiled, *Radio Sweden* reported that the new 100 kw. transmitter at Moydrum, Athlone, Ireland (Eire), was ready for use but there had been no word from official sources regarding the opening. I was hearing the low-powered 17.84 outlet some days with news 1330-1345A, with QRM from Brazzaville.

Stark, Texas, and Bellington, N. Y., have been hearing a station in *English* on approximately 4.960-4.965 evenings around 1800-1930 that seems to be Belize, British Honduras.

A station noted occasionally around 2300-2330 on approximately 6.087 may be Tabriz, Iran; one opening 0030 and usually closing 0045 (0050 other days) on 6.275 mentions Yugoslavia. (Bellington, N. Y.)

\* \* \*

**Press Time Flashes**

*Radio Kol-Israel* plans to inaugurate its new high-powered (50 kw.) m.w. and s.w. station on Israel's Independence Day, May 14. The s.w. station has been allocated 21.465, 17.880, 15.415, 11.935, and a frequency in the 31-m. band (9.500, 9.615, 9.640 have been tested). The m.w. station has been assigned 1025 kc. In addition to carrying the regular short-wave service, the new 50-kw.-er also will relay the "Voice of Zion" (*English*) session now heard 1700-1745 daily over (announced) 9.000 (measured 9.012V), Tel Aviv. (Bert Bluman, Israel, via Radio Australia) Listen for more details which likely will be given during the weekend prior to May 14—over stations which have regular DX programs—*Radio Australia*, *Radio Sweden*, Leopoldville, Copenhagen, possibly others. —KRB.

At press time, on request, we received a special report on Far East DX from August Balbi, Los Angeles, Calif.; space will not permit use of all the fine items, but here are highlights:

China—A station on 5.915 may be Mukden (?), heard with bad CWQRM after 0500, weak to fair. Communist Chinese stations are numerous and schedules are irregular. Those on 7.10, 6.10, 5.985 (Shanghai), appear to sign on at 0400; the 9.73 (Nanking), 7.000, 6.155, 6.65 outlets sign on 0430; some are parallel when news in Chinese is given, usually

May, 1951

# "When did you last change your Phono-Cartridge?"



That's your \$70 (Million) question, Mr. Service-Dealer!

Right now . . . 10,000,000 old style, heavy, stiff-acting phono-cartridges in existing record players are *obsolete*. They limit reproduction. They rapidly wear out valuable records. They should be replaced immediately with *modern, lightweight, compliant* cartridges that guarantee greater record enjoyment, longer record and needle life. Current cartridges that operate inefficiently should be replaced, too.

So check the cartridge on every job . . . ask every record player owner this simple question: "When did you last change your phono-cartridge?" You'll render a service your customers will appreciate—you'll sell replacements like never before—you'll make more money!

Now for better playing, record saving performance . . . REPLACE . . . MODERNIZE with easy-to-install E-V Cartridges. Exclusive features of E-V Torque Drive make it ideal for fast and slow speed records. Has extra-high voltage-compliance ratio. No bearings or bushings to deteriorate. Simplified design permits maximum replacements with fewer models. Single and dual needle types. Used today in original equipment of many leading manufacturers.

**Make the Finger-Tip Compliance Test**



Modern, compliant needle system



Old style, stiff-acting needle system

## Electro-Voice

410 CARROLL STREET • BUCHANAN, MICHIGAN  
Export: 13 East 40th St., New York 16, N.Y., U.S.A. Cables: Arlab



**FREE!**

**REPLACEMENT CHART**  
Large, Complete Replacement Chart. Gives handy cross-reference and valuable data. Tells when to replace a phono-cartridge. Ask your E-V Distributor or send for it now.

Electro-Voice, Inc.  
410 Carroll St., Buchanan, Michigan  
Send FREE Cartridge Replacement Chart

Name.....  
Address.....  
City..... Zone..... State.....

N5-1

Not a kit, but a complete chassis  
assembled and checked  
by professional experts

**14** reasons why our  
**RCA type 630**  
chassis is your  
best TV buy!

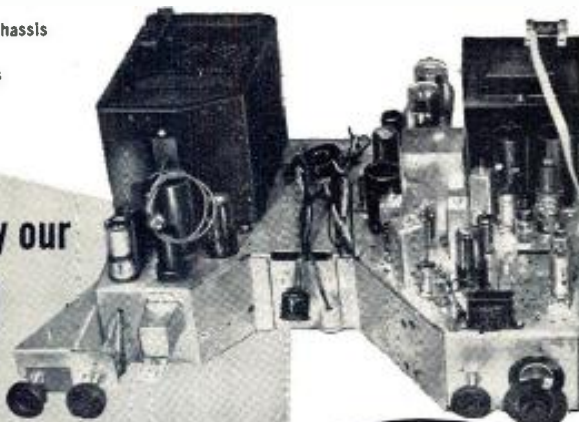

Don't buy any TV chassis until  
you check our low prices!

Special Offer: 17" and 20" Picture Tubes  
at the lowest prices in the country!

manufactured by

**TRAD TELEVISION CORP.**

*Tradtel*

sold by

**DISTRIBUTORS, INC.**

a division of TRAD TELEVISION CORP.

Dept. N-5, 1001 First Avenue Asbury Park, New Jersey  
Asbury Park 2-7447. In New York, Worth 4-1197

1. 30 tubes—27 tubes, 3 rectifiers
2. AFC horizontal hold, featuring Syncrolok
3. High voltage doubler circuit
4. Maximum brilliance with any picture size up to 20"
5. Co-channel sound, featuring good limiting for maximum noise immunity
6. Keyed AGC (using extra 6AU6 tubes), minimizes airplane flutter, keeps picture level constant and uniform when switching from channel to channel
7. Overall band width four m. c. for maximum definition and picture crispness
8. Original 630 sync chain for maximum picture stability
9. Molded condensers throughout
10. Full complement of electrolytics as specified in original design
11. Focus coil and yoke assembly with removable plugs for easy servicing
12. Top quality video amplification assuring good contrast range for full "blacks and white"
13. Same chassis used in highest-priced sets and custom installations
14. Complete with mounting hardware ready for installation



## HENRY HAS THE NEW hallicrafters MODEL S-77 NOW!

### LOW-COST HALLICRAFTERS MODEL S-77



Temperature compensated oscillator; tuned r-f stage, two i-f stages for better selectivity. Covers 540 kc to 43 Mc in four bands. Sensitivity, volume, three-position tone, BFO Pitch, controls; AVC, BFO, Rec./Standby, and Noise Limiter switches. Built-in PM speaker. Gray steel cabinet, 18 1/2" wide, 9" high, 9 1/2" deep. Piano hinge top. External power, remote control connections. 7 tubes plus rect. This is AC/DC version of popular S-40B. For 115 V. AC/DC. \$99.95



### NEW DUAL-CONVERSION RECEIVER HALLICRAFTERS Model S-76

Note these features: Dual conversion (1650 Kc and 50 Kc)—more usable selectivity than the best crystal. Giant 4-in. "S" Meter—calibrated in microvolts and "S" units. Four bands 538-1580 Kc, 1720 Kc to 32 Mc. Calibrated electrical bandspread. 5 position selectivity. Sensitivity 2 microvolts or better with 5 watt output. 9 tubes plus regulator, rectifier. \$169.50.

I have a complete stock of Hallicrafters receivers and transmitters. I'll make you the best deal on a trade-in for your communications receiver. I give you prompt delivery, and 90-day FREE service. Nobody can beat Bob Henry on a trade-in, and I offer you the world's lowest credit terms. Write, wire, phone, or visit either store today for the best deal. Export orders solicited.

*Bob Henry*  
WPARA

Builer 2, Milford

**HENRY RADIO STORES**

1128 Olympic Blvd.  
LOS ANGELES 25  
CALIF.

"WORLD'S LARGEST DISTRIBUTORS OF SHORT WAVE RECEIVERS"

at 0830; at other times have different programs. One on approximately 6.35 signs on 0600 and carries all-Chinese; sign-off of most is 1000 except 7.10, 6.10, 10.26, 11.685, used for traffic besides regular transmissions. *Hong Kong*—ZBW3, 9.525, signs on 0500 in Chinese; relays Radio Newsreel from BBC, London, 1000, and signs off 1015. *Indo-China*—Radio France-Asie, Saigon, in 31-m. band varies in frequency; at press time was being heard on approximately 9.545 (announced 9.524) signing off 0415, back at 0515 and with final sign-off around 1028; French Vietnam, 6.165, 9.62, has news 0915, signs off 0930. *Japan*—Noted irregularly on 6.19 after 0300; heard calling JKH over and over again at 0345, evidently used for traffic; bad QRM after 0400. *Malaya*—Radio Malaya, Singapore, is heard now only on 6.135 and 4.785, in native. FEBS, Singapore, noted 0415-1100 on 15.30, 11.88, 11.69, 6.175, news 1045; sign-off is 1130. *Pakistan*—Radio Pakistan noted on approximately 11.73 from 0940; news 1015; signs off 1035. *Taiwan*—BED4, 11.735, Taipei, signs on daily 0430; news 0630; weak to fair signal; 7.133 parallels, both heard as late as 1100; one on 3.22 is heard weakly at 0500, irregularly, and does not carry 0630 news; 15.235 and 11.735 are noted 2300-0100 (first hour *English*), news 2303; the 11.735 seems to have Chinese now after 0100 as has been noted signing off 0200 in Chinese. *USI*—YDE, 11.77, Djakarta, noted signing on 0430; has *English* 1000-1100, news 1030; YDQ2, 9.55, Makassar, signs on 0400; YDB3, 7.27, heard weak to fair after 0430, still on 1045; YDF, 6.045, signs on 0430, fine signal; off 1030; no *English* noted on 6.045. *USSR*—Petropavlosk, 6.07, now heard only 0300-0400 in Russian. 0530-0615 in Chinese, with 4.275, 8.82 parallel in Chinese period; Moscow noted on 6.055, with 6.115 and 9.545 parallel, signing on 0230 and off 1000, with Chinese and Japanese programs; 11.83 heard signing off in Chinese 1000; Home Service, 9.37, 9.565, 5.94, 5.72, 5.02V, 4.96, noted after 0230; irregularly, 9.565, is heard in Chinese also around 0300.

Fox, N. Z., asks help in identifying a station on 3.960 from around 1430; has piano note interval followed by "bird whistle" at 25 minutes after the hour and 5 minutes before the hour; language appears Italian. However, Cushman, also N. Z., appears to hear the same station but lists frequency as 3.910 and says he believes it is *Radio San Marino*; programs are similar to those of *Radio Andorra* and *Radio Monte Carlo*; noted from before 1300 to fade-out around 1500; at 1400-1430 has frequent commercial announcements interspersed with brief musical items; 1300-1400 uses French, and from 1400 is in Italian. (Radio Australia)

*Radio Pakistan*, Lahore, has been logged on 4.810 at 1015 when relays news from Karachi.

Lourenco Marques, Mozambique, is noted in 60-m. band daily with *English*, parallel 11.764, around 2300-2400 or

**RADIO & TELEVISION NEWS**





# SHORTAGES? HIGH PRICES? BEAT 'EM WITH NIAGARA "SUPER" BUYS!

**NEW BARGAIN FLYER  
JUST OFF THE PRESS!**

Keep up-to-date on "Best Buys."  
Ask for your FREE COPY today!

## OIL-FILLED CONDENSERS

Leading Brand Names  
All Brand New—  
GUARANTEED



Cap.	D.C. Volts	No.	Net Each
.005	15,000	14F322	7.95
.005-.005-.01	10,000	26F116R2	10.50
.01	10,000	AX1136	7.50
.02	15,000	14F321	21.95
.01	6,000	143-806	7.50
.15	2,500	26F345	1.10
.2	5,000	C8B284	2.98
.25	4,000	14717	3.10
.25	10,000	14F192	19.50
.6	2,500	72041-503	1.25
1	440 AC	K01410	.59
1	2,500	482616-10	2.55
1	5,000	A1080	2.75
1	3,000	C8B3062	2.95
1	5,000	26F49-412	3.15
1	6,000	T60019GA	4.35
1	12,000	26F628	9.50
2	440 AC	67x21	.79
2	600	A1109-2	.85
2	1,000	23F11	1.10
2	2,000	324-138	2.20
2	3,000	2538-16	4.50
2	5,000	G-8B2784	6.50
2.5-2.5-5	600	C8B1256	1.95
4	330 AC	KG3040	.85
4	400	25F785	.95
4	600	14B1253-1	1.10
4	1,000	10365	1.75
5	1,000	13765	1.85
6	330 AC	67x7A	.89
6	41 AC	K64000	.95
6	600	P9718	1.75
8	1,000	143-117	2.50
8	2,000	TJ120080G	4.95
10	400	70B1AE1D	1.25
10	600	11873	1.85
15	1,000	26F1962	3.95

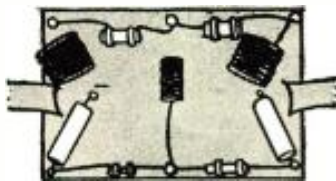

## BANISH INTERFERENCE with NIAGARA Famous HI-PASS FILTER

Positive protection against interference from amateur transmitters, diathermy and all other devices generating radio frequency interference below 40 Mcs. Designed for 300-ohm lead-in. No loss in brightness or clarity.

Wired and Tested..... **\$2.95**  
Postpaid if entire amount is included with order.

## "SNAP-OUT" MOBILE WHIP ANTENNA (AN-131-A)

Eight tubular brass sections bonded together by a braided steel cable. Measures 136" extended, collapses to a compact 17 inches. Bottom section fitted with standard 3/8" thread. Will fit most popular automobile antenna mounts.

WHILE THEY LAST..... **\$2.49**



## A NIAGARA SPECIAL

### A STANDARD TYPE TV TUNER



Exceptional value in a 12 channel turret tuner or front end. This high gain, low noise tuner is designed for receivers with 21.25 or 21.9 MC I.F. Drum type turret has replaceable channel coil and contact strips. Fine tuning is provided with stop at each extreme. Guaranteed to last for years and years. Will replace any tuner. **DOUBLE YOUR MONEY BACK** if replacement detent is ever required. Tuner uses 1-6AK5 RF and 1-6J6 Mixer-OSC.

WHILE THEY LAST **\$12.95**  
Less Tubes .....  
With Tubes ..... **\$14.95**

## LIMITED QUANTITY

## New Shipment! ARC-5/R-28 2-Meter Receiver

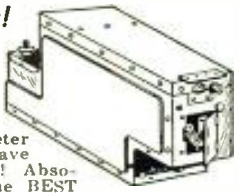

Here is the 2-meter superhet you have been looking for! Absolutely one of the BEST available today! Tunes from 100 to 156 Mcs. in four crystal channels. (Easily converted to continuous tuning.) Tube lineup is as follows: 717A-R.F., 717A-Mixer, 2-12SH7—1st and 2nd I.F. (6.9 Mc.), 12SL7—Det-AVC-Squelch, 12SL7—1st audio-squelch amplifier, 12A6—2nd audio, 12SH7—R.F. Osc.—4th Harmonic Gen., 717A—Trip, 12th Harmonic Gen., 717A—Dblr.—12th Harmonic Gen. A highly desirable superhet, made of rigidly inspected parts and contained in a louvred aluminum cabinet measuring 7 5/32" x 4 3/4" x 14". Complete with all tubes in original sealed cartons..... **\$29.95**

FOR A LIMITED TIME ONLY!

With each order for ARC-5/R-28 Receivers, one copy of Vol. 2 "Surplus Radio Conversion Manual" (Regular price \$2.50) will be shipped at no additional cost! This volume contains circuit diagram and full description of above receiver, plus a wealth of conversion data on many other popular items of surplus equipment. Act Now, for Your \$2.50 Bonus!

## TUBES NEW—BRANDED—GUARANTEED LARGE STOCK RECEIVING—TRANSMITTING INDUSTRIAL LOW PRICES Quotation on Request

## TRANSFORMER BARGAINS (ALL WITH 110 V. 60 CY. PRI.)

PLATE		Price	
511-T1	330-0-330 600MA	\$ 5.75	
D-161913	2500V @ 4MA (TV OR SCOPE)	3.95	
S-13336	2500V @ 4MA. 6.3V @ .6A. 2.5V @ 1.75A	9.95	
D12A-2786	1500V @ 4MA. ELECTROSTATIC SHIELD. BERN. SEAL.	4.95	
FILAMENT		Price	
T-2	2.5V @ 10A	3.95	
52B049	5VCT @ 3A. 5VCT @ 10.5A. 0.3VCT @ 3.5A	4.50	
475-T201	5VCT @ 15A	5.95	
68-G-65	2.5V @ .005KV @ 7.5KV INSUL.	12.95	
K93451	6.3 & 2.5V @ .0107KV @ 12.3KV INSUL.	14.95	
D-161917	0.3V @ 3A. 2.5V @ 2A	2.85	
P-4001	7.5V @ 5A	2.49	
POWER		Price	
P-8001	325-0-325 @ 10MA. 5VCT @ 2A.	2.25	
P-6009	275-0-275 @ 70MA. 5V @ 5A. 2.5V @ 10.5A	3.00	
T-47165	135-0-135 @ 60MA. 5V @ 5A. 5V @ 3A	2.49	
C-12A1100	350-0-350 @ 70MA. 6.3V @ 1.2A.	2.95	
T-4001	300-0-300 @ 125MA. 250-0-250 @ 75MA. 12.0V @ .6A. 5V @ 3.5A. 5V @ 3.5A	9.95	
BS-77-L	145-0-145 @ 55MA. 120V @ 35MA. 5V @ 3A. 5V @ 2A	3.49	
MODULATION		Price	
ARC-3	807RF TO PHILIP (8B1)	2.49	
A-3860	200. 500 OHMS TO 5, 6, 7, 8, 9. 10K OHMS-150MA	4.49	
ART-13	P.P. 813 MODULATIONS TO SINGLE 813 (Some Insulators damaged, but guaranteed to work)	9.50	
DRIVER		Price	
A-4205	10,000 OHM PLATE TO SINGLE GRID	.79	
OUTPUT		Price	
SP-12	P.P. 6V6 TO 8 OHM VOICE COIL	.79	
T-46235	P.P. PAIR. 6X7 "B" TO 8,000 OHMS	1.75	
511-T1	6V6 TO 8 OR 600 OHMS	.85	
F-20003-1	P.P. OR SINGLE 6V6 TO UNIV. LINE OR V.C.	2.49	
INPUT		Price	
T-47368	600 OHM C.T. TO 300 OHM MIKE.	1.29	
A-4350	MIKE TO LINE	2.49	
T-47369	30 OHM MIKE TO 600 OHM C.T. SEC.	1.65	
CHOKES		Price	
7470653	1.46 HY	1.50	
L-143	1.72	4 AMPS	6.50
C-2303	2.5	100 MA.	9.95
475-CH301	3.8	75 MA.	1.25
32584	6	200 MA.	2.35
15406	12	225 MA.	2.95
510K2	15	200 MA.	2.65
11-C-43	16	50 MA.	.95
L-218	45	90 MA.	2.75

## NIAGARA IS C.A.P. H.Q.

### GET A LYSCO C.A.P. TRANSMITTER



2374 KC, 25 Watt peak. Rounded drawn black wrinkle finish case. Silk screened, white lettered panel. Features lightweight (3 lbs.), antenna changeover relay. 50 Ohm co-ax output. Requires 500 V.D.C. @ 125 MA. 6.3 V. AC/DC @ 1.35 Amps Fil. for models A140 and B140. C140 requires same 500 V. plus 12.6 V. AC/DC @ .45 Amps Fil. Panel controls include Fil. Sw., Osc. tuning, P.A. tuning, meter and mike jacks and xtal socket. Modulated by new clamp type amplitude system. Measures 4" wide, 4 1/2" high, 6" deep.

Model A140—  
Less Tubes (3-6AQ5)..... **\$29.95**  
Model B140—  
Less Tubes (3-6V6GT).....  
Model C140—  
Less Tubes (3-12A6).....  
6AQ5—\$1.20 Ea., 6V6T—\$1.20 Ea., 12A6—\$1.74 Ea.

**NOTICE**  
Minimum Order \$5. 20% deposit with orders unless rated. F.O.B. N. Y. C. Prices subject to change without notice.

**Guarantee**  
Niagara's Guarantee of Satisfaction  
All items must meet with full approval or money refunded.

**Niagara Radio Supply Corp.**

Phone  
Dlgy 9-  
1132-3-4

Dept. RN-51

160 Greenwich Street, New York 6, N. Y.

# GET AHEAD FASTER IN RADIO-TELEVISION ELECTRONICS

Use the HANDBOOKS  
the EXPERTS USE



The library set assists you in every operation in radio, television and electronics. Gives you the fundamentals, complete groundwork, understanding of all types of radio, television, electronic gear and their circuits, including theory of operation.

Shows you expert methods of planning, building, installing, operating, testing, adjusting, and servicing. The know-how of radio, television and electronics presented in plain language and simple terms with easy to understand pictures and working diagrams.

Complete Data Section containing hundreds of pages over all. Color codes, cable charts, wire tables, screw sizes, mounting dimensions, symbols, abbreviations, charts, graphs, tables, formulas, standards, and vacuum tubes including cathode ray tubes.

You get 1800 pages of basic knowledge, methods and data of radio, television, electronics completely illustrated with over 2000 pictures, drawings, codes, charts and graphs.

Written by the Boyle-Roche experts who make electronic manuals for the U. S. Signal Corps.

**RADIO & ELECTRONICS HANDBOOK** provides instruction and reference on fundamentals, parts, tubes, circuit elements, receivers, transmitters, amplifier systems, power supplies, antennas, meters, test equipment, and accessories, with complete Data Section.

**VIDEO HANDBOOK** reaches television and provides complete handbook reference on all phases with full sections on principles of television, receivers, antennas, test equipment, servicing, pattern interpretation, transmitters, show production and more.

**SEND NO MONEY  
10 DAY FREE EXAMINATION  
SPECIAL OFFER**—Save one dollar. Get both books described above in handsome slip case as shown for only \$10.90 (Only while special Library Set offer lasts.)

**BOYLE-ROCHE BOOK CO.**  
CALDWELL 25, NEW JERSEY

Send ( ) Library Set @ \$10.90  
( ) Radio & Electronics Handbook @ \$5.95  
( ) Video Handbook @ \$5.95

In ten days I will send you price plus postage or I will return book(s) postpaid. (Offer good only in U.S.)

Name.....  
Address.....  
City, Zone, State.....  
Employed By.....

Save postage. We pay postage if you enclose full price now. Money back on same return privilege.

later; frequency is listed 4.932 but seems as low as 4.913 at times.

DZH5, 9.690, "The Voice of the Catholic Philippines," University of Santo Tomas, Manila, was acquired from the Philippine Broadcasting Corporation on Sept. 17, 1950; staff consists of amateurs from the University and the station is non-commercial, existing for cultural, educational, and training purposes. DYH4, 6.055, broadcasts missionary programs 0500-1000 and is operated by Sillman University in Dumaguete City. (Cushen, N. Z., via WRH Bulletin)

ZNX32, Bridgetown, Barbados, used only on occasions to relay sports events, was heard recently on measured 7.547, closing down 1635. SABC's 25-m. outlet announced as 11.927 has been measured as 11.938 around 1430-1505 when closes. Although Pan-American Radio, Tangiers, announces 15.048, it has been measured 15.038 when signing off tests at 0832. (Catch, England)

"The Short-Wave Station Free Russia," clandestine, operates on 45 meters daily 0630-0700; programs in Russian and German are dedicated to Underground organizations in the Red Army and in the Russian Zone of Germany.

APK3, 11.884, Karachi, Pakistan, noted with native music and leaving the air suddenly, without announcement, at 2125. ZBW3, 9.524, Hong Kong, noted with weather report 1029 and closing down with "God Save the King." (Russell, Calif.)

HI9B, 6.000, can be heard 1100-2030 in Spanish; QRA is HI9B, Broadcasting Hotel Mercedes, Santiago de Los Caballeros, Dominican Republic. (Kroll, N. Y.)

Radio Eirrean, Dublin, "says" it is on 15.120 at 1710 and on 17.840 at 1330 with news; however, only the 1330 period on 17.84 is heard. (Peddle, Newfoundland)

Flavio Serrano, ISW monitor in Rio de Janeiro, is now employed by Radio Quitandinha, Petropolis, Brazil, in charge of correspondence between the station and its listeners; wants more reports from USA, with numerical ratings even if reception is poor. Serrano says Radio Nacional, Rio de Janeiro, has a QSL card (sent along a sample) and wants reports; says an IRC is not necessary; when the new 50 kw. s.w. transmitter comes on the air in late 1951 or early 1952, the English program will be resumed; due to reduced QRM from Moscow on 9.72, PRL7 will remain there instead of moving to 9.505, as indicated earlier.

The new Chilean, CE1515, 15.15, is scheduled irregularly; heard as early as 0700 and as late as 2200; is "Radio Corporacion." (Serrano, Brazil) Has good signal in U.S.A.

Moscow frequencies now used to North America evenings are 11.89, 15.23, 9.76, 9.67, 7.28, 7.25, according to announcement; 6.010 has been dropped and 7.290 is not in use until 2100; others are used 1820-2300; the "Moscow Mailbag" is Saturdays 2100-2130. (Grischott, Calif.)

Springbok Radio, 4.945, South Af-

## TV KITS



**BIG SCREEN TELEKITS**  
NOW ONLY \$79.95 LIST

It's easy to own your own big screen receiver. Over 20,000 TELEKITS have been assembled. Big illustrated, easy-to-follow instruction book guides you step-by-step through easy assembly. TELEKIT #219 C uses 19" or 20" inch tube. Has wide-angle 70° electro-magnetic deflection. Gives brilliant picture. Has hum-free, high-fidelity intercarrier sound. Automatic Gain Control. A.F.C. horizontal hold control. New high sensitivity, low power consumption circuit. Kit complete, with all parts, less tubes. \$79.95 list. Write for free catalog with confidential dealer prices.

**BIG SCREEN CONVERSION KIT, \$12.95**  
Here's all you need to convert to big screen television. Comes complete with easy instructions for conversion of any brand set. Write "Dept. A" for FREE catalog of conversion kits, TV Parts, scarce TV Tubes, Picture Tubes and accessories, and Antennas all listed at confidential dealer prices.

## TELEKIT

**ELECTRO-TECHNICAL INDUSTRIES**  
1432 N. BROAD ST. PHILADELPHIA 21, PA.

**DOUBLE CHOKE-NAVY SPEC RAYTHEON TYPE WX 5146**  
Sec. #1—1.5 Hrs. @ 400 ma.  
Sec. #2—1.5 Hrs. @ 400 ma.  
3 1/2" x 4" x 7 1/2" wt. 15 lbs.  
21 ohms res. each sec. Hermetically Sealed. **995** each

**6V STORAGE BATTERY**  
Miniature—Wiltard—plastic case split proof design. Wt. 1 1/2 lbs. **295** each  
25% deposit—balance C.O.D.  
Write for Catalog  
**RADIO DEVELOPMENT & SALES CO.**  
323 Atlantic Ave. Brooklyn 2, N. Y.

## RADIO and TELEVISION

Over 30 years N.E. Radio Training Center. Train for all types FCC operators' licenses. Also Radio and Television servicing. FM-AM broadcasting transmitters at school. Send for Catalog M.

**MASS. RADIO SCHOOL**  
271 Huntington Avenue Boston 15, Massachusetts  
Lic. by Comm. Mass. Dept. Educ.

## Diamond Phono-Needles

• The one perfect phonograph needle is the Professional Diamond.

Professional, broadcast-station-quality Diamond Needle offers you: 1) elimination of record wear, 2) continuous high-fidelity reproduction, 3) savings up to several hundred dollars on sapphire or osmium needle replacements.

Purchase of a diamond needle can be the wisest investment you ever made . . . IF you get the best available needle!

**IMPORTANT FACTS TO REMEMBER**—Under a different trade name we manufacture the great bulk of the diamond stylus used in broadcast station equipment. Every stylus we make, regardless of its ultimate destination—radio station or individual user—is of the same unexcelled, unconditionally guaranteed quality. Our stylus should NOT be confused with five and ten dollar "diamond needles."

We can supply Professional Diamond Needles to replace practically any removable needle. (GE stylus we re-tip). Tandem-tip needles can be tipped with LP diamond only, if desired. In all cases sent used sample needle(s) with order. \$15.50 each, less 10% if both LP and 78 are ordered at same time. We can also supply cartridges with diamond stylus, changers, etc. Let us know your needs. Prices and information furnished without obligation.



**TELEVEX** 474 1/2 West 238th St.  
New York 63, N. Y.

**RADIO & TELEVISION NEWS**

rica, is being heard by Stark, Texas, and by myself in West Virginia around 2330 with commercial announcements, 3-note gong which is used frequently; fair level; uses *English* normally but may take *Afrikaans* on occasion. Should open 2300.

*Radio Nigeria*, Lagos, Nigeria, is scheduled weekdays 0100-0215, 0600-1700; Sundays 0100-1700; frequencies are listed 6.035, 7.255, 9.655. (Fairs, England, via *WRH* Bulletin) It is doubtful that the three frequencies are used simultaneously.—KRB.

*Radio Monte Carlo*, 6.035, 9.785, again opens daily 0100; usually closes 1710 but some days runs to 1735; normally, there is a break (silent period) around 0820 to 1145 or 1200.

TFJ, 12.175, Reykjavik, Iceland, is still heard with native program on Sundays only 1115-1145. (Sutton, Ohio)

JKL, 4.860, AFRS station in Tokyo, noted ending news 0630, then music. (Oskay, N. J.)

*Radio Tupi*, ZYC9, 15.370, Rio de Janeiro, noted 1909-1930, weak; distorted at intervals; frequent announcements in Portuguese. (Patterson, Ga.)

According to various sources, these countries or territories are reported to keep some form of "summer" or "day-light-saving" time (i.e., clocks are advanced 1 hour from Standard Time)—Albania, Balearic Is., Bermuda, Brazil (around Dec.-March), British Columbia, Canada (varies locally), Chatham Is., China (varies), Dominican Republic, Eire, French Morocco, Gambia, Germany, Gibraltar, Gold Coast (1/2 hour from Sept. 1 to Jan. 1, annually), Hong Kong, Hungary, Iceland, Ireland (Republic of), Israel, Japan, Korea, Lebanon, Libya, Monaco, Morocco (International Zone of), Newfoundland, Peru (Lima and Gallaco area from Jan. 1 to March 15, annually), Poland, Portugal, South Africa, Spanish Morocco, Syria, Turkey, United Kingdom, and United States (some areas; varies locally). (Allen, Mass.)

*Union Radio*, Havana, noted on approximately 8.880 now. Belize, British Honduras, is noted irregularly on approximately 4.965; news around 1925. *Radio Tananarive*, 9.695, Madagascar, is now audible after 2230; also noted from 2230 on 9.515. (Stark, Texas)

A station identifying as "Radio Internacional de Guatemala" has been heard on 6.260 at 0230-0300 with popular Latin and American dance music; fair signal; no location given; Hong Kong, 9.525, noted with BBC news relay from London 0600; *Radio Pakistan*, 15.335, has news 2100, fair level. (Rosenauer, Calif.)

YNWA, 6.460, 5a. Calle N.O.Y. 5a. Av., Managua, Nicaragua, verified via airmail; card is red, white, and blue. (Gerran, N. Y.)

\* \* \*

**Acknowledgement**

Thanks for the fine cooperation during the winter DX months; please keep your reports coming to me during the summer—at 948 Stewartstown Road, Morgantown, West Virginia, U.S.A. Thanks again! . . . . . KRB.

# Amazing POCKET RADIO NEW!

PUT THE WORLD'S BEST ENTERTAINMENT IN YOUR POCKET FOR YOUR PRIVATE LISTENING

LISTEN to your favorite program wherever you are in complete privacy with the tiny earphone. Enjoy these shows at home, in your car, outdoors anywhere without annoying anyone nearby.

PERFECT for bedtime, eating out alone, at sports events, at the theatre, or for the sick room. It's so small and light, it fits in your pocket like a cigarette case.

THRILL at its rich tone, clear tuning and power.



Weights less than 3 ozs. Incl. 2 flashlight batteries (small hearing-aid type)  
2 1/2" wide x 5 1/2" long x 3/4" thick  
4-tube performance  
Super-sensitive earphone  
Amazing tone quality  
40 miles-and-over daytime range  
Attractive case in handsome maroon plastic  
Built-in telescopic antenna—brilliantly blipped

Guaranteed! Complete for \$24.95. Includes Tubes & Batteries



RADIO & TV TUBES		RMA Guarantee—Boxed—		All Critical Numbers In Stock!		786 \$ .90		12BE6 \$ .98		12SR7 \$ .79		35Z3 \$1.19			
024	\$.83	1U5	\$.98	6AC7	\$1.98	6BE6	\$1.19	6K6	\$1.19	6U5	\$.98	7F7	\$.98		
1A7	1.19	1V	.98	6AG5	1.89	6BG6G	2.69	6K7	.69	6V6	.89	7F8	1.59	12K8	.49
1B3	1.95	1V2	1.49	6AH6	2.59	6BH6	1.25	6S4	.90	6W4	.98	12A6	.49	12SA7	1.10
1B5	.98	1X2A	1.49	6AK5	2.25	6B16	1.25	6SA7	.98	6W6	1.49	12A7	.39	12SF5	.69
1LA4	1.59	3Q4	1.08	6AK6	1.89	6BN6	1.75	6SC7	.98	6X4	.89	12A8	.39	12SF7	.69
1LB4	1.33	3Q5	1.38	6AL5	1.10	6BQ5	2.25	6SF7	.89	6X5	.75	12AL5	1.25	12SH7	1.10
1LN5	1.09	3V4	1.08	6AQ5	1.30	6C4	1.08	6SH7	.98	6Y6	1.20	12AT6	1.08	12SJ7	.79
1N5	.98	5U4	1.19	6AQ6	1.20	6CB6	1.10	6SK7	.98	7A4	.98	12A17	1.98	12SK7	1.10
1Q5	.69	5V4	1.89	6AR5	1.08	6CD6G	3.98	6SL7	.98	7A5	.98	12A06	.98	12SL7	1.20
1R5	1.20	5Y3	.69	6AT6	1.28	6D6	1.08	6SN7	1.59	7A6	.98	12A07	1.89	12SQ7	.98
1S4	1.10	5Y4	.89	6AU6	1.20	6F6	.98	6SQ7	.98	7A7	.98	12AV6	.98		
1S5	1.10	6A7	1.09	6AV6	1.20	6H6	.90	6SS7	.89	7A8	.98	12AX7	1.89		
1T4	.98	6AB	.98	6B4	1.35	6J5	.95	6T8	1.79	7B4	.90	12BA6	1.20		
1U4	.90	6AB4	1.19	6BC5	1.40	6J6	1.98	6U4	1.49	7B5	.90	12BA7	1.20		

Min. Order: 15.25"; dep. with C.O.D.'s. Include postage with order. All mds. subject to prior sale, F.O.B., N.Y.C.



## THE ROSE COMPANY

98 Park Place—Dept. R5      New York 7, N. Y.      Cortlandt 7-6195

IN UNIFORM OR IN ESSENTIAL INDUSTRY

# TOP JOBS & GOOD PAY IN RADIO-TELEVISION

Go to Men with Electronics Knowledge

**CREI Residence School Training** Offers You a Profitable Career

*In or out of the armed services, the best jobs go to the men with modern technical training. With electronics knowledge you're prepared for the future, whether you're headed for a berth in the Armed Services or a career in essential industry. Because of the critical shortages that exist today in the electronics field, the qualified technicians and engineers can practically choose their own jobs. Because of the dependence of modern armies, navies, and air forces upon electronics—for radar, communications, and navigation—the man with even limited electronics knowledge can get ahead quickly in uniform. In case of call to active duty before completion of your CREI course, you're still way ahead, since it is easier for the Services to complete your electronics training than start from scratch with an untrained man.*

At CREI you work with modern equipment—over 18,000 sq. ft. of class rooms, TV and radio studios, transmitters, control rooms, and labs. You're grounded in the funda-

mentals required for work in guided missiles, TV, communications, and other electronics fields. CREI's experience in training thousands for the Army, Navy, and Coast Guard in World War II, coupled with pioneering background in technical education and close industry connections, assure you of the best in technical preparation. New classes start twice a month. To insure your training, act right now. Send today for free catalog.

**RESIDENCE SCHOOL APPROVED FOR VETERANS**

*For most veterans, July 25, 1951 is the deadline DON'T DELAY!*

**MAIL COUPON FOR FREE CATALOG**

**CAPITOL RADIO ENGINEERING INSTITUTE**  
16th St. & Park Rd. N. W.  
Dept. 135C, Washington 10, D. C.

Please send free Residence School Catalog.

Name .....

Street .....

City .....

Zone..... State.....

Veteran  Non-Veteran  Age.....

Send details about Home Study Courses

# HARVEY

Features the Finest Brands  
At Most Reasonable Prices!

## WILLIAMSON HR-15 AMPLIFIER KIT



The famous Williamson HR-15 amplifier circuit... now available with the original Partridge transformers built to Williamson's specifications. Build this kit in 3 hours or less, and enjoy sound of a quality you never heard before. The HR-15 is a 2-Chassis power amplifier for use with tuners or other front ends having own volume and tone controls. All American triodes, 2-6SN7GT, 2-807, or 6BG6G in PP output, 5V4G rectifier. Response  $\pm .5$ db, 10-100,000 cycles. Output impedances 1.7 to 109 ohms in 8 steps. Absolute gain 70.8 db. 20 db. of feedback around 4 stages and the output transformers. Kit is complete with Tubes, Punched Chassis, Pre-wired Resistor Board, Sockets, Genuine Partridge Output Transformer, and All Necessary Parts.....\$75.00.

PARTRIDGE OUTPUT TRANSFORMER  
WVFB, as used in above Kit, available separately \$24.50

### Now in Stock! New Partridge CFB Series



Frequency response 3db down at 3 cycles and 95,000 cycles. Power rating 30 to 30,000 cycles at 60 watts with less than 1% distortion without negative feedback. Write for descriptive literature. \$35.60 JOBBERS... WRITE net FOR PRICES ON THE COMPLETE LINE OF PART-RIDGE TRANSFORMERS.

### Magnecorder — First Choice of Engineers! Magnecord Series 6 Recorders and Amplifiers

PT6-JAH Recorder and Amplifier the only combination that offers such high professional quality at such a low price.



Includes PT6-AH Recorder plus Amplifier with low impedance microphone and bridging inputs, 10 watt audio amplifier with monitor, speaker and jack for external speaker, 600 ohms balanced line output terminal.

PT6-JAH—Magnecord Combination with high speed forward.....\$564.00  
PT6-AH—Recorder with high speed forward.....\$316.00  
PT6-J—Amplifier.....\$248.00  
PT6-P.....Lightweight Portable Amplifier, including a record playback remote amplifier and power supply for use with the PT6-AH Recorder.....\$462.00

### McIntosh Amplifiers

We have McIntosh Amplifiers in stock for immediate delivery. Full information on request, or come in (if you're in town) for a demonstration.

20 W-2 Amplifier.....\$149.50  
50 W-2 Amplifier.....249.50  
AE-2 Equalizer Pre-Amp.....74.50

Prices Subject to Change Without Notice

Telephone: **hr** LUxemburg 2-1500

# HARVEY

RADIO COMPANY INC.

103 West 43rd St., New York 18, N. Y.

# MARS

# Station of the Month

## MARS BEAMS WEEKLY BROADCASTS

MARS—Army Headquarters station, WAR, located at the Pentagon Building, Washington, D. C., broadcasts a weekly message each Tuesday at 0100Z and at 0400Z. (This is Monday at 8 p.m. and 11 p.m., Eastern Standard Time; Monday at 7 p.m. and 10 p.m., Central Standard Time; Monday at 6 p.m. and 9 p.m., Mountain Standard Time; and Monday at 5 p.m. and 8 p.m., Pacific Standard Time.)

Simultaneous broadcasts are made on frequencies 3497.5 kc., 6997.5 kc., 14,405 kc., and 20,994 kc. Each message is sent three times, once at 10 words per minute, once at 15 words per minute, and once at a higher rate of speed—usually 20 words per minute.

Designed especially to transmit quasi-official traffic and training information to MARS members, the broadcast offers an excellent opportunity for all amateurs to build up their code proficiency.

**T**HE second annual Armed Forces Day will be observed May 19, 1951. The Army, Navy and Air Force have jointly arranged a special program for the radio amateur fraternity.

A receiving competition, identical with the one held last year will feature a message to the amateurs from the Secretary of Defense, broadcast on 12 military frequencies in International Morse Code, at 25 words-per-minute. Any listener may copy the broadcast and mail it to **ARMED FORCES DAY CONTEST**, Room 2B313, The Pentagon, Washington 25, D. C. All who make perfect copies will receive a Certificate of Merit, attesting their code copying proficiency. The following times, call letters and frequencies will be employed for the Receiving Competition (Eastern Standard Time has been used throughout): 2000 EST—AIR (Air Force Radio, Washington, D. C.), 14,405, 20,994 kc.; NSS (Navy

Radio, Washington, D. C.), 122, 4390, 9425, 12,630, 17,000 kc.; WAR (Army Radio, Washington, D. C.), 3497.5, 6997.5 kc. 2400 EST—AIR (Air Force Radio, Washington, D. C.), 14,405, 20,994 kc.; NPG (Navy Radio, San Francisco, Calif.), 115, 9255, 12,540 kc.; WAR (Army Radio, Washington, D. C.), 3497.5, 6997.5 kc.

Each transmission will be preceded by a five-minute CQ call. Should characters for any reason be transmitted with improper spacing, such as tape-punching errors, etc., such errors should appear in your transcription. It is not necessary to copy more than one station; no extra credit can be given for so doing.

### Military-to-Amateur Test

The Headquarters stations for the Army, Navy, and Air Force (WAR, NSS, AIR) will operate for a six hour period (1800 EST to 2400 EST) just

Major Lynn A. Breece, WSHFB, and T/Sgt. Chris Russell, WSSKK, are key personnel at the two MARS stations at Barksdale Air Force Base, Shreveport, La. KSAIR is Hdqts. 2nd Air Force and KSFBI is the 91st Air Base Group station. Both stations have BC 610's. KSAIR uses a long wire, KSFBI has a Johnson 10 and 20 meter rotary beam.





# Britain's finest Audio Products



## GARRARD

The world's finest automatic record changer. Competitively priced! Plays all speeds. Automatic stop. Heavier turntable. Quieter motor. Muting switch eliminates noise between records. Accurate speed. No wows, wavers, rumbles or disturbing resonance.



## LEAK "POINT ONE"

A new model of Britain's best audio amplifier. Distortion: 0.1%. Triple loop power amplifier and pre-amplifier certified by British Nat'l Physical Lab. (equiv. U. S. Nat'l Bureau of Standards) to exceed manufacturer's performance claims. Pure, undistorted musical reproduction... the ultimate in clarity and frequency response.



## WHARFEDALE

Magnificent speakers, yet inexpensive, with remarkable response. Built by Wharfedale Wireless Works under the direction of world-famous engineer, G. A. Briggs. Brilliant performance approaching living sound. Endorsed by B.B.C.



## BOOKS by G. A. BRIGGS

"Loudspeakers" and "Sound Reproduction" written by renowned authority on sound, G. A. Briggs. The only such books written expressly for the layman. A "must" for those interested in finest musical reproduction.

At your dealer or write to  
**BRITISH INDUSTRIES CORP.**  
164 Duane St., New York 13, N. Y.

outside the amateur bands for the purpose of contacting amateur stations which are operating inside the amateur bands. No traffic handling or message exchange will be permitted. All contacts logged will be acknowledged by special Armed Forces Day QSL cards.

Military stations will operate on the following frequencies: AIR (Air Force Radio Washington)—3497.5 (A-1), 7635 (A-1), 14,405 (A-3); NSS (Navy Radio Washington)—3415 (A-1), 7375 (A-1); WAR (Army Radio Washington)—6997.5 (A-1), 13,947.5 (A-1), 4020 (A-3).

-30-

## INSTRUCTORS WANTED

FROM Captain W. C. Whalin, Headquarters, Scott Air Force Base, Illinois comes word that the Base is currently recruiting civilians as Training Instructors in Communications and Radio Equipment Maintenance (GS-5 and GS-7) at \$3100 and \$3825 per annum.

Since many of the qualifications outlined in the recruitment announcement can be met by radio hams, amateurs might be interested in securing complete details from the Civilian Personnel Officer at Scott Air Force Base, Ill.

Technical qualifications include four years of experience as an instructor of organized classes in radio or electronic subjects not limited to a single phase; or four years of experience as a teacher, at the high school or comparative level, in general sciences, physics, mathematics, vocational training and/or related subjects; or four years of experience in the maintenance or repair of transmitters, receivers, or other advanced electronic equipment; or four years of experience in design, development, or research in the field of radio or electronic equipment; or any combination of the above experience aggregating four years.

For the higher rating (GS-7) one additional year of experience in the first four classifications or one additional year of graduate study in the fields of education, communications, radio or electrical engineering, physical science, mathematics, or vocational training is required.

-30-

## PHOTO CREDITS

PAGE	CREDIT
35, 36, 37, 38	Official U. S. Navy Photograph
39	Columbia Broadcasting System
40, 41, 52, 120	General Electric Company
48	Supreme Radio Co., Detroit
49, 51	Gates Radio Co.
53	RCA Laboratories
63	Station YNDG, Leon, Nicaragua
114	Barb City Industries Inc.
122	Radio Corporation of America
152	Western Union Telegraph Co.
164	Official Air Force Photo

## ON-THE-SPOT BATTERY RECORDER

**WALKIE-REGORDALL** 8 lb. miniature BATTERY RECORDER-PLAYBACK  
Continuous, permanent, accurate, indexed recording at only 5c per hr. Instantaneous, permanent playback. Picks up sound up to 60 ft. Records conferences, lectures, dictation, 2-way phone & sales talks; while walking, riding or flying. Records in closed briefcase with "hidden mike". Write for detailed literature.

**MILES REPRODUCER CO., INC.**  
812 BROADWAY Dept. ENR NEW YORK 3, N. Y.

## COAXIAL CABLE CONNECTORS



83-1AP ... \$ .30	83-1SP ... \$ .45	83-1R5 ... \$ .15
83-1P ... 1.30	83-1SPN ... .50	UG-21/U ... .67
83-1H ... .09	83-1T ... 1.30	UG-27/U ... .68
83-1J ... .80	83-22AP ... 1.10	UG-58/U ... .63
83-1R ... .40	83-168 ... .15	UG-85/U ... .88

Others in stock. Write for prices.

## AN CONNECTORS—IMMEDIATE SERVICE

Phone! Wire! Write! Your Needs.

1N34 CRYSTAL ..... 79c

### VERNIER DIAL or DRUM (from BC-221)

DIAL—2 1/2" dia. 0-100 in 360°. Black with silver marks. Has thumblock. DRUM—0-50 in 180°. Black with silver marks. .... either 85c

SELSYN 2J1G1—Brand New—400 Cyc. .... \$1.90

400 CYC. INVERTER—In. 28V 92A: Out. 115V 400 Cyc. one phase, 1.500VA, .90PF. .... \$12.50

THROAT MIKE (MT 81-A), 2 mikes in leather zipper case with 56" cord & PL68—Brand New. .... 59c

CARBON MIKE T-17, slightly used—Guaranteed—Has 5 ft. cord and PL68. .... 89c

CHOKES—30 H, 80 ma, \$1.29; 6 H, 80 ma. .... 79c

Minimum Order, \$3.00—All Orders F.O.B. Philadelphia

## RELIANCE Merchandizing Co.

2221 Arch Street • Philadelphia 3, Pa.  
Telephone: Rittenhouse 6-4927

**KAAR  
RADIOPAK**

THE MOBILE  
RADIOTELEPHONE

KAAR ENGINEERING CO.  
PALO ALTO · CALIFORNIA

## SHOOT TV TROUBLE FAST!

With H. G. CISIN'S RAPID  
"TV TROUBLE SHOOTING METHOD"

EARN more money! Locate television troubles by this quick, entirely new method. Rapid checks enable you to locate all faults in record breaking time regardless of make or model! 160 Picture, Raster, Sound trouble symptoms. Over 100 Rapid Checks including over-all alignment checks, 20 illustrations: simplified step-by-step directions!

H. G. CISIN, well-known to radio men as a recognized electronic engineer, inventor, technical author and educator, has trained thousands of television technicians, many of them now owning their own prosperous TV service organizations. The results of his years of experience are embodied in this remarkable TV TROUBLE SHOOTING METHOD.

INCREASE your earning power with the most valuable aid to TV servicing ever written! SEND YOUR NAME AND ADDRESS TODAY FOR YOUR POSTPAID COPY. only \$1.00

RUSH COUPON NOW!

H. G. CISIN, CONSULTING ENGINEER, Dept. N-2  
200 Clinton Street., Brooklyn 2, N. Y.

Enclosed is \$..... for which please rush copies (postpaid) of your TV TROUBLE SHOOTING METHOD.

Name.....

Address.....

City..... Zone..... State.....

RADIO & TELEVISION NEWS

# Classified

Rate 50c per word. Minimum 10 words

## RADIO ENGINEERING

RADIO Engineering Broadcasting, Aviation and Police Radio, Servicing, Marine Operating and Electronics taught thoroughly. Expenses low. Write for catalog. Valparaiso Technical Institute, Dept. N, Valparaiso, Ind.

PANELS for electronic, nucleonic construction projects. Complete service for designers, custom builders. Circular upon request. Gilpin Instrument Works, P. O. Box No. 8, Mt. Clemens, Mich.

## SALE

BANTAM transmitter manual. New AC, DC, CW, Phone Circuits, Antenna Dope, \$1.00. W4BIW, 751 San Antonio Drive, N.E., Atlanta 6, Ga.

PICTURE tube tester complete. Plugs into any tube tester, \$5.00. Tieman Television, 5975 Montgomery Rd., Cincinnati 13, Ohio.

KAY Megasweep, Hickok Model 620 Crosshatch Generator, G.E. SG3A R.F. Generator, Raytheon 21TR11A Mobile radio phone with 150 mc. Cab Frequency Crystals (brand new). Substantial savings. Southern Television, 2509 N. Lombardy St., Richmond, Va.

40 5BPI CATHODE Ray Tubes, Government surplus. \$2.00 each or \$70 for lot. Jordan College of Music, 1204 N. Delaware St., Indianapolis 2, Ind.

RADIO and Television Tubes. We have all numbers. They're all new at good discounts. Write us for your needs. Immediate response. Beacon Stores, Inc., Anderson Ave., Grantwood, N. J.

HOTTEST surplus list in the country. Electronics-Hydraulics, Aircraft-Gadgets. Dick Rose, Everett, Wash.

COLOSSAL bargain in radio parts. over 150 assorted radio parts including resistors, condensers, controls, coils, etc. All new, \$75.00 value, guaranteed satisfaction or money refunded, postpaid in U. S. A., \$3.00. Write for catalog. Buyers Syndicate, 30 N. Taylor St., Springfield 3, Mass.

RECORD changer parts for leading makes. We ship everywhere. Friend's Wholesale Distributors, 106 N. 6th St., Philadelphia 6, Pa.

NEW Tubes. RCA 6SN7, \$2.20; Sylvania 6AU6, \$2.00; Tel-Tone 12AU7, \$2.40; Sylvania 1B3, \$2.65; Crosley 6BG6, \$4.80. 20% discount, twelve or more tubes, 10% discount, three or more. RMA guarantee, 25% with order, balance C.O.D. Workman TV, Inc., 306 Queen Anne Road, Teaneck, N. J.

MICROPHONE Cable. One Conductor shielded, rubber covered, very flexible. \$5.00 per 100 ft. Nadborne Radio Co., 2413 Lincoln, Chicago, Ill.

HICKOK 28SX, \$119. 27TX, \$110. Brand new condition. Electronic Labs, Box 1821, Lincoln, Nebr.

53 OHM Coax; 300 ohm twin; reasonable. Inquire: Harry Van Dick, Little Falls, N. J.

DIAGRAMS Radio, Record Changers, Recorders, 75c; Television with Service Data, \$1.25 up. State manufacturer and model number. Kramer's Radio Service, Dept. N8, 36 Columbus Ave., New York 23, N. Y.

HARD-to-get and Television Tubes. Best prices. Write specific needs. 20 Mica Condensers. 98c. 20 Octal Bakelite Sockets, 98c. Add postage. Free list, no dealers. Betz, 73 Caroline Ave., Yonkers 5, N. Y.

## WANTED

AN/APR-4, other "APR," "ARR," "TS," "IE," ARC-1, ARC-3, ART-13, everything surplus; Tubes, Manuals, Laboratory equipment. Describe, price in first letter. Littell, Farhills Box 26, Dayton 9, Ohio.

## PATENT ATTORNEYS

LANCASTER Allwine & Rommel Registered Patent Attorneys. Patent practice before U.S. Patent office. Validity and infringement investigations and opinions. Booklet and form "Evidence of Conception" forwarded upon request. Suite 414, 815 15th St., N.W. Washington 5, D.C.

HERMAN Lewis Gordon. Registered Patent Attorney. Warner Building, Washington, D. C.

## CORRESPONDENCE COURSE

USED Correspondence Courses and Books sold and rented. Money back guarantee. Catalog free. (Courses bought.) Lee Mountain, Pisgah, Ala.

USED Correspondence Courses and Educational Books bought, sold, rented, catalog free. Educational Exchange, Summerville, Ga.

## MISCELLANEOUS

SPEAKERS repaired at wholesale prices, guaranteed work. Anprite Speaker Service, 70 Vesey St., New York 7, N. Y.

**Double Your Profits!**

**Sell A**

*Jensen* **needle**

**on Every Service Call**



**First Choice of:**

- Servicemen
- Phono Manufacturers
- Record Collectors

NOW AVAILABLE: Jensen Acoustic (magnetic recording) Tape

**FREE: Jensen's All-New Replacement Needle Chart**  
... 89 different needles shown in actual size. Get one from your jobber today.

Jensen makes a needle to fit any record player.

*Jensen*  
**INDUSTRIES, INC.**  
336 S. Wood St., Chicago 12, Ill.

**Let MILTON S. KIVER Help You Prepare For COLOR TV And...**

**TELEVISION SERVICING**

**Easy to TRAIN AT HOME This Practical Way!**

Men with the right training in Television Servicing are in big demand . . . pull down big pay. T.C.I. TRAINS YOU RIGHT with easy-to-follow technical training designed by servicemen, for servicemen! You learn practical, professional type Television Servicing without leaving your present job. Included are money-making extras such as set conversion, master antenna installation, COLOR TV and field servicing short cuts. You can start earning Television money after the first few lessons. You learn to test, trouble shoot and repair all types of TV sets. You learn **COLOR CONVERSION** too!

**HERE'S HOW YOU GET EXPERIENCE!**

You train on your own large screen modern television receiver, furnished as part of your course. This set is yours to keep! As an optional feature you can get two weeks of actual field experience out on service jobs and on the repair bench for Chicago's largest independent servicing organization. You learn Television Servicing by *actually doing* Television Servicing . . . you get the *practical* know-how you need to qualify for **BIG MONEY** in this fast-growing field! Age is no barrier. Many TCI students are over 40!

ACT NOW! Fill out and mail coupon for **FREE** Catalog and **SAMPLE LESSON**. Write **TODAY!**

**TELEVISION COMMUNICATIONS INSTITUTE**  
205 W. Wacker Dr., Dept. 1-J, Chicago 6, Ill.

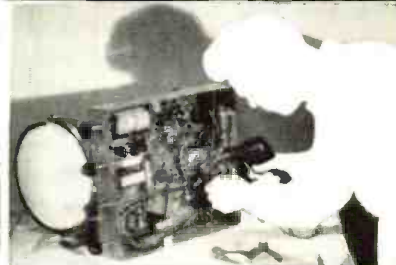

**YOU GET** and keep modern large screen Television receiver.

**YOU DO** actual testing, servicing, trouble shooting and repairing

**FOR THE BEGINNER**  
TCI offers a low-cost Pre-Television Course in Radio, especially designed to prepare you for television in just 5 to 7 weeks. Everything you need from basic radio through servicing . . . to Television.

**MAIL NOW FOR FREE BOOKLET**

MILTON S. KIVER, President  
TELEVISION COMMUNICATIONS INSTITUTE  
205 W. Wacker Dr., Dept. 1-J, Chicago 6, Ill.

O. K. Mr. Kiver! Rush **FREE** Catalog on your practical home study course in Television Servicing, including **COLOR TV**. Include **FREE** Sample Lesson. I am not obligated. Salesman will not call.

Name.....Age.....  
Address.....  
City.....Zone.....State.....  
( ) **BEGINNERS** check here for information on Pre-Tel Radio Course.

# RADIO ENGINEERING DEGREE IN 27 MONTHS

Radio engineering is a big field. There's room for you in it—if you're good. Get first-class training at Indiana Tech. Intensive specialized course. Including strong basis in mathematics and electrical engineering, advanced radio theory and design, television. Modern laboratory. Low tuition. Also 27-month courses in Aeronautical, Chemical, Civil, Electrical and Mechanical Engineering. Approved for G.I.'s. Enter June, September, December, March. You can earn part of your expenses right here in Fort Wayne while you are studying.

## INDIANA TECHNICAL COLLEGE

951 E. Washington Blvd., Fort Wayne 2, Indiana  
Please send me free information on B.S. Engineering Degree in 27 months as checked.

- Radio-Television       Aeronautical  
 Civil       Mechanical       Electrical

Name \_\_\_\_\_  
Address \_\_\_\_\_

# QUAM

## Adjust-A-Cone

### SPEAKERS

15-inch Coaxial

FIRST IN  
REPLACEMENT  
FIELD

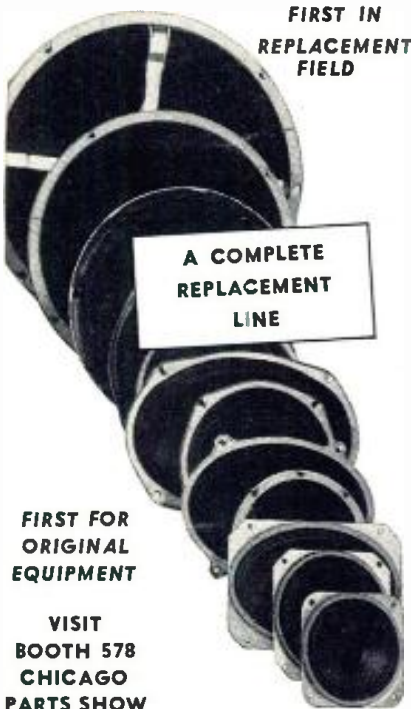

A COMPLETE  
REPLACEMENT  
LINE

FIRST FOR  
ORIGINAL  
EQUIPMENT

VISIT  
BOOTH 578  
CHICAGO  
PARTS SHOW

3-INCH

With P.M. and Dynamic Speakers from a 3" model to a 15" coaxial speaker, there isn't a radio set built today that cannot be fitted with a Quam Adjust-A-Cone Speaker. And every one is designed for the superior, trouble-free performance that means customer satisfaction and more profitable business for you.

And remember, every Quam Speaker has the exclusive U-Shaped Coil Pot that increases speaker efficiency, plus the patented Adjust-A-Cone construction that makes a rubbing voice coil as rare as a Sahara snowball.

For customer satisfaction, it pays to "Replace with Quam."

Write for Complete Quam Catalog  
Also makers of Quam Focalizer Unit  
and ION TRAPS

## QUAM-NICHOLS COMPANY

522 E. 33rd Place CHICAGO 16, ILLINOIS

MAKERS OF QUALITY SPEAKERS FOR 27 YEARS, UNDER THE SAME MANAGEMENT

# INDEX OF

# Advertisers

MAY 1951

While every precaution is taken to insure accuracy, we cannot guarantee against the possibility of an occasional change or omission in the preparation of this index.

ADVERTISER	PAGE	ADVERTISER	PAGE
Acorn Electronics Corp.	125	Mallory & Co., P. R.	Fourth Cover
Admirable TV Supply Corporation	131	Mark Electronics	102
Airex Radio Corp.	147	Master Mobile Mounts	102
Alliance Mfg. Co.	31	Mass. Radio School	102
Allied Radio Corporation	9	Metropolitan Overseas Supply	130
Alvaradio Supply Co.	150	Midwest Radio & Television Corp.	134
American Distributing Co.	157	Miles Reproducer Co., Inc.	166
American Television & Radio Co.	136	Milwaukee School of Engineering	122
Amperite, Inc.	153	Minneapolis Honeywell Regulator Company	127
Amplifier Corp. of America	154, 156	National Company, Inc.	20, 156
Arcee Electronics Co.	156	National Radio Institute	3
Arrow Sales, Incorporated	133	National Schools	11
Ashe Radio Co., Walter	95	Newark Surplus Materials Co.	134, 151
Atlas Sound Corporation	116	Newcomb Audio Products Co.	146
Baltimore Technical Institute	150	Newell Company, The	137
Barb City Industries, Inc.	86	Niagara Radio Supply Corp.	161
Barry Electronics Corp.	110	Oak Ridge Products, Inc.	132
Belle Mead Electronics	131	Oelrich Publications	119
Bell Telephone Laboratories	30	Offenbach & Reimus Company	119
Belmont Radio Corp.	15	Ohmite Mfg. Company	32
Bond Equipment Company	129	Olson Radio Warehouse	88, 89
Boyce-Roche Book Co.	154	Onan & Sons, D. W.	138
British Industries Corp.	166	Opad-Green Company	131
Brook Electronics, Inc.	142	Paramount Electronics	139
Brush Development Company	16	Peak Electronics Company	106
Buffalo Radio Supply	117	Penn Boiler & Burner Mfg. Corp.	12
C & H Sales Co.	146	Pfanstiel Chemical Co.	134
Candler System Co.	110	Phoenix Electronics, Inc.	146
Capitol Radio Engineering Inst.	87, 163	Photocon Sales	148
Central Radio & Television Schools, Inc.	153	Pickering & Company, Inc.	120
Centralab, Inc.	24, 25	Platt Electronics Corp.	112
Channel Master Corp.	79	Poly-Tech	128
Chelsea Television Center, Inc.	139	Prenax Products	118
Chicago Industrial Instrument Co.	106	Premier Radio Tube Co.	97
Chicago Transformer Company	115	Progressive Electronics Company	120
Cisin, H. C.	166	Pyramid Electric Company	26
Cleveland Institute of Radio Electronics	18	Quam-Nichols Company	168
Clear Beam Television Antennas	100	RCA Institutes, Inc.	102
Columbia Electronic Sales	114	Radio Apparatus Corp.	115
Comet Electronic Sales Co.	121	Radio City Products Co.	152
Communications Equipment Company	101	Radio Corporation of America	77, Second Cover
Concord Radio Corporation	124	Radio Craftsmen, Inc., The	90
Cornell Dubilier Electric Corp.	129, 162	Radio Development & Sales Co.	162
Coyne Electrical & Television-Radio School	80, 157	Radio Distributing Co.	80
Crest Television Labs	133	Radio Ham Shack, Inc.	105
D & H Distributing	150	Radio Parts Company	85
De Forest-Sanabria Corp.	7	Radio Receptor Co., Inc.	127, 48
DeForest's Training, Inc.	5	Rauland Corporation, The	48
Dumont Laboratories, Allen B.	Third Cover	Raytheon Mfg. Co.	22
East Coast Electronics	124	Red Arrow Sales Co.	151
Editors & Engineers, Ltd.	113	Reeves Saundcraft Corp.	126
Eddie Electronics, Inc.	142	Regency	80
Electro Devices	114	Rek-O-Kul Co., Inc.	128
Electronic Expeditors, Inc.	76	Reliance Merchandizing Co.	166
Electronic Indicator Corporation	128	Rider Publishers, Inc., John F.	107
Electronics Institute, Inc.	158	Rinehart Books, Inc.	148
Electronic Instrument Co., Inc.	34	Rose Company, The	163
Electronic Technical Institute	140	Sam's Surplus	110
Electro-Technical Industries	162	Sams & Company, Howard W.	84, 98
Electro Voice, Inc.	159	Sarkes-Tarzen, Inc.	28
Eric Resistor Corporation	108	Schott Company, Walter L.	113
Espey Mfg. Company, Inc.	127	Science Kits, Ltd.	78
Fair Radio Sales	123	Sheldon Electric Company	10
Federal Electronics Institute	139	Simpson Electric Co.	29
Feller Engineering Co.	158	Snyder Manufacturing Company	118
Fisher Radio Corp.	116	Sobling Products Co., Inc.	113
Franklin Technical Institute	129	Sprague Products Co.	14
G. L. Electronics	138	Standard Surplus	109
General Electric Company	13, 33, 71	Standard Transformer Corp.	135
General Electronic Distributing	92, 93	Star Electronics Distrib., Inc.	131
General Test Equipment	129	Steve-El Electronics	155
Goodheart, R. E.	130	Sun Radio of Washington, D. C.	150
Gonset Company	141	Supreme Publications	91
Greenlee Tool Co.	120	Sylvania Electric Products, Inc.	19
Greylock Electronic Supply Co.	165	TAB	169, 170
Grossman, David	158	Technical Radio Parts Co.	137
Hallierafter Company, The	17	Telex	162
Harrison Radio	100	Television Communications Inst.	167
Harvard Laboratory	147	Tetrex, Inc.	141
Harvey Radio Company, Inc.	161	Thomas Electronics, Inc.	149
Heath Company	72, 73, 74, 75	Trad Television Corp.	160
Henry Radio Stores	160	Transvision, Inc.	102
Hy-Grade Electronics, Inc.	141	Triad Transformer Mfg. Co.	158
Hatron Radio & Electronics Corp.	27	Triplett Electrical Instrument Co.	21
Indiana Technical College	168	Trio Manufacturing Co.	143
Instructograph Co.	119	Tri-State College	131
Insuline Corp. of America	96	Tung-Sol Lamp Works	94
J & H Television Co.	151	Turner Company	145
J F D Mfg. Co., Inc.	103, 121, 138	Ungar Electric Tool Co., Inc.	113
J S H Sales Company	118	Upstate Distributors	130
Jensen Industries	167	V & H Radio & Electronics Supply	78
Jensen Mfg. Co.	104	Valparaiso Technical Institute	137
Jersey Specialty Company, Inc.	135	Variety Electric Company	118
KAAR Engineering Company	166	Veri-Best Electronics Co.	151
Kester Solder Co.	142	Waldom Electronics, Inc.	155
La-Pointe Plasmacoid Corporation	23, 132	Weller Electric Corp.	8
Leotone Radio Company	156	Wells Sales, Inc.	81
Lormel Products Company, The	140	West Region Electronics	113
Loris Sales	139	Wholesale Radio Parts Co., Inc.	132
Lowell Metal Products Corp.	110	Wind Turbine Co.	108
McCormell's	150	Workshop Associates, Inc.	99
Medies Radio Company	82, 83	World Radio Laboratories, Inc.	137
Macmillan Company	111	World Wide Packing & Shipping Co.	154
Magnafilter Corporation	96	YMCA Trade & Tech. School	130







# 215

SQUARE INCHES OF FINEST  
PICTORIAL REPRODUCTION...

*Yours with the*

*new Bent-Gun for  
edge-to-edge sharpness,  
gray filter face plate,  
"Standard" neck length of 7 $\frac{1}{16}$ "*

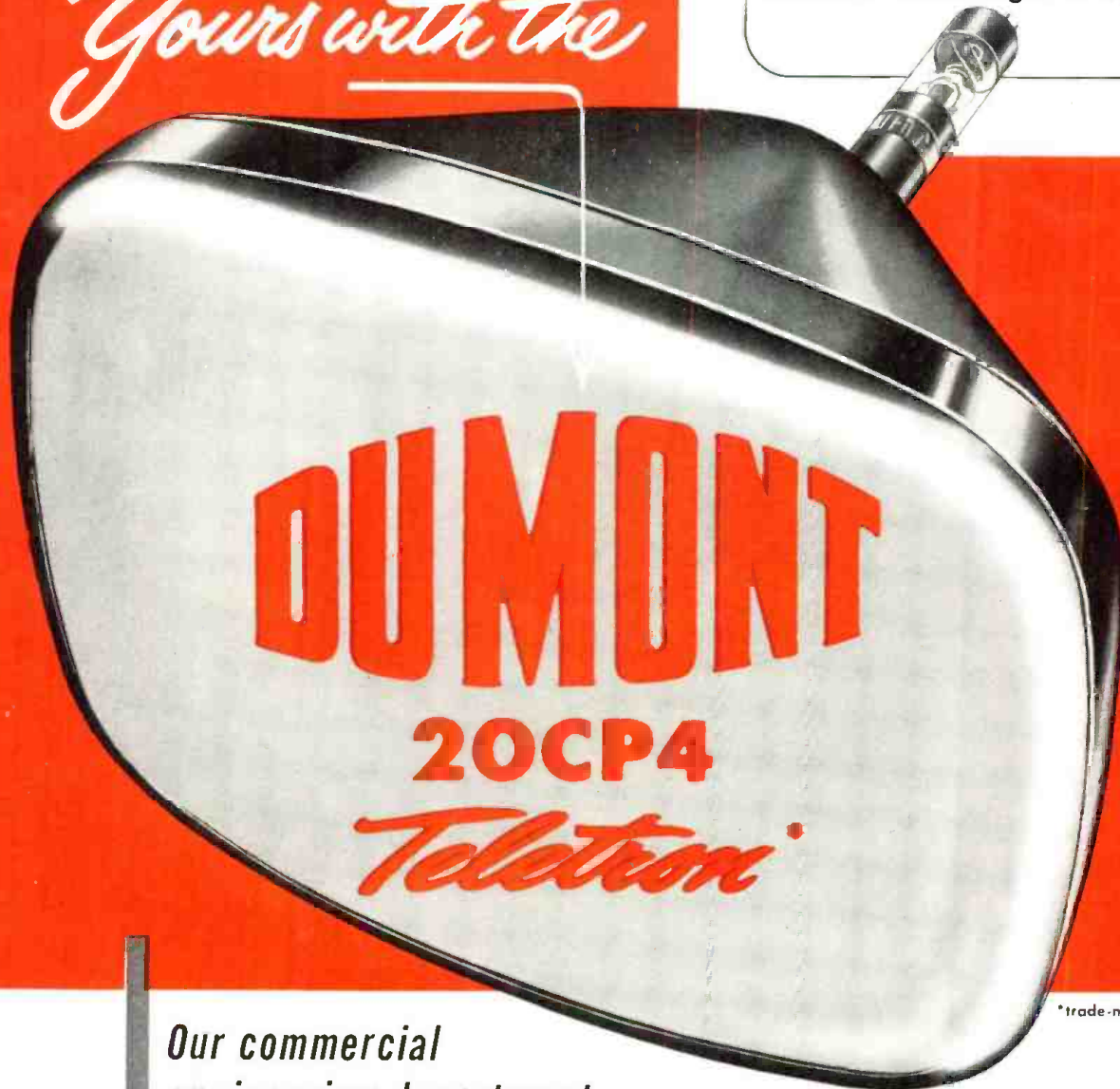

\*trade-mark

*Our commercial  
engineering department  
invites all design inquiries*

ALLEN B. DU MONT LABORATORIES INC., TUBE DIVISION, CLIFTON, N. J.

# In Volume Controls, too ...

## fast, sure fit

## is important

In a survey of hundreds of servicemen, the importance of fast, sure installation was emphasized time after time in connection with volume controls. If you want a control that lets you do the job fast . . . and do it right . . .



# Make Sure! Make it Mallory!

When you use the Mallory Midgetrol\*, you get a combination of features that can't be matched.

*First*, you get a permanently fixed, tubular brass shaft that can be adapted for split-knurl or flatted type knobs in a few seconds by inserting one of the steel shaft ends supplied in every package. This means utmost convenience without sacrificing the stability of permanent, two-point shaft suspension.

*Second*, you get the convenience of AC switch design that permits secure attachment, *without*

*removing the control housing.* Positive indexing assures proper position.

*Third*, you get exceptionally accurate resistance values and taper curves.

*Fourth*, you can be sure of years of quiet, satisfactory service life through extremes of humidity and temperature

Make it Mallory and make sure! Ask your distributor to show you the time-proved Mallory Midgetrol with the new features that make installation faster and simpler than ever.



Dual concentric Mallory Midgetrols can be made up easily by combining factory-assembled front and rear sections of desired resistance values. Ask your Mallory Distributor for details!

*Depend on your Mallory Distributor for precision quality at competitive prices*

P. R. MALLORY & CO. Inc.

# MALLORY

CAPACITORS • CONTROLS • VIBRATORS • SWITCHES • RESISTORS  
• RECTIFIERS • VIBRAPACK\* POWER SUPPLIES • FILTERS  
\*Reg. U.S. Pat. Off.

APPROVED PRECISION PRODUCTS

P. R. MALLORY & CO., Inc., INDIANAPOLIS 6, INDIANA

\*Reg. U. S. Pat. Off.